

Sect.	Type	Room	Instructor	Hrs.	Units	Days	Begin-End	Footnotes	Sect.	Type	Room	Instructor	Hrs.	Units	Days	Begin-End	Footnotes
-------	------	------	------------	------	-------	------	-----------	-----------	-------	------	------	------------	------	-------	------	-----------	-----------

# SPRING 2006 CLASSES



## New Spring Classes

AJ 6	Introduction to Conflict Resolution
AJ 176	Criminal Street Gangs
CMUN 11	Business Communication
CSIS 132	Intermediate Word Processing - MS Word
DM 61	3D Animation II
JPN 1B	Elementary Japanese
MATH 299C	Math for Science
MUS 28	Jazz/Pop Piano
PE 13A	Fundamentals of Volleyball
POLS 6	Introduction to Conflict Resolution
PSCI 2	Introduction to Meteorology
PSYC 6	Introduction to Conflict Resolution
RE 162	Real Estate Practice
SSCI 270B	Introduction to the Social Sciences
THEA 20	Introduction to Scriptwriting

New Noncredit Classes - see page 108

### For listings of:

- ◆ Courses with additional fees. . . . . page 6
- ◆ Hollister classes . . . . . pages 98-99
- ◆ Late Afternoon/Evening courses. . . . . page 102
- ◆ Late-Start/Short-term courses . . . . . page 103
- ◆ Morgan Hill classes. . . . . pages 100-101
- ◆ Noncredit . . . . . page 108
- ◆ Online courses . . . . . page 37
- ◆ Summer Session . . . . . page 104
- ◆ Telecourses (Gavilan). . . . . page 38
- ◆ Telecourses (San Jose State University) . . . . . page 38
- ◆ Tues-Thurs/Mon-Wed Classes. . . . . pages 32-35
- ◆ Transfer Institute. . . . . page 25
- ◆ Weekend courses. . . . . page 102
- ◆ Winter Intersession. . . . . pages 39-41



## QuickBooks Pro

### Business Accounting Software

#### ACCT/CSIS 120 - Computerized Accounting

Content includes general ledger, sales journal, cash receipts journal, cash payments journal, purchases journal, payroll, receivables, payables and related financial reports.

Sect. 6005 MHG5 Barta M Thursday 6:30-9:20 pm

## ACCOUNTING

### ACCT 20 Financial Accounting

**Advisory:** Eligible for English 250, English 260 and Mathematics 233.

**Transferable:** CSU; UC; CAN: BUS 2, BUS SEQ. A

An introduction to accounting principles and concepts. The course includes the application of accounting theory to accumulate and summarize financial data. This course has the option of a letter grade or credit/no credit.

4001	LEC	BU118	WOLOWITZ J	4.00	4.0	MW	1235P-0225P
6001	LEC	BU118	STAFF	4.00	4.0	W	0600P-0950P

### ACCT 21 Managerial Accounting

**Advisory:** Accounting 20.

**Transferable:** CSU; UC; CAN: BUS 4, BUS SEQ. A

This course covers the internal uses of accounting information for managerial decision making. Includes coverage of managerial control, cost-volume-profit relationships, budgeting, cost accounting, and other related topics. This course has the option of a letter grade or credit/no credit.

4002	LEC	BU118	WOLOWITZ J	4.00	4.0	MW	0910A-1100A
6002	LEC	SS203	STAFF	4.00	4.0	Tu	0600P-0950P

### ACCT 23 Independent Study

**Required:** The study outline prepared by the student and the instructor must be filed with the department and the dean.

**Transferable:** CSU

Designed to afford selected students specialized opportunities for exploring areas at the independent study level. The courses may involve extensive library work, research in the community, or special projects. May be repeated until six units of credit are accrued. This course has the option of a letter grade or credit/no credit.

4003	IND	BU129	WOLOWITZ J	3.00	1.0	DHR	0000-0000
------	-----	-------	------------	------	-----	-----	-----------

### ACCT 103 General Office Accounting

**Advisory:** Eligible for Mathematics 205.

**Transferable:** CSU

This course is designed to prepare students for entry-level office accounting positions. Emphasis is on practical accounting applications. This course has the option of a letter grade or credit/no credit.

6003	L/L	MHG4	BARTA M	3.00	2.0	M	0630P-0920P	96
<b>Above class meets at Morgan Hill Community site</b>								

### ACCT 105 Payroll Accounting

**Advisory:** Eligible for Mathematics 205, completion of Accounting 101.

**Transferable:** CSU

An introduction to the calculating, journalizing, paying and reporting of employee earnings, employee withholding and employer payroll tax expenses. The course emphasizes procedures which conform to federal and state legal requirements. This course has the option of a letter grade or credit/no credit.

6004	LEC	HOL6	STAFF	2.00	2.0	Th	0630P-0820P	96
<b>Above class meets at the Hollister Briggs site</b>								

### ACCT 120 Computerized Accounting - QuickBooks

**Advisory:** CSIS 1 or CSIS 2 or the equivalent computer experience. ACCT 20 or ACCT 101 or ACCT 103 or ACCT 105 or the equivalent accounting experience.

**Transferable:** CSU

An introduction to computer-assisted accounting. Hands-on use of a microcomputer menu-driven accounting package to do general ledger, sales journal, cash receipts journal, cash payments journal, purchases journal, payroll, receivables, payables and related financial reports. This course has the option of a letter grade or credit/no credit. Repeatable whenever a new software package is adopted. This course is also listed as CSIS 120.

6005	L/L	MHG5	BARTA M	4.00	2.0	Th&1	0630P-0920P	25 35 96
<b>Above class meets at Morgan Hill Community site</b>								

Sect. Type Room Instructor Hrs. Units Days Begin-End Footnotes

**ACCT 190 Occupational Work Experience/ Accounting**

**Required:** Declared vocational major. Concurrent enrollment in seven or more units (including CWE units, except for summer school. For summer school, enrollment in one other class is required). Minimum 2.00 G.P.A.

**Transferable:** CSU

College credit for learning experience obtained on the job in accordance with a training plan developed cooperatively between the employer, college and student. 75 hours per semester per unit or 60 hours per semester for unpaid experience. This is a credit/no credit course. May be taken for a maximum of 16 work experience units.

4004	WEX	SC154S	KERRL	5.00	1.0	DHR	0000-0000	16
4005	WEX	SC154S	KERRL	10.00	2.0	DHR	0000-0000	16
4006	WEX	SC154S	KERRL	15.00	3.0	DHR	0000-0000	16
4007	WEX	SC154S	KERRL	20.00	4.0	DHR	0000-0000	16

**Acting: See Theatre Arts**

**ADMINISTRATION OF JUSTICE****AJ 6 Introduction to Conflict Resolution**

**Advisory:** English 250 and English 260.

**Transferable:** CSU; CSU-GE: D7; GAV-GE: D2

Introduction to Conflict Resolution introduces students to conflict resolution and mediation. Integrating theory and practice, students will assess core concepts about the causes and resolution of conflict, and will practice communication skills for conflict resolution. Students will examine how ethnicity, gender, and class affect power in conflict situations. They will be able to formulate appropriate conflict resolution strategies, and will develop and practice various basic co-mediation skills. This course has the option of a letter grade or credit/no credit. This course is also listed as POLS 6 and PSYC 6.

4757	LEC	SS216	HALPERL	3.00	3.0	TuTh	0945A-1100A	
------	-----	-------	---------	------	-----	------	-------------	--

**AJ 10 Introduction to the Administration of Justice**

**Advisory:** Eligible for English 250 and English 260.

**Transferable:** CSU; UC; CAN: AJ 2

The history and philosophy of justice as it evolved throughout the world; in-depth study of the American system and various sub-systems; roles and role expectations of criminal justice agents in their interrelationships in society; concepts of crime causations, punishments and rehabilitation; ethics, education and training for professionalism in the social system.

4057	LEC	BU118	SMITH S	3.00	3.0	MW	1110A-1225P	
4058	LEC	BU118	SMITH S	3.00	3.0	TuTh	1245P-0200P	

**AJ 12 Criminal Procedures**

**Advisory:** Eligible for English 250 and English 260.

**Transferable:** CSU

Legal processes from pre-arrest, arrest through trial, sentencing and correctional procedures; a review of the history of case and common law; conceptual interpretations of law as reflected in court decisions; a study of case law methodology and case research as the decisions impact upon the procedures of the justice system.

4059	LEC	BU120	SMITH S	3.00	3.0	MW	0810A-0925A	
------	-----	-------	---------	------	-----	----	-------------	--

**AJ 14 Criminal Law**

**Advisory:** Eligible for English 250 and English 260.

**Transferable:** CSU; UC; CAN: AJ 4

Historical development, philosophy of law and constitutional provisions; definitions, classifications of crime, and their applications to the system of administration of justice; legal research, review of case law, methodology, and concepts of law as a social force. Explores crimes against persons, property, and the state.

4060	LEC	BU118	SMITH S	3.00	3.0	W	0300P-0550P	
------	-----	-------	---------	------	-----	---	-------------	--

**For on-campus child care**

contact the Child Development Center at (408) 848-4815

Sect. Type Room Instructor Hrs. Units Days Begin-End Footnotes

**South Bay Regional Public Safety Training Consortium**

Gavilan College has been providing quality Administration of Justice education and training for over 35 years. So, when you want to begin your career in Law Enforcement you can go to the same place where thousands of Northern California law enforcement officers got their start.

**Careers in**

Law Enforcement Fire Technology  
Probation Officer Dispatcher  
Corrections Officer Juvenile Hall Counselor

[www.gavilan.edu/aj](http://www.gavilan.edu/aj)



Gavilan College is a member of the South Bay Regional Public Safety Training Consortium. This consortium is funded by all colleges regionally to provide vocational specific training which may require special facilities, special training conditions or is presented outside of schedules of regular college classes. For more information, call (408) 270-6458.

**Certificate of Achievement****COMPUTERIZED ACCOUNTING****16 units**

Learn Computerized bookkeeping skills for a modern office.

**CalWORKs**

California Work Opportunity and Responsibility to Kids Program

Become self-sufficient through education, employment and supportive services!

The Gavilan College CalWORKs program, located in LI 101A (in the EOPS/CalWORKs Department) provides support to students who receive public assistance.

To find out what services are available call 408-848-4813 or 408-848-4740 or stop by to see us.

Sect.	Type	Room	Instructor	Hrs.	Units	Days	Begin-End	Footnotes
-------	------	------	------------	------	-------	------	-----------	-----------

### AJ 16 Introduction to Evidence

**Advisory:** Eligible for English 250 and English 260.

**Transferable:** CSU

Origin, development, philosophy and constitutional basis of evidence; constitutional and procedural considerations affecting arrest, search and seizure; kinds and degrees of evidence and rules governing admissibility; judicial decisions interpreting individual rights and case studies viewed from a conceptual level.

4061	LEC	BU118	SMITH S	3.00	3.0	TuTh	0945A-1100A	
------	-----	-------	---------	------	-----	------	-------------	--

### AJ 18 Community and Human Relations

**Advisory:** Eligible for English 250 and English 260.

**Transferable:** CSU; UC

The relationship of criminal justice agents and the community; causal and symptomatic aspects of community understanding; lack of cooperation and mistrust; study of behavioral causes; ways to develop and maintain amicable relationships.

6008	LEC	MHG3	JONES W	3.00	3.0	M	0630P-0920P	
------	-----	------	---------	------	-----	---	-------------	--

Above class meets at Morgan Hill Community site

### AJ 19 Introduction to Investigation

**Advisory:** Eligible for English 250 and English 260.

**Transferable:** CSU

Fundamentals of investigation; techniques of crime scene search and recording; collection and preservation of physical evidence; modus operandi processes; sources of information; interview and interrogation, and follow-up investigation.

6009	LEC	MHG13	JONES W	3.00	3.0	W	0630P-0920P	
------	-----	-------	---------	------	-----	---	-------------	--

Above class meets at Morgan Hill Community site

### AJ 24 Administration of Justice Interviewing & Report Writing

**Advisory:** Eligible for English 250 and English 260.

**Transferable:** CSU

General course using various methods to develop students' abilities in note taking, interviewing, information gathering, report writing mechanics and organization and critical evaluation. Students will interview individuals and will write and analyze police reports to meet the standards of the Criminal Justice System.

4062	ONLINE	HOWELL J		3.00	3.0	DHR	0000-0000	38
------	--------	----------	--	------	-----	-----	-----------	----

**This online class will be delivered entirely over the internet. After enrolling, start the class by going to <http://www.gavilan.edu/disted/>, click on your class link, and email the instructor at [jhowell@gavilan.edu](mailto:jhowell@gavilan.edu). Students who have not begun the class or contacted the instructor by 5 pm on January 26 will be dropped from the class.**



### AJ 176 Criminal Street Gangs

**Advisory:** Eligible for English 250 and English 260.

**Transferable:** CSU

This course is designed to explore historical developments, origins, philosophy and current trends and activities in criminal street gangs within California; explore areas of violence, recruitment, drug use, graffiti and attire; emphasis placed on organization within gangs and racial backgrounds including types of solutions in the criminal justice system use to combat street gangs.

6010	LEC	SS210	PULIDO D	3.00	3.0	Tu	0630P-0920P	20
------	-----	-------	----------	------	-----	----	-------------	----

### AJ 190 Occupational Work Experience/ Administration of Justice

**Required:** Declared vocational major. Concurrent enrollment in seven or more units (including CWE units, except for summer school. For summer school, enrollment in one other class is required). Minimum 2.00 G.P.A.

**Transferable:** CSU

College credit for learning experience obtained on the job in accordance with a training plan developed cooperatively between the employer, college and student. 75 hours per semester per unit or 60 hours per semester for unpaid experience. This is a credit/no credit course. May be taken for a maximum of 16 work experience units.

4063	WEX	SC154S	KERRL	5.00	1.0	DHR	0000-0000	
4064	WEX	SC154S	KERRL	15.00	3.0	DHR	0000-0000	
4065	WEX	SC154S	KERRL	10.00	2.0	DHR	0000-0000	
4066	WEX	SC154S	KERRL	20.00	4.0	DHR	0000-0000	

Sect.	Type	Room	Instructor	Hrs.	Units	Days	Begin-End	Footnotes
-------	------	------	------------	------	-------	------	-----------	-----------

## ALLIED HEALTH

### AH 3 The Person in the Life Cycle

**Prerequisite:** Eligible for English 250 and English 260.

**Transferable:** CSU; UC; CSU-GE: E2; GAV-GE: E2, F

Interaction of social, emotional, intellectual, and physical attributes related to the development and realization of human potential across the life span.

4028	LEC	LS104	LOGAN C	3.00	3.0	Th	0110P-0400P	
------	-----	-------	---------	------	-----	----	-------------	--

4029	LEC	LS104	DUFRESNE	3.00	3.0	Th	0410P-0700P	
------	-----	-------	----------	------	-----	----	-------------	--

4030	ONLINE	BEDELL K		3.00	3.0	DHR	0000-0000	38
------	--------	----------	--	------	-----	-----	-----------	----

**This online class will be delivered entirely over the internet. After enrolling, start the class by going to <http://www.gavilan.edu/disted/>, click on your class link, and email the instructor at [kbedell@gavilan.edu](mailto:kbedell@gavilan.edu). Students who have not begun the class or contacted the instructor by 5 pm on January 26 will be dropped from the class.**



### AH 11 Nutrition

**Prerequisite:** Eligible for English 250 and English 260.

**Advisory:** Chemistry 30A and Mathematics 205.

**Transferable:** CSU; UC; CSU-GE: E2; GAV-GE: E2, F; CAN: FCS 2

This course is designed to meet the needs of the Allied Health student and the general education student alike. The major aim of this course is to help the student acquire relevant information about nutrition which they can use professionally and/or personally. The course will cover the practical aspects of normal nutrition, ways to promote sound eating habits throughout the life cycle, and physiological contribution nutrients make to body structure and function. This course is also listed as BIO 11.

4031	LEC	LS104	AKROP M	3.00	3.0	Tu	0110P-0400P	25
------	-----	-------	---------	------	-----	----	-------------	----

4032	LEC	LS104	AKROP M	3.00	3.0	Tu	0410P-0700P	25
------	-----	-------	---------	------	-----	----	-------------	----

4033	ONLINE	AKROP M		3.00	3.0	DHR	0000-0000	25 38
------	--------	---------	--	------	-----	-----	-----------	-------

**This online class will be delivered entirely over the internet. After enrolling, start the class by going to <http://www.gavilan.edu/disted/>, click on your class link, and email the instructor at [makrop@gavilan.edu](mailto:makrop@gavilan.edu). Students who have not begun the class or contacted the instructor by 5 pm on January 26 will be dropped from the class.**



### AH 16 Intravenous Therapy/Blood Withdrawal

**Prerequisite:** Successful completion of Allied Health 64, Allied Health 44, (with a grade of C or better) or equivalent.

**Transferable:** CSU

Theoretical applications and clinical experience to safely administer intravenous therapy. Principles and practices in intravenous therapy. (Approved by the Board of Vocational Nursing for certification in IV Therapy and Blood Withdrawal.) Approved for 36 hours of continuing education credit. (BRN #00892)

4034	LEC	HOB114	STUBBLEFIELD	2.00	2.0	MTuWTh	0900A-0330P	11 93
------	-----	--------	--------------	------	-----	--------	-------------	-------

06/06/06 - 06/15/06

### AH 23 Independent Study

**Required:** The study outline prepared by the student and the instructor must be filed with the department and the dean.

**Transferable:** CSU

Designed to afford selected students specialized opportunities for exploring areas at the independent study level. The courses may involve extensive library work, research in the community, or special projects. May be repeated until six units of credit are accrued. This course has the option of a letter grade or credit/no credit.

4035	IND	HOB104	BEDELL K	3.00	1.0	DHR	0000-0000	22
------	-----	--------	----------	------	-----	-----	-----------	----

### AH 30 Standard First Aid and Cardiopulmonary Resuscitation

**Transferable:** CSU; UC; GAV-GE: E2

First aid training to prepare people to meet the needs of emergencies when medical assistance is delayed. Incorporates the techniques of cardiopulmonary resuscitation. Includes information on the care of wounds, fractures, burns, poisoning, shock, as well as elementary rescue transportation. A satisfactory grade qualifies the student for a Red Cross Standard First Aid card and the Red Cross CPR card. May be repeated three times for credit.

4036	LEC	LS104	LOGAN C	2.00	2.0	MW	1110A-1200P	
------	-----	-------	---------	------	-----	----	-------------	--

Sect. Type Room Instructor Hrs. Units Days Begin-End Footnotes

**AH 32 Basic Cardiac Life Support****Transferable:** CSU

Course designed to teach students skills in adult, child and infant cardiopulmonary resuscitation. Specifically designed for health professionals. Successful completion will result in certification by the American Heart Association or American Red Cross. This is a credit/no credit course. May be repeated up to three times for credit.

6006	LEC	HOB114	LOGAN C	18.00	1.0	SAT/SUN	0800A-0500P	11 32
02/11/06 - 02/12/06								
6007	LEC	HOB114	LOGAN C	18.00	1.0	SAT/SUN	0800A-0500P	11 32
03/04/06 - 03/05/06								

**AH 44 Compensatory Nursing Practice****Prerequisite:** Successful completion of Allied Health 43 and an active valid, unrestricted California LVN license.**Transferable:** CSU

Concepts and principles of the nursing process applied to preventive, remedial, supportive, rehabilitative, and teaching aspects in meeting the health needs of the patient requiring compensatory nursing interventions. Incorporates nursing concepts and experiences with all age groups, including senior adults.

4038	L/L	HOB102	TURNER S BEDELL K TURNER S BEDELL K	19.00	10.0	WTh  MTu	1010A-0100P  0210P-1000P	93
------	-----	--------	--	-------	------	----------------	--------------------------------	----

**AH 62 Medical-Surgical Nursing****Prerequisite:** Successful completion of Allied Health 61 with a grade of C or better or equivalent. Equivalency determined by written and performance exams.**Transferable:** CSU

Course is designed to provide both theoretical and clinical experience in the care of adult, medical-surgical clients. This course will further refine basic nursing skills and introduce more complicated nursing situations. Content includes pre-operative and post-operative care of the client with pain, cancer, and care of the client with disorders of the musculoskeletal, integumentary, gastrointestinal, and respiratory systems. Related pharmacology is included.

4039	L/L	HOB102	STUBBLEFIELD BEDELL K STUBBLEFIELD BEDELL K	21.00	11.0	WTh  MTu	0710A-1000A  0630A-0200P	93
------	-----	--------	--	-------	------	----------------	--------------------------------	----

**AH 64 Medical-Surgical/Pediatric Nursing****Prerequisite:** Successful completion of AH 61, 62, and 63 with a grade of C or better or equivalent. Equivalency determined by written and performance exams.**Transferable:** CSU

Course contains two components to provide theoretical and clinical experience in medical surgical and pediatric nursing. Content includes care of clients with disorders of the endocrine and neurosensory systems, mental illness, emergency nursing and care of the child, including preventive measures and health teaching. A leadership component is included to prepare the student for the realistic work assignment of the licensed vocational nurse. Related pharmacology is included.

4040	L/L	HOB102	AMAROD BEDELL K AMAROD BEDELL K	21.00	11.0	WTh  MTu	0110P-0400P  0630A-0200P 0200P-0930P	93
------	-----	--------	--	-------	------	----------------	---	----

**AH 140 Information Competency for Health Professionals****Transferable:** CSU

A beginning course on how to find reliable, current health-related information, using the Internet and other electronic resources. Approved for 18 hours of continuing education credit (BRN Provider #00892.) This course is also listed as LIB 140.

4041	ONLINE	MEADER S		3.00	1.0	DHR	0000-0000	11 25 38
03/06/06-04/13/06 <b>This online class will be delivered entirely over the internet. After enrolling, start the class by going to <a href="http://www.gavilan.edu/disted/">http://www.gavilan.edu/disted/</a>, click on your class link, and email the instructor at <a href="mailto:smeader@gavilan.edu">smeader@gavilan.edu</a>. Students who have not begun the class or contacted the instructor by 5 pm on March 11 will be dropped from the class.</b>								



Sect. Type Room Instructor Hrs. Units Days Begin-End Footnotes



# Tutoring Center

Room - LI 116 408-848-4838



**Free tutoring is available in a variety of subjects.**

**Work with a peer tutor and fellow students to develop a better understanding of course content.**

**Fall/Spring Semester:**

Mon. - Thurs.: 8:00 a.m. - 7:45 p.m.  
Fri.: 8:00 a.m. - 4:00 p.m.

**Summer Session:**

Call for hours

Debbie Roderick, Tutoring Program Coordinator  
Mashael Brown, Evening Program Specialist

## Gavilan College Allied Health Careers!

- Clinical Medical Assisting
- Nursing Assistant
- Home Health Aide
- Licensed Vocational Nurse
- Registered Nurse

For information call the Allied Health Department  
408-848-4883

**UPDATED CLASS****CSIS 124 - Windows Fundamentals**

Now using Microsoft Windows<sup>XP</sup>

This class is repeatable.



Sect.	Type	Room	Instructor	Hrs.	Units	Days	Begin-End	Footnotes
<b>AH 171</b>	<b>Advanced Clinical Medical Assisting</b>							
<b>Prerequisite:</b> AH 170 with a grade of C or better or equivalent. Equivalency determined by written and performance exams.								
<b>Transferable:</b> CSU								
Course provides instruction and clinical experience in advanced concepts of clinical medical assisting including specialty procedures and treatments.								
4042	L/L	HOB114	STAFF	10.00	6.0	MTuWTh	0100P-0330P	96

### AH 180 Fundamentals of Nursing--Convalescent

**Prerequisite:** Eligible for English 250 and English 260. Clearance from the Department of Health Services (Form HS283), fingerprint card, and health clearance required prior to clinical placement.  
**Transferable:** CSU

A course to provide a basic introduction to patient care in the convalescent setting. Emphasizes principles, understanding and skills necessary to perform basic nursing procedures safely and effectively. Includes introduction to health care, planning, safety, infection control, personal care, basic procedures, rehabilitation, nutrition and clients' rights and needs. At the completion of this course students will qualify for state certification as a nursing assistant.

4043	L/L	HOB114	MACHADO M MACHADO M	12.00	8.0	MTu W	0900A-1200P 0630A-0130P	92 94 96
4044	L/L	HOB114	MACHADO M MACHADO M	12.00	8.0	MTu Th	0900A-1200P 0630A-0130P	92 94 96
4045	L/L	HOB114	MACHADO M MACHADO M	12.00	8.0	MTu F	0900A-1200P 0630A-0130P	92 94 96

### AH 190 Occupational Work Experience/Allied Health

**Required:** Declared vocational major. Concurrent enrollment in seven or more units (including CWE units, except for summer school. For summer school, enrollment in one other class is required). Minimum 2.00 G.P.A.

**Transferable:** CSU

College credit for learning experience obtained on the job in accordance with a training plan developed cooperatively between the employer, college and student. 75 hours per semester per unit or 60 hours per semester for unpaid experience. This is a credit/no credit course. May be taken for a maximum of 16 work experience units.

4046	WEX	HOB114	BEDELL K	5.00	1.0	TBA	0000-0000	76
4047	WEX	HOB114	BEDELL K	10.00	2.0	TBA	0000-0000	76
4048	WEX	HOB114	BEDELL K	15.00	3.0	TBA	0000-0000	76
4049	WEX	HOB114	BEDELL K	20.00	4.0	TBA	0000-0000	76

## Anatomy: See Biological Sciences

## ANTHROPOLOGY

### ANTH 1 Introduction to Physical Anthropology

**Advisory:** English 250, English 260 and Mathematics 205.

**Transferable:** CSU; UC; CSU-GE: B2; IGETC: 5B; GAV-GE: B2; CAN: ANTH 2

Survey study of human biological, social and cultural development over the last several million years. The implications of evolutionary theory for the world today are also considered. Principal topics are evolutionary theory, Mendelian and molecular genetics, the fossil record, primatology, the nature of human diversity "race", and the question of continuing evolution.

4074	LEC	SS210	KLEIN D	3.00	3.0	MW	0945A-1100A	
4755	ONLINE	KLEIN D		3.00	3.0	DHR	0000-0000	38

**This online class will be delivered entirely over the internet. After enrolling, start the class by going to <http://www.gavilan.edu/disted/>, click on your class link, and email the instructor at [dklein@gavilan.edu](mailto:dklein@gavilan.edu). Students who have not begun the class or contacted the instructor by 5 pm on January 26 will be dropped from the class.**

### ANTH 3 Introduction to Cultural Anthropology

**Advisory:** Eligible for English 250 and English 260.

**Transferable:** CSU; UC; CSU-GE: D1; IGETC: 4A; GAV-GE: D2, F; CAN: ANTH 4

The comparative study of human societies and cultures. Emphasis is placed on the analysis of small scale non-western societies. Specific topics include the nature of culture, the enculturation process, kinship systems and the cross-cultural analysis of religious, political and economic institutions. Culture change and the relevance of anthropology for understanding the modern world are also considered.

4075	LEC	SS205	KLEIN D	3.00	3.0	TuTh	1110A-1225P	
4076	LEC	MHG13	KLEIN D	3.00	3.0	MW	1200P-0115P	

**Above class meets at Morgan Hill Community site**

Sect.	Type	Room	Instructor	Hrs.	Units	Days	Begin-End	Footnotes
<b>ANTH 5</b>	<b>Magic, Witchcraft and Religion</b>							
<b>Advisory:</b> English 250 and English 260.								
<b>Transferable:</b> CSU; UC; CSU-GE: D1; IGETC: 4A; GAV-GE: D2								
Cross cultural study of beliefs and practices with respect to the supernatural, health/wellness and healing, myth, ritual, witchcraft, magic, symbolism, altered states of consciousness, and revitalization. Also connection and reflection of cultural contexts in which they are found.								
4077	LEC	SS111	KLEIN D	3.00	3.0	TuTh	1245P-0200P	

## ART

### ART 1A Art History

**Advisory:** Eligible for English 250 and English 260.

**Transferable:** CSU; UC; CSU-GE: C2; IGETC: 3A; GAV-GE: C2; CAN: ART 2, ART SEQ. A

A critical survey of the influences and development of painting, architecture, sculpture, and minor arts from pre-history to the Byzantine/Romanesque eras, including the art of primitive people.

6011	LEC	MHG11	RORABAUGH S	3.00	3.0	W	0630P-0920P	
------	-----	-------	-------------	------	-----	---	-------------	--

**Above class meets at Morgan Hill Community site**

### ART 1B Art History

**Advisory:** Eligible for English 250 and English 260.

**Transferable:** CSU; UC; CSU-GE: C2; IGETC: 3A; GAV-GE: C2; CAN: ART 4, ART SEQ. A

The history of western painting, sculpture, architecture and minor arts from the Romanesque, the Gothic and Renaissance eras to the present.

4078	LEC	AL101	ROIZEN M	3.00	3.0	TuTh	0810A-0925A	1
6012	LEC	HOL1	ROBROCK J	3.00	3.0	W	0630P-0920P	

**Above class meets at the Hollister Briggs site**

### ART 2A Two-Dimensional Design

**Transferable:** CSU; UC; CSU-GE: C1; GAV-GE: C1; CAN: ART 14

An introduction to the basic elements and principles of two-dimensional design. Lettering and graphics applications of design are included. Traditional and experimental materials and techniques are applied to a variety of individual projects and exercises.

4079	L/L	AR103	FRANCO F	6.00	3.0	MW	0810A-1100A	1
------	-----	-------	----------	------	-----	----	-------------	---

### ART 3A Drawing and Composition

**Transferable:** CSU; UC; CSU-GE: C1; GAV-GE: C1; CAN: ART 8

A course that can teach you how to draw. Students learn basic drawing skills through the exploration of a variety of drawing materials such as pencil, inks, charcoal and pastels; processes include doodling, gesture and schematic drawing.

4080	L/L	AR102	R2ROW	6.00	3.0	TuTh	0810A-1100A	
4081	L/L	AR102	R2ROW	6.00	3.0	MWF	1110A-0100P	1

### ART 3B Drawing and Composition

**Advisory:** Art 2A or 3A.

**Transferable:** CSU; UC; GAV-GE: C1

Drawing in pencil, ink, pastels and variety of experimental materials and processes. Cultural awareness and historical foundations are integrated with classroom explorations of expressive drawing. Students develop a variety of drawing approaches and a greater understanding of personal expression. May be repeated once for credit. This course has the option of a letter grade or credit/no credit.

4082	L/L	AR102	R2ROW	6.00	3.0	MWF	0910A-1100A	
------	-----	-------	-------	------	-----	-----	-------------	--

### ART 6 Art Appreciation

**Advisory:** English 250 and English 260.

**Transferable:** CSU; UC; CSU-GE: C1; IGETC: 3A; GAV-GE: C1

An illustrated lecture course that surveys and introduces the visual arts from historical to contemporary times, and teaches students the basic concepts of seeing and appreciating art.

4084	LEC	AL101	EDBERG J	3.00	3.0	MW	1110A-1225P	1
4085	ONLINE	EDBERG J		3.00	3.0	TBA	0000-0000	38

**This online class will be delivered entirely over the internet. After enrolling, start the class by going to <http://www.gavilan.edu/disted/>, click on your class link, and email the instructor at [jedberg@gavilan.edu](mailto:jedberg@gavilan.edu). Students who have not begun the class or contacted the instructor by 5 pm on January 26 will be dropped from the class.**

Sect.	Type	Room	Instructor	Hrs.	Units	Days	Begin-End	Footnotes
-------	------	------	------------	------	-------	------	-----------	-----------

### ART 8A Beginning Black and White Photography

**Transferable:** CSU; UC; CSU-GE: C1; GAV-GE: C1; CAN: ART 18

A beginning black and white photography course focused on the technical and historical aspects of photography as well as the development of personal artistic expression and visual perception through the use of the black and white photographic medium. The course will include lectures and discussions about composition and content, camera use, lighting and exposure, black and white film development, printing and presentation techniques. Alternative methods and experimental forms of black and white photography will also be discussed. Students will be required to provide their own camera, film and photographic paper.

4086	L/L	AR103	EDBERG J	6.00	3.0	TuTh	1110A-0200P
------	-----	-------	----------	------	-----	------	-------------

### ART 10A Cultural History of Ceramics

**Transferable:** CSU; UC; CSU-GE: C1; GAV-GE: C1, F; CAN: ART 6

An introduction to the historical developments and cultural influences of ceramic art. Development of a personal expression is realized through the combination of historical elements, observation and actual creations in clay.

4087	L/L	AR101	REKEDAL J	5.00	3.0	MW	0845A-1100A
6013	L/L	AR101	GONZALES KC	5.00	3.0	TuTh	0630P-0855P

### ART 10B Ceramics

**Advisory:** Art 10A

**Transferable:** CSU; UC; GAV-GE: C1

Emphasis on development of wheel throwing and advanced ceramic techniques. Glaze testing, clay body development, kiln stacking and firing are introduced. May be repeated two times for credit. This course has the option of a letter grade or credit/no credit.

4088	L/L	AR101	REKEDAL J	6.00	3.0	MW	1110A-0200P
6014	L/L	AR101	GONZALES KC	6.00	3.0	TuTh	0630P-0920P

### ART 11 Creativity, Imagination, and Innovation

**Advisory:** English 250 and English 260.

**Transferable:** CSU; CSU-GE: C2; GAV-GE: C2, F

This course is designed to explore the variety of ways in which humans demonstrate their creative, imaginative and innovative abilities. This course will examine the creative process, visual literacy, the development of creative and imaginative performance and theories pertaining to insight, inspiration, intuition, originality and genius. This class draws on materials from a variety of sources including, biographies, intellectual histories, psychological studies, and educational research. Studies will include ideas and beliefs about creativity from a diverse range of disciplines and cultures. Students will be encouraged to explore and express their own creativity.

4089	LEC	AR103	JUNCKER A	3.00	3.0	MW	1110A-1225P
------	-----	-------	-----------	------	-----	----	-------------

### ART 12A Sculpture

**Transferable:** CSU; UC; GAV-GE: C1; CAN: ART 12

An introduction to expressive and technical sculptural processes of selected media such as clay, plaster and wood. May be repeated once for credit. This course has the option of a letter grade or credit/no credit.

4090	L/L	AR101	ALLEN F	4.00	2.0	F	0910A-0100P
------	-----	-------	---------	------	-----	---	-------------

### ART 15A Beginning Painting: Form and Composition

**Advisory:** Art 2A or 3A, or portfolio review of student's work.

**Transferable:** CSU; UC; GAV-GE: C1

This is an introductory painting course. Students will study traditional, contemporary and experimental painting techniques using acrylics and/or oils as the primary media. Emphasis will be placed on foundational concepts and approaches including color, form and composition. May be repeated once for credit. This course has the option of a letter grade or credit/no credit.

4091	L/L	AR102	ROIZEN M	6.00	3.0	TuTh	1110A-0200P
------	-----	-------	----------	------	-----	------	-------------

### ART 15B Beginning Painting: Imagination and Expression

**Advisory:** Art 2A or Art 3A or Portfolio Review

**Transferable:** CSU; UC; GAV-GE: C1

This is an introductory painting course. Students will study traditional, contemporary and experimental painting techniques and media. Social, cultural and historical awareness are integrated with classroom explorations of expressive painting. Students develop a variety of painting approaches and a greater understanding of personal expression. May be repeated once for credit. This course has the option of a letter grade or credit/no credit.

4092	L/L	AR102	ROIZEN M	6.00	3.0	TuTh	1110A-0200P
------	-----	-------	----------	------	-----	------	-------------

Sect.	Type	Room	Instructor	Hrs.	Units	Days	Begin-End	Footnotes
-------	------	------	------------	------	-------	------	-----------	-----------



## Get Fired Up in Ceramics!

### ART 10A / ART 10B

#### Monday/Wednesday mornings

ART 10A sect. 4087 MW 8:45 - 11 am	ART 10B sect. 4088 MW 11:10 am - 2:00 pm
--	--

Instructor: Jane Rekedal AR 101

#### Tuesday & Thursday evenings

ART 10A sect. 6013 TTh 6:30 - 8:55 pm	ART 10B sect. 6014 TTh 6:30 - 9:20 pm
---	---

Instructor: KC Gonzales AR 101

ART 10A fulfills the requirement for transfer to CSU  
ART 10A or 10B fulfill the Gavilan GE requirement for graduation



Sect.	Type	Room	Instructor	Hrs.	Units	Days	Begin-End	Footnotes
-------	------	------	------------	------	-------	------	-----------	-----------

### ART 21 Ancient Americas: A History through Art

**Advisory:** Eligible for English 250.

**Transferable:** CSU; UC; CSU-GE: C2; IGETC: 3A; GAV-GE: C2, F

A critical survey of history through the arts of pre-Columbian natives of North, Central and South America. The course will cover major societies and events from the appearance of major civilizations through the initial colonization efforts of European nations. Due to the distinct history of the Americas, this course uses the arts - architecture, sculpture, ceramics and painting, among others - of ancient societies as a primary source material. This course has the option of a letter grade or credit/no credit. This course is also listed as HIST 21.

4093	LEC	SS111	LUNA E	3.00	3.0	MW	1245P-0200P	
------	-----	-------	--------	------	-----	----	-------------	--

### ART 22 Field Work and Service

**Required:** Learning contracts must be filled out and signed by the student and the supervising instructor.

**Transferable:** CSU

Supervised field work within the college and with local agencies. Students serve in useful group activities in leadership roles prescribed for them by faculty or community agencies. A maximum of six units may be completed. This is a credit/no credit course.

4094	FEX	AR104	EDBERG J	3.00	1.0	DHR	0000-0000	21
4095	FEX	AR101	REKEDAL J	3.00	1.0	DHR	0000-0000	21
4096	FEX	AR102	ROIZEN M	3.00	1.0	DHR	0000-0000	21
4097	FEX	AR109	R2ROW	3.00	1.0	DHR	0000-0000	21
6015	FEX	AR101	GONZALES KC	3.00	.5	DHR	0000-0000	21

### ART 23 Independent Study

**Required:** The study outline prepared by the student and the instructor must be filed with the department and the dean.

**Transferable:** CSU

Designed to afford selected students specialized opportunities for exploring areas at the independent study level. The courses may involve extensive library work, research in the community, or special projects. May be repeated until six units of credit are accrued. This course has the option of a letter grade or credit/no credit.

4098	IND	AR102	FRANCO F	3.00	1.0	DHR	0000-0000	22
4099	IND	AR104	EDBERG J	3.00	1.0	DHR	0000-0000	22
4100	IND	AR104	EDBERG J	6.00	2.0	DHR	0000-0000	22
4101	IND	AR101	REKEDAL J	3.00	1.0	DHR	0000-0000	22
4102	IND	AR101	REKEDAL J	6.00	2.0	DHR	0000-0000	22
4103	IND	AR101	ALLEN F	3.00	1.0	DHR	0000-0000	22
4104	IND	AR102	ROIZEN M	3.00	1.0	DHR	0000-0000	22
4105	IND	AR102	ROIZEN M	6.00	2.0	DHR	0000-0000	22
4106	IND	AR109	R2ROW	3.00	1.0	DHR	0000-0000	22
4107	IND	AR109	R2ROW	6.00	2.0	DHR	0000-0000	22
4108	IND	AR102	FRANCO F	3.00	2.0	DHR	0000-0000	22
6016	IND	AR101	GONZALES KC	3.00	1.0	DHR	0000-0000	22

### ART 25A Art Methods

**Transferable:** CSU; CSU-GE: C1; GAV-GE: C1

Art methods and learning theory for those planning to work with preschool, elementary and secondary school students. Includes art therapy as well as gifted and special learner projects. Two dimensional work in printing, drawing, collage. Also listed as CD 25A.

4109	L/L	AR103	GONZALES KC	6.00	3.0	TuTh&2	0910A-1100A	25
6017	L/L	HOL1	THOMPSON D	6.00	3.0	S&2	0900A-1250P	25 55

**Above class meets at the Hollister Briggs site**

### ART 25B Art Methods

**Transferable:** CSU; GAV-GE: C1

Art methods, creativity and learning theory for those planning to work with preschool, elementary, and secondary school students. Includes art therapy as well as gifted and special learner projects. Three dimensional work in sculpture, bas relief, mobiles, paper mache', plaster, and various 3-D materials. Also listed as CD 25B.

6018	L/L	HOL1	THOMPSON D	6.00	3.0	S&2	0900A-1250P	25 55
------	-----	------	------------	------	-----	-----	-------------	-------

**Above class meets at the Hollister Briggs site**

### ART 40 Art Gallery Assistance

**Transferable:** CSU; GAV-GE: C1

Individualized course in art gallery exhibition techniques and procedures. Students assist in design, installation, publicity, cataloging and removal of exhibitions in the college gallery. May be taken until 4 units are accrued.

4110	FEX	AR109	R2ROW	3.00	1.0	TBA	0000-0000	21
------	-----	-------	-------	------	-----	-----	-----------	----

Sect.	Type	Room	Instructor	Hrs.	Units	Days	Begin-End	Footnotes
-------	------	------	------------	------	-------	------	-----------	-----------

### ART 75 PhotoShop I

**Advisory:** CSIS 124 (Windows Fundamentals), CSIS 2L

**Transferable:** CSU; GAV-GE: C1

This course is based on the software Adobe PhotoShop. Students learn to scan photographs and manipulate them using PhotoShop tool box and special effects filters. They will learn to color correct photos; mask image using channels; create duotone, tritone, and quadtone images; prepare photos for use in printing and on the web. This course has the option of a letter grade or credit/no credit.

4111	L/L	LI128	BEEDER	5.00	3.0	TuTh&2	0945A-1100A	25 35
6019	L/L	MHG5	GRZAN R	5.00	3.0	Tu&2	0630P-0920P	8 25 35

**Above class meets at Morgan Hill Community site**

### ART 77 Introduction to Digital Media

**Advisory:** CSIS 124, CSIS 1, CSIS 2.2L, CSIS 3, or familiarity using the Macintosh or Windows operating systems.

**Transferable:** CSU; UC; GAV-GE: C1

An introduction to the field of digital media, including history, social impact, concepts, career options and industry trends. Applying learned visual and aural design principles, students will explore the use of computer-based tools in the design and production of digital media by creating and editing digital images, sounds, video, animation and text. A comprehensive term project for publication on the web or CD ROM will be required. This course is also listed as CSIS 77 and DM 77. This course has the option of a letter grade or credit/no credit.

4112	L/L	LI128	BEEDER	5.00	3.0	TuTh&2	1245P-0200P	25 35
------	-----	-------	--------	------	-----	--------	-------------	-------

### ART 80 Digital Photography

**Advisory:** CSIS 1 or CSIS 2/2L or ART 8A or equivalent computer experience.

**Transferable:** CSU; UC; GAV-GE: C1

The study of digital photography from digital camera to the computer-based printer or digital media. Artistic, theoretical, and technical aspects will be considered. Topics include information about types and purchasing of digital cameras; theory, mechanics, and art of digital imagery; digital darkroom; eccentricities of digital photo taking; stitching photos for virtual reality; and preparing digital images for print, World Wide Web and other digital media. This course has the option of a letter grade or credit/no credit. This course is also listed as DM 80 and CSIS 80.

4113	L/L	AR103	EDBERG J	5.00	3.0	M&2	1245P-0315P	25 35 95
		LI128	EDBERG J			M	0210P-0325P	

### ART 85 Web Design I: Dreamweaver

**Advisory:** CSIS 6 or basic knowledge of HTML.

**Transferable:** CSU; GAV-GE: C1

Basic and intermediate principles of designing Web pages/sites using the Dreamweaver web design software and HTML. Emphasis will be on good design and the use of tables, frames, forms, rollovers, DHTML, XHTML, behaviors, and CSS. Also includes site maintenance and the integration of multimedia components such as graphics, sound, animation, and video. This course is for the content person to design, develop, and maintain effective Web sites. This course is also listed as CSIS 85 and DM 85. This course has the option of a letter grade or credit/no credit. May be repeated twice for credit.

4114	LEC	BU111	THOMPSON F	4.00	2.0	F	0900A-1250P	11 25
------	-----	-------	------------	------	-----	---	-------------	-------

**03/10/06 - 05/19/06**

### ART 98 Special Topics

**Transferable:** CSU

Special topics courses examine current problems or issues of interest to students within a specific discipline area. For topic content information, consult with the appropriate department chairperson. For transfer status, check with a counselor. This course may have the option of a letter grade or credit/no credit.

6020	LEC	AR102	ROIZEN M	1.00	1.0	TBA	0000-0000	
------	-----	-------	----------	------	-----	-----	-----------	--

### ART 107 Digital Media Design

**Advisory:** CSIS 1 or CSIS 2/2L or equivalent computer experience

**Transferable:** CSU

Fundamentals of design for visual, time-based, interactive, and sound arts as applied to digital media. Includes basic storytelling, graphic design, information architecture, and human factors. Page layout, scripting, storyboards, and flow charts will be used as tools applicable to the design and development of business presentations, interactive media, educational multimedia, animation, web sites, video games, and film/video. This course has the option of a letter grade or credit/no credit. Also listed as CSIS 107 and DM 107.

4115	L/L	LI128	BEEDER	3.00	2.0	W	1245P-0300P	25
------	-----	-------	--------	------	-----	---	-------------	----

Sect.	Type	Room	Instructor	Hrs.	Units	Days	Begin-End	Footnotes
-------	------	------	------------	------	-------	------	-----------	-----------

**ART 108 Digital Media Lab****Advisory:** CSIS 1 or CSIS 2/2L or equivalent computer experience.**Transferable:** CSU

Supervised practice and individualized computer assisted learning of software applications and techniques commonly found in the design and production of digital media (e.g., digital art and imaging, digital photography, digital print, digital audio/video, web design/authoring, DVD/CD ROMs, animation). Supplements lecture courses. Open entry/exit, so may be added at anytime during the semester. Graded credit/no credit only. May be repeated three times for credit. Also listed as DM 108 and CSIS 108.

4116	LAB	LI128	BEEDER	1.50	.5	M	1110A-0150P	25 31
			BEEDER			W	1110A-1215P	
4117	LAB	LI128	EDBERG J	2.00	.5	M	0330P-0520P	25 31

**ART 113 Introduction to Digital Video****Advisory:** CSIS 1 or CSIS 2/2L or equivalent computer experience**Transferable:** CSU

Introduction to the aesthetic and technical aspects of digital video recording, non-linear editing, special effect generation, and production of video (and associated audio) using the personal computer equipped with specialized software such as iMovie, Final Cut Pro, and After Effects. Also considered will be the preparation of digital video for use in interactive media such as CD, DVD, and the World Wide Web. Students will produce a final digital video project on DVD. This course has the option of a letter grade or credit/no credit. May be repeated two times for credit. Also listed as CSIS 113 and DM 113.

4118	L/L	LI128	BEEDER	5.00	3.0	MW&2	0945A-1100A	25 35
------	-----	-------	--------	------	-----	------	-------------	-------

**ART 114 Digital Media Production**

**Advisory:** At least one of the following: ART 75, GBUS 80, CGD 2, JOUR 18A, MUS 21, CSIS 7, CSIS 71 OR CSIS 77. or students must possess equivalent skills from any one of the following areas: digital media, computer graphics, digital print, journalism (publishing), film, TV/video, drawing or illustration, web design/development, business/marketing, or programming.

**Transferable:** CSU

A team oriented practicum that focuses on the application of learned skills to the production of digital media and digital print projects, such as web sites, CD ROM, and DVDs. Project development will be accomplished according to team derived master schedules. Lectures will be on project management, work coordination and production techniques, client-team interface, asset management and integration, budget estimate, testing, and copyright infringement. Please note that this is very much a team oriented class. This course has the option of a letter grade or credit/no credit. This course is also listed as CSIS 114 and DM 114.

4119	LEC	LI128	BEEDER	2.00	2.0	M	1110A-0100P	25
------	-----	-------	--------	------	-----	---	-------------	----

**ART 140 Basic Digital Film/Video Production****Transferable:** CSU; UC

An on-line self-paced course covering the basics of film/video production and post production (editing) using "easy to use" computer software such as Apple's iMovie. Beneficial for students who are producing a video/film project as a requirement for another college course, extra skills development, or for self interest. Completion of the associated class or personal project in DVD format using either personal video equipment or the equipment in the Digital Media Studio is required. May be repeated twice for credit. This course has the option of a letter grade or credit/no credit. This course is also listed as DM 140 and CSIS 140.

4120	ONLINE	BEEDER		1.00	1.0	DHR	0000-0000	25 38
------	--------	--------	--	------	-----	-----	-----------	-------

**This online class will be delivered entirely over the internet. After enrolling, start the class by going to <http://www.gavilan.edu/disted/>, click on your class link, and email the instructor at [rbeede@gavilan.edu](mailto:rbeede@gavilan.edu). Students who have not begun the class or contacted the instructor by 5 pm on January 26 will be dropped from the class.**

**ART 190 Occupational Work Experience/ Commercial Art****Required:** Enrollment in a minimum of seven (7) units, including Cooperative Work Experience, during regular semesters; enrollment in at least one other class in summer session.**Transferable:** CSU

The application of learned theory, knowledge, and skills to a practical job setting related to the student's educational/occupational goal. Employment must be directly related to the student's college educational/occupational goal. Periodic interviews of the students and employers or their representatives will be required. Each student shall be assisted in the development of individualized performance objectives, toward which the learning experience shall be directed.

4121	WEX	SC154S	KERRL	5.00	1.0	DHR	0000-0000	
4122	WEX	SC154S	KERRL	10.00	2.0	DHR	0000-0000	
4123	WEX	SC154S	KERRL	15.00	3.0	DHR	0000-0000	
4124	WEX	SC154S	KERRL	20.00	4.0	DHR	0000-0000	

Sect.	Type	Room	Instructor	Hrs.	Units	Days	Begin-End	Footnotes
-------	------	------	------------	------	-------	------	-----------	-----------

ART 21: THE ART OF ANCIENT AMERICA

section # 4095  
M & W  
12:45 - 2:00  
Instructor:  
Enrique Lima

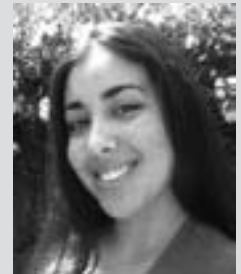
**STUDENT Profile****BETSY AVELAR:**

Betsy Avelar is the Associated Student Body President at Gavilan College. She has attended Gavilan for two years now and is the eldest of seven younger siblings. She is a first generation college student who will double major in literature and mass communications, and her plans are to earn an AA degree in liberal arts at Gavilan College. Her ultimate goals are to transfer to a UC and attend law school to learn immigration law. She is an active member of the church "The Light of the World" and hopes to influence the youth in continuing with higher education.

Learn to create with  
**PHOTOSHOP**  
**ART 75**

Sect. 6019  
Instructor: Raymond Grzan  
Thursday 6:30 - 9:20 pm at the Morgan Hill site



Sect. Type Room Instructor Hrs. Units Days Begin-End Footnotes

**ASTRONOMY****ASTR 1 Introduction to General Astronomy****Advisory:** Mathematics 205 and eligible for English 250 and English 260.**Transferable:** CSU; UC; CSU-GE: B1; IGETC: 5A; GAV-GE: B1

An introduction to the realm of astronomy and space science. Topics to be covered include the historical development of astronomy, the physics of gravitation and radiation, the solar system, stellar astronomy, galactic and extragalactic astronomy, and cosmology.

4125	LEC	SS214	BUMGARNER J	3.00	3.0	Tu	0210P-0500P	
6022	LEC	LS101	SNYDER J	3.00	3.0	W	0630P-0920P	
6023	LEC	MHG3	BUMGARNER J	3.00	3.0	Tu	0645P-0935P	

Above class meets at Morgan Hill Community site

**Athletics: See Physical Education (PE)****AVIATION MAINTENANCE TECHNOLOGY****AMT 101 General Aircraft Technology****Advisory:** Mathematics 205**Transferable:** CSU

This course will provide the student with a thorough understanding of the use of maintenance publications, maintenance forms and records with emphasis on A & P mechanic privileges and limitations. Basic electricity for aircraft from Ohm's Law through transistor theory will be taught as well as ground operation and servicing of aircraft.

4067	L/L	AV102	CONNALD	12.50	7.5	DAILY	0800A-1030A	1 5 28
------	-----	-------	---------	-------	-----	-------	-------------	--------

01/17/06 - 05/26/06 Above class meets at the Hollister Airport

**AMT 111 Airframe Structures****Transferable:** CSU

Aircraft wood, fiberglass construction, fabric covering, testing and repair, aircraft inspection, painting techniques and procedures. Also the study of basic hydraulic systems of anti-skid systems, pneumatic, fixed landing and retractable landing gear systems. Basic aircraft systems familiarization along with advanced laboratory projects from topics covered in AMT 110 are a part of this course.

4068	L/L	AV102	HALL C	22.50	13.5	DAILY	1030A-0330P	1 5 28
------	-----	-------	--------	-------	------	-------	-------------	--------

01/17/06 - 05/26/06 Above class meets at the Hollister Airport

**AMT 121 Aviation Powerplant Systems Technology****Advisory:** Successful completion of AMT 120.**Transferable:** CSU

The theory of operation, maintenance, repair, and trouble-shooting procedures of powerplant systems and their relationship to the total powerplant package. To include lubrication, electrical, instrument, fuel metering, fire protection, starting, control systems, and the aerodynamics, theory and maintenance of propellers and their control systems.

4069	L/L	AV102	FLIPPEN T	24.00	14.0	TuWThF	0830A-0300P	1 5 28
------	-----	-------	-----------	-------	------	--------	-------------	--------

01/17/06 - 05/26/06 Above class meets at the Hollister Airport

**AMT 190 Occupational Work Experience/Aviation****Required:** Declared vocational major. Concurrent in seven or more units (including CWE units, except for summer school. For summer school, enrollment in one other class is required). Minimum 2.00 G.P.A.**Transferable:** CSU

College credit for learning experience obtained on the job in accordance with a training plan developed cooperatively between the employer, college and student. 75 hours per semester per unit or 60 hours per semester for unpaid experience. This is a credit/no credit course. May be taken for a maximum of 16 units of work experience units.

4070	WEX	SC154S	KERRL	5.00	1.0	DHR	0000-0000	16
4071	WEX	SC154S	KERRL	10.00	2.0	DHR	0000-0000	16
4072	WEX	SC154S	KERRL	15.00	3.0	DHR	0000-0000	
4073	WEX	SC154S	KERRL	20.00	4.0	DHR	0000-0000	

**Beauty School: See Cosmetology**

Sect. Type Room Instructor Hrs. Units Days Begin-End Footnotes

**BIOLOGICAL SCIENCE****BIO 5 General Botany****Prerequisite:** Mathematics 233 with a grade of 'C' or better.**Advisory:** Biological Science 10, eligible for English 250 and English 260.**Transferable:** CSU; UC; CSU-GE: B2, B3; IGETC: 5B; GAV-GE: B2, B3; CAN: BIOL 6, BIOL SEQ. A

This course is designed for students majoring in botany and/or its related disciplines. The course includes the study of the ecology, evolution, anatomy, physiology and systematics of plants as well as the use of plants in biotechnology and agriculture.

4131	L/L	LS103	PARMENTER D	6.00	4.0	F	0810A-1100A	1
		LS101	PARMENTER D			TuTh	0945A-1100A	

**BIO 7 Human Anatomy****Prerequisite:** Biological Science 10 or 15 with a grade of credit or C or better.**Advisory:** Eligible for English 250, English 260 and Mathematics 205.**Transferable:** CSU; UC; CSU-GE: B2, B3; IGETC: 5B; GAV-GE: B2, B3; CAN: BIOL 10, BIOL SEQ. B

A functional approach to the gross and microscopic structure of the major systems of the human body. Includes dissection in lab. A cadaver is observed in this course.

4132	L/L	LS103	KEW E	8.00	4.0	WF	1110A-1200P	1
			KEW E				1210P-0300P	

**BIO 9 Human Physiology****Prerequisite:** Biological Science 7 or 15 with a grade of credit or C or better.**Advisory:** Chemistry 30A; eligible for English 250, English 260 and Mathematics 205.**Transferable:** CSU; UC; CSU-GE: B2, B3; IGETC: 5B; GAV-GE: B2, B3; CAN: BIOL 12, BIOL SEQ. B

A study of the functions of the major organs and organ systems of the human body, emphasizing control at the cellular level, integration of systems and homeostasis of the human body. This course is also listed as Allied Health 9.

4133	L/L	LS101	MCKENNA M	7.00	5.0	WF	1110A-0100P	1
		LS103	MCKENNA M			Th	1010A-0100P	
4134	L/L	LS101	MCKENNA M	7.00	5.0	WF	1110A-0100P	1
		LS103	SMITH M			Th	0410P-0700P	
4135	L/L	LS101	MCKENNA M	7.00	5.0	WF	1110A-0100P	1
		LS103	SMITH M			Th	0110P-0400P	

**BIO 10 Principles of Biology****Advisory:** Eligible for English 250, English 260 and Mathematics 205.**Transferable:** CSU; UC; CSU-GE: B2, B3; IGETC: 5B; GAV-GE: B2, B3

An introductory biology course covering functions at the cellular and organismal levels. Includes study of the basic principles of metabolism, heredity, evolution and ecology. Primarily for non-biological science majors.

4136	L/L	SS214	MORALES R	5.00	4.0	MW	0215P-0330P	1
		LS103	MORALES R			M	0810A-1000A	
4137	L/L	SS214	MORALES R	5.00	4.0	MW	0215P-0330P	1
		LS103	HUBBARD J			M	0345P-0535P	
4138	L/L	SS214	MORALES R	5.00	4.0	MW	0215P-0330P	1
		LS103	MORALES R			W	0810A-1000A	
4139	L/L	SS214	MORALES R	5.00	4.0	MW	0215P-0330P	1
		LS103	MORALES R			W	0345P-0535P	
6024	L/L	LS102	GEMAR A	5.00	4.0	TuTh	0630P-0845P	

**BIO 11 Nutrition****Prerequisite:** Eligible for English 250 and English 260**Advisory:** Chemistry 30A and Mathematics 205**Transferable:** CSU; UC; CSU-GE: E2; GAV-GE: E2; CAN: FCS 2

This course is designed to meet the needs of the Allied Health student and the general education student alike. The major aim of this course is to help the student acquire relevant information about nutrition which they can use professionally and/or personally. The course will cover the practical aspects of normal nutrition, ways to promote sound eating habits throughout the life cycle, and physiological contribution nutrients make to body structure and function. This course is also listed as Allied Health 11.

4140	LEC	LS104	AKROP M	3.00	3.0	Tu	0110P-0400P	25
4141	LEC	LS104	AKROP M	3.00	3.0	Tu	0410P-0700P	25
4142		ONLINE	AKROP M	3.00	3.0	TBA	0000-0000	25 38

 This online class will be delivered entirely over the internet. After enrolling, start the class by going to <http://www.gavilan.edu/disted/>, click on your class link, and email the instructor at [makrop@gavilan.edu](mailto:makrop@gavilan.edu). Students who have not begun the class or contacted the instructor by 5 pm on January 26 will be dropped from the class.

Sect. Type Room Instructor Hrs. Units Days Begin-End Footnotes

**BIO 15 Survey of Human Anatomy and Physiology****Advisory:** Biological Science 10, Eligible for English 250, English 260 and Mathematics 205.**Transferable:** CSU; UC; CSU-GE: B2, B3; IGETC: 5B; GAV-GE: B2, B3

An introductory study of the structure and function of the human body. Includes study at the cellular and organ system levels, emphasizing integration of systems. Note that a cadaver will be observed in this course. This course is also listed as Allied Health 15.

4143	L/L	LS101 LS103	MCKENNA M STAFF	7.00 5.0	MW Tu	0845A-1035A 1210P-0300P	125 77
4144	L/L	LS101 LS103	MCKENNA M MCKENNA M	7.00 5.0	MW Tu	0845A-1035A 0910A-1200P	125 77
4145	L/L	LS101 LS103	MCKENNA M MCKENNA M	7.00 5.0	MW M	0845A-1035A 1110A-0200P	125 77
6025	L/L	LS103	HUBBARD J	7.00 5.0	MW	0600P-0930P	

**BIO 21 Field Ecology****Advisory:** Eligible for English 250 and Math 205.**Transferable:** CSU

Introduces concepts in ecology, plant and animal identification, and habitat assessment in a field setting. Students should be prepared for primitive camping and long hours of intensive learning. This course has the option of a letter grade or credit/no credit.

6026	LEC	LS101	WILLETT T	1.00 1.0	M F S SUN	0500P-0600P 0500P-0800P 0800A-0500P 0800A-0300P	20 65
------	-----	-------	-----------	-------------	--------------------	--	-------

**04/24/06 - 04/30/06** Class will meet on Monday, April 24, 2006 in LS101 for a lecture and to discuss preparations for the field component of the class. Class will meet Friday, April 28th at Big Basin Redwood State Park and camp Friday and Saturday nights. Sunday the class will take a day trip to nearby Castle Rock State Park.

**BIO 23 Independent Study****Required:** The study outline prepared by the student and the instructor must be filed with the department and the dean.**Transferable:** CSU

Designed to afford selected students specialized opportunities for exploring areas at the independent study level. The courses may involve extensive library work, research in the community, or special projects. May be repeated until six units of credit are accrued. This course has the option of a letter grade or credit/no credit.

4146	IND	LS109	MCKENNA M	6.00 2.0	DHR	0000-0000	22
4147	IND	LS110	MCKENNA M	3.00 1.0	DHR	0000-0000	22

**Business Accounting: See Accounting****BUSINESS, GENERAL****GBUS 1 Fundamentals of Business****Advisory:** Eligible for English 250 and English 260.**Transferable:** CSU; UC; GAV-GE: D2

This course introduces students to business and the array of opportunities that it offers. The course will help students recognize careers that will be of interest to them with consideration of their own skills and aptitudes. Different facets of business will be covered and students will learn about establishing their own business. This course has the option of a letter grade or credit/no credit.

4405	LEC	BU118	ROBINSON V	3.00 3.0	TuTh	1110A-1225P	
------	-----	-------	------------	-------------	------	-------------	--

**GBUS 11 Statistics for Business and Economics****Prerequisite:** Mathematics 233.**Transferable:** CSU; UC; CSU-GE: B4; IGETC: 2A; GAV-GE: B4

Statistical methods for business/economics analysis; descriptive statistics, inference, correlation and regression, probability, time series analysis. This course has the option of a letter grade or credit/no credit. This course is also listed as ECON 11.

4406	LEC	BU120	LITTIG A	4.00 4.0	MW	1245P-0235P	25
------	-----	-------	----------	-------------	----	-------------	----

**Be Aware**

You MAY NOT take courses that overlap (courses that meet at the same day and time)!

Sect. Type Room Instructor Hrs. Units Days Begin-End Footnotes

**The Sky is the Limit!****At the Gavilan Aviation Maintenance Technology Program**

Unlimited Employment Opportunities • Graduates can earn up to \$30 an hour

Internships Available • Accredited by the Federal Aviation Administration

Receive Both Airframe and Powerplant Licenses in 4 Semesters

Fast and Easy Commute to Training Program



For complete program information, please contact the Aviation Department at the Hollister Airport (831) 637-1151 or the Technical and Public Services Division at Gavilan (408) 848-4719

**GAVILAN LIBRARY DATABASES**

available to Gavilan students through home Internet connections



All of the databases are linked from [www.gavilan.edu/library](http://www.gavilan.edu/library). Call the reference desk at 848-4806 to obtain the secret access codes.

**ECON 11/GBUS 11 Business Statistics**

4 UNITS

This class fulfills your CSU and UC transfer requirements

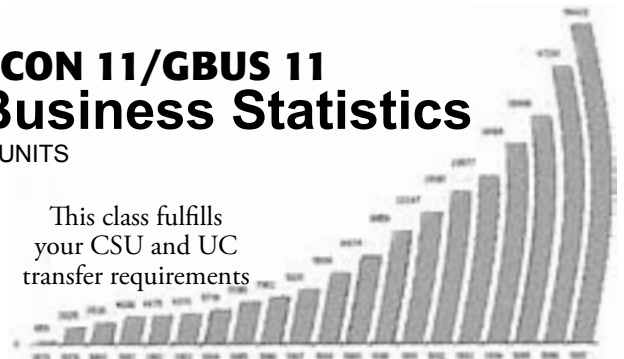

Sections 4290/4406

Mon/Wed

12:45 - 2:35 pm

BU120

Sect.	Type	Room	Instructor	Hrs.	Units	Days	Begin-End	Footnotes
-------	------	------	------------	------	-------	------	-----------	-----------

**GBUS 80 Business Law****Advisory:** Eligible for English 250 and English 260.**Transferable:** CSU; UC; CAN: BUS 12

Introduction to the law applicable to business institutions and their operations; social forces and their effect upon the development of law; sources of law, agencies for enforcement, and court procedure and administration agencies. Substantive law, that law which includes rights and duties, will include contracts, agency employment relationships, torts and crimes. This course has the option of a letter grade or credit/no credit.

6102	LEC	MHG4	DEWOLF	3.00	3.0	Th	0600P-0850P	
<b>Above class meets at Morgan Hill Community site</b>								
6103	LEC	BU120	SHARMA S G	3.00	3.0	M	0630P-0920P	

**BUSINESS OFFICE TECHNOLOGY****BOT 112 Business Computations with Machines****Advisory:** Eligible for Mathematics 402.**Transferable:** CSU

Self-paced course in the operation of the electronic printing calculator. This course provides theory and practice in business applications with emphasis on mathematical problem solving. This course has the option of a letter grade or credit/no credit.

4148	LAB	BU110	GAFFNEY S	1.50	.5	DHR	0000-0000	7 9
------	-----	-------	-----------	------	----	-----	-----------	-----

**BOT 180 Medical Terminology for the Office****Advisory:** Eligible for English 250 and English 260.**Transferable:** CSU

This course introduces fundamentals of medical word building used in the health profession (prefixes, word roots, suffixes and abbreviations) as well as review of body systems, with emphasis on analysis, definition, spelling and pronunciation. This course had the option of a letter grade or credit/no credit.

4149	LEC	MHG10	KNAPP D	3.00	3.0	Tu	0310P-0600P	96
<b>Above class meets at Morgan Hill Community site</b>								

**BOT 181 Medical Billing - MediSoft****Advisory:** Eligible for English 250. Some computer experience.**Transferable:** CSU

This course in computerized billing procedures for a medical office uses MediSoft software. Students will learn the patient billing features of this software and complete a capstone simulation giving them hands-on realistic medical front office practice. This course has the option of a letter grade or credit/no credit. May be repeated three times for credit.

6027	L/L	BU110	KNAPP D	4.00	2.0	M	0600P-0850P	96
------	-----	-------	---------	------	-----	---	-------------	----

**BOT 182 Medical Office Procedures****Prerequisite:** BOT 180 and CSIS 126 with credit or a grade of C or better or experience using Microsoft Word.**Advisory:** Eligible for English 250 and Mathematics 402.**Transferable:** CSU

This specialized course includes medical office procedures, patient record management, coding/billing for private/government health insurance programs, and professional ethics. May be repeated three times for credit. This course has the option of a letter grade or credit/no credit.

6028	L/L	BU110	KNAPP D	5.00	3.0	Th&1	0600P-0850P	35 96
------	-----	-------	---------	------	-----	------	-------------	-------

**BOT 190 Occupational Work Experience/Business Office Technology****Required:** Declared vocational major. Concurrent enrollment in seven or more units (including CWE units, except for summer school. For summer school enrollment in one other class is required). Minimum 2.00 G.P.A.**Transferable:** CSU

College credit for learning experience obtained on the job in accordance with a training plan developed cooperatively between the employer, college and student. 75 hours per semester per unit or 60 hours per semester for unpaid experience. This is a credit/no credit course. May be taken for a maximum of 16 work experience units.

4150	WEX	SC154S	KERRL	5.00	1.0	DHR	0000-0000	16
4151	WEX	SC154S	KERRL	10.00	2.0	DHR	0000-0000	16
4152	WEX	SC154S	KERRL	15.00	3.0	DHR	0000-0000	16
4153	WEX	SC154S	KERRL	20.00	4.0	DHR	0000-0000	

Sect.	Type	Room	Instructor	Hrs.	Units	Days	Begin-End	Footnotes
-------	------	------	------------	------	-------	------	-----------	-----------

**Ceramics: See Art****CHEMISTRY****CHEM 1B General Chemistry****Prerequisite:** Chemistry 1A with a grade of C or better.**Transferable:** CSU; UC; CSU-GE: B1, B3; IGETC: 5A; GAV-GE: B1, B3; CAN: CHEM 4, CHEM SEQ. A

This is the second semester of a year-long general chemistry course designed as a continuation of Chemistry 1A. Topics include solutions, thermodynamics, chemical kinetics, the equilibria of acids and bases, solubility systems, complex ions, electrochemistry, the chemistry of metals and nonmetals, as well as nuclear chemistry.

4183	LEC	LS102	CLARK D	7.00	5.0	MW	0945A-1100A	1
		CH101	CLARK D			Tu	0945A-1225P	
		CH109	CLARK D			F	1010A-1100A	

**CHEM 12B Organic Chemistry****Prerequisite:** Chemistry 12A**Transferable:** CSU; UC; CSU-GE: B1, B3; IGETC: 5A; GAV-GE: B1, B3

This is the second semester of a year-long organic chemistry course designed as a continuation of Chemistry 12A. Topics include nomenclature, stereochemistry, mechanism, reactions, and spectroscopic studies of the various organic functional groups. Lecture and laboratory methods will focus on synthesis, isolation, purification, elucidation and identification of organic structures as well as instrumental methods and data interpretation.

4184	L/L	LS102	CLARK D	9.00	5.0	TuTh	1245P-0200P	
		CH101	CLARK D			TuTh	0210P-0500P	

**CHEM 30A Elementary Chemistry****Advisory:** Mathematics 205; eligible for English 250 and English 260.**Transferable:** CSU; UC; CSU-GE: B1, B3; IGETC: 5A; GAV-GE: B1, B3; CAN: CHEM 6, CHEM SEQ. B

This is a first semester chemistry course designed for majors preparing to take Chemistry 1A, nursing and allied health students as well as general education. The course will cover the principles of chemistry including properties of matter, energy, atomic theory, the Periodic Table, stoichiometry, elements and compounds, the properties of bonding molecular structure, chemical reactions, states of matter, acidic solutions and gases, as well as an introductory to organic chemistry.

6045	L/L	CH109	CLARK D	6.00	4.0	TuTh	0600P-0850P	
------	-----	-------	---------	------	-----	------	-------------	--

**CHEM 30B Elementary Organic and Biochemistry****Prerequisite:** Chemistry 30A with a grade of C or better.**Transferable:** CSU; UC; CSU-GE: B1, B3; IGETC: 5A; GAV-GE: B1, B3; CAN: CHEM 8, CHEM SEQ. B

Hydrocarbons, alcohols, aldehydes, ketones, carboxylic acids, amines, carbohydrates, lipids, proteins and their functions in physiological systems.

4185	L/L	LS102	CLARK D	6.00	4.0	MW	0810A-0925A	1
		CH101	CLARK D			Th	0945A-1225P	

**CHILD DEVELOPMENT****CD 1 Principles and Philosophies of Early Childhood Education****Advisory:** Eligible for English 250 and English 260.**Transferable:** CSU

An overview of current educational theories and research, as well as an historical perspective on the development of early childhood education. Observations in schools are to be arranged.

4155	LEC	BU117	SEGAL M	3.00	3.0	TuTh	0945A-1100P	
6029	LEC	MHG3	SHARPE E	3.00	3.0	S	0830A-0300P	34 57
<b>01/28/06 - 05/13/06 Esta sección sera enseñada en Español. Above class meets at Morgan Hill Community site.</b>								

**TBA**

means that the class has a flexible schedule. For details, contact the instructor.

Sect. Type Room Instructor Hrs. Units Days Begin-End Footnotes

**CD 2 Early Child Development****Advisory:** Eligible for English 250 and English 260; transfer students consult with advisor.**Transferable:** CSU; UC; CSU-GE: D9, E; IGETC: 4I; GAV-GE: D2

A systematic study of the child from prenatal life through the preschool years. The course integrates the basic concepts of physical, cognitive and psychosocial development at each major stage of life during this period. This course is also listed as PSYC 2. This course has the option of a letter grade or credit/no credit.

4156 LEC/online SS210 CLABAUGH D 3.00 3.0 TuTh 1110A-1220P 13 25

**H** This HYBRID lecture/online class will be delivered partially over the internet. Come to the campus for the first day of class.

4157 ONLINE BUMGARNER M 3.00 3.0 DHR 0000-0000 25 38

**Online** This online class will be delivered entirely over the internet. After enrolling, start the class by going to <http://www.gavilan.edu/disted/>, click on your class link, and email the instructor at [mbugarnar@gavilan.edu](mailto:mbugarnar@gavilan.edu). Students who have not begun the class or contacted the instructor by 5 pm on January 26 will be dropped from the class.

6030 LEC SS205 SHARPE E 3.00 3.0 Th 0630P-0920P 25 34  
Esta sección sera enseñada en Español.**CD 3 Child Growth and Development During the School Years****Advisory:** Eligible for English 250 and English 260; Child Development 2; transfer students consult with advisor.**Transferable:** CSU; UC; CSU-GE: D9, E; IGETC: 4I; GAV-GE: D2

Continuation of the study of the principles of child development with emphasis on children from six years through adolescence. Includes developmental theories and topics relevant to these ages. This course is also listed as PSYC 3. This course has the option of a letter grade or credit/no credit.

4158 LEC MHG4 BUMGARNER M 3.00 3.0 MW 1030A-1145A 25

Above class meets at Morgan Hill Community site

6031 LEC HOL2 BROWN R 3.00 3.0 M 0600P-0850P 25

Above class meets at the Hollister Briggs site

**CD 4 Observing and Assessing Children****Advisory:** Eligible for English 250 and English 260 and completion of CD2.**Transferable:** CSU

Provides training in a variety of naturalistic and formal observation techniques, and discusses the use of standardized testing in children. Students learn to use formal observation tools, make a case study portfolio and give a parent conference. Observing children in classroom settings is required. This course has the option of a letter grade or credit/no credit.

6032 LEC SS205 BUMGARNER M 3.00 3.0 M 0600P-0850P

**CD 5 Child, Family, and Community****Advisory:** Eligible for English 250 and English 260.**Transferable:** CSU

Patterns of child-rearing in contemporary society. Interaction of family, school and community. Significance of personal and social values in family life and community action. Individual and social resources for family life including health, welfare and improving child development.

4159 LEC BU117 SEGAL M 3.00 3.0 TuTh 0810A-0920A

**CD 8B Teaching Reading and Writing to Children****Advisory:** Completion of English 250, English 260 or equivalent.**Transferable:** CSU

This course is designed to teach prospective teachers how a child learns to read and write successfully in school. Specific techniques will be taught. Students will be expected to register concurrently in 1-4 units of CD 190--Cooperative Work Experience in order to facilitate opportunities to work regularly with children. This course has the option of a letter grade or credit/no credit.

6033 LEC HOL1 MALASPINA B 3.00 3.0 Tu 0600P-0850P

Above class meets at the Hollister Briggs site

**CD 10 Children with Special Needs****Advisory:** Eligible for English 250 and English 260. Completion of CD 2.**Transferable:** CSU

An introductory course in special education, which includes a survey of special needs such as learning disabilities, emotional disturbances, developmental delays, physical limitations, cognitive differences, and giftedness. Students will study the history of special education and legislation in the USA, ethical assessment and family-based intervention techniques, diversity and family issues, advocacy for special needs children, and the use of technology in special education environments. This course has the option of a letter grade or credit/no credit.

6034 LEC MHG10 CLABAUGH D 3.00 3.0 Th 0600P-0850P

Above class meets at Morgan Hill Community site

Sect. Type Room Instructor Hrs. Units Days Begin-End Footnotes

**Complete your year of Organic Chemistry here at Gavilan College!****CHEM 1B General Chemistry**  
sect. 4183

The second semester of a year-long General Chemistry course designed as a continuation of Chemistry 1A.

*Chem 1B is a prerequisite for Chem 12A (taught in the fall semester)***CHEM 12B Organic Chemistry**  
sect. 4184

The second semester of a year-long Organic Chemistry course designed as a continuation of Chemistry 12A.

Instructor for both courses: Dr. Dale Clark

These courses satisfy Science major prerequisites and the Physical Science requirement for transfer to both The California State University and the University of California Systems.

**CD 4 Observing and Assessing Children****Advisory:** Eligible for English 250 and English 260 and completion of CD2.**Transferable:** CSU

Provides training in a variety of naturalistic and formal observation techniques, and discusses the use of standardized testing in children. Students learn to use formal observation tools, make a case study portfolio and give a parent conference. Observing children in classroom settings is required. This course has the option of a letter grade or credit/no credit.

6032 LEC SS205 BUMGARNER M 3.00 3.0 M 0600P-0850P

**CD 5 Child, Family, and Community****Advisory:** Eligible for English 250 and English 260.**Transferable:** CSU

Patterns of child-rearing in contemporary society. Interaction of family, school and community. Significance of personal and social values in family life and community action. Individual and social resources for family life including health, welfare and improving child development.

4159 LEC BU117 SEGAL M 3.00 3.0 TuTh 0810A-0920A

**CD 8B Teaching Reading and Writing to Children****Advisory:** Completion of English 250, English 260 or equivalent.**Transferable:** CSU

This course is designed to teach prospective teachers how a child learns to read and write successfully in school. Specific techniques will be taught. Students will be expected to register concurrently in 1-4 units of CD 190--Cooperative Work Experience in order to facilitate opportunities to work regularly with children. This course has the option of a letter grade or credit/no credit.

6033 LEC HOL1 MALASPINA B 3.00 3.0 Tu 0600P-0850P

Above class meets at the Hollister Briggs site

**CD 10 Children with Special Needs****Advisory:** Eligible for English 250 and English 260. Completion of CD 2.**Transferable:** CSU

An introductory course in special education, which includes a survey of special needs such as learning disabilities, emotional disturbances, developmental delays, physical limitations, cognitive differences, and giftedness. Students will study the history of special education and legislation in the USA, ethical assessment and family-based intervention techniques, diversity and family issues, advocacy for special needs children, and the use of technology in special education environments. This course has the option of a letter grade or credit/no credit.

6034 LEC MHG10 CLABAUGH D 3.00 3.0 Th 0600P-0850P

Above class meets at Morgan Hill Community site

**ALUMNI***Profile***EDUARDO CERVANTES:**

I graduated from San Benito High School in 1997. I then attended Gavilan College where I earned an A.A. Degree in Liberal Studies. After graduating from Gavilan College, I transferred to U.C. Santa Cruz where I majored in Sociology. While I was at U.C. Santa Cruz I was lucky to participate in several undergraduate fellowship programs. One was the Faculty Mentorship Program and the other was the Undergraduate Research Assistantship Program. Both programs helped me to prepare for graduate school, and gave me the opportunity to work on both my own personal research as well as the research of my mentor/professor for a book and other publications. After I graduated from UCSC I went on to graduate school at Stanford University where I earned a M.A. in Education.

I have worked in the field of Education in various capacities for about six years. Prior to working at Gavilan College I worked as the Program Coordinator for U.C. Santa Cruz's Chicano Latino Resource Center/Ethnic Resource Centers.

In MESA students receive the resources, support and Empowerment to achieve their educational and personal goals. Every MESA student shares the goal of transferring to a four-year university to major in a math or science based discipline.



Sect.	Type	Room	Instructor	Hrs.	Units	Days	Begin-End	Footnotes
-------	------	------	------------	------	-------	------	-----------	-----------

### CD 11A Administration of Programs for Young Children

**Advisory:** Child Development 1 and 2.

**Transferable:** CSU

The principles and practices of the organization and administration of facilities for preschool aged children. Areas covered include organizational structure, budgeting, personnel policies and practices, records, statistics, reporting, relationship with community resources, regulatory agencies, and parents.

6035	LEC	MHG4	MALASPINA B	8.00	3.0	S	0800A-0400P	11 58
------	-----	------	-------------	------	-----	---	-------------	-------

03/25/06 - 05/13/06 Above class meets at Morgan Hill Community site

### CD 12 Computer Education for Teachers

**Advisory:** CSIS 122 Computer Keyboarding, or equivalent; English 250 with a grade of C or better.

**Transferable:** CSU

The history, uses and development of computers in education. Basic computer skills and terminology will be taught in the context of teacher education. Students who successfully complete this course will understand general and specific skills and knowledge required to meet the Technology Standard for Multiple and Single Subject Credential Candidates. This course has the option of a letter grade or credit/no credit. This course is also listed as CSIS 9.

6036	LEC/online	MHG8	CLABAUGH D	8.00	3.0	S	0900A-0430P	11 13 25
------	------------	------	------------	------	-----	---	-------------	----------

01/23/06 - 03/18/06 This HYBRID lecture/online class will be delivered partially over the internet. Come to the campus for the first day of class. The above class meets at Morgan Hill Community site.

### CD 13 Infant and Toddler Development and Care

**Advisory:** Eligible for English 250 and English 260. Child Development 2.

**Transferable:** CSU

Students will study the developmental stages of growth specific to infants and toddlers and learn how to foster positive techniques for nurturing infants and toddlers in group settings. Students will study the RIE philosophy and learn how to observe children in child care and home day care settings. This course has the option of a letter grade or credit/no credit.

6037	LEC	MHG11	SEGAL M	3.00	3.0	Tu	0600P-0850P	
------	-----	-------	---------	------	-----	----	-------------	--

Above class meets at Morgan Hill Community site

### CD 14A Working with School Age Children

**Advisory:** Eligible for English 250 and 260. Child Development 3.

**Transferable:** CSU

Students will learn the developmental characteristics of school aged children, issues relating to before and after school programs for children from kindergarten to grade eight, and specific details of administering and leading such a program. Other topics include recreation versus academic enrichment, staffing requirements, age groupings, program content, and community resources. This course has the option of a letter grade or credit/no credit.

4160	ONLINE	BUMGARNER M	3.00	3.0	DHR	0000-0000	38
------	--------	-------------	------	-----	-----	-----------	----

This online class will be delivered entirely over the internet. After enrolling, start the class by going to <http://www.gavilan.edu/disted/>, click on your class link, and email the instructor at [mbumgarner@gavilan.edu](mailto:mbumgarner@gavilan.edu). Students who have not begun the class or contacted the instructor by 5 pm on January 26 will be dropped from the class.



### CD 19 Introduction to Careers with Children

**Advisory:** Eligible for English 250 and English 260.

**Transferable:** CSU

An overview of Department of Social Services and Department of Education regulations regarding child care workers in California. Self-assessment techniques with emphasis on teacher-child and teacher-adult relationships and personal evaluations. Basic principles of curriculum development and discipline techniques. This course has the option of a letter grade or credit/no credit.

4162	LEC	MHG4	BUMGARNER M	2.00	2.0	MW	1200P-1250P	
------	-----	------	-------------	------	-----	----	-------------	--

Above class meets at Morgan Hill Community site

### CD 22 Field Work and Service

**Required:** Learning contracts must be filled out and signed by the student and the supervising instructor.

**Transferable:** CSU

Supervised field work within the college and with local agencies. Students serve in useful group activities in leadership roles prescribed for them by faculty or community agencies. A maximum of six units may be completed.

4163	FEX	SS202A	BUMGARNER M	3.00	1.0	TBA	0000-0000	21 73
------	-----	--------	-------------	------	-----	-----	-----------	-------

Sect.	Type	Room	Instructor	Hrs.	Units	Days	Begin-End	Footnotes
-------	------	------	------------	------	-------	------	-----------	-----------

### CD 23 Independent Study

**Required:** The study outline prepared by the student and the instructor must be approved by the department and the dean.

**Transferable:** CSU

Designed to afford selected students specialized opportunities for exploring areas at the independent study level. The courses may involve extensive library work, research in the community, or special projects. May be repeated three times or until six units of credit are accrued. This course has the option of a letter grade or credit/no credit.

4164	IND	SS202A	BUMGARNER M	3.00	1.0	TBA	0000-0000	22 73
4165	IND	CD131	SEGAL M	3.00	1.0	DHR	0000-0000	

### CD 25A Art Methods

**Transferable:** CSU; CSU-GE: C1; GAV-GE: C1

Art methods and learning theory for those planning to work with preschool, elementary and secondary students. Includes art therapy as well as gifted and special learner projects. Two dimensional work in printing, painting, drawing, collage. Also listed as ART 25A.

4166	L/L	AR103	GONZALES KC	6.00	3.0	TuTh&2	0910A-1100A	25
6039	L/L	HOL1	THOMPSON D	6.00	3.0	S&2	0900A-1250P	25

Above class meets at the Hollister Briggs site

### CD 25B Art Methods

**Transferable:** CSU; GAV-GE: C1

Art methods, creativity and learning theory for those planning to work with preschool, elementary, and secondary school students. Includes art therapy as well as gifted and special learner projects. Three dimensional work in sculpture, bas relief, mobiles, paper mache', plaster, and various 3-D materials. Also listed as ART 25B.

6040	L/L	HOL1	THOMPSON D	6.00	3.0	S&2	0900A-1250P	25
------	-----	------	------------	------	-----	-----	-------------	----

Above class meets at the Hollister Briggs site

### CD 28A Child Dev & Guidance for Family Child Care/Foster Care

**Transferable:** CSU

An overview of the development of young children from pre-birth through age twelve, primarily designed for the family child care provider or foster parent. Students will be exposed to appropriate expectations and developmentally appropriate learning experiences for each stage of development. Six 3-hour sessions, or may be taught on three Saturdays. This course has the option of a letter grade or credit/no credit.

6041	LEC	BU118	SHARPE E	3.00	1.0	M	0630P-0920P	11 34
------	-----	-------	----------	------	-----	---	-------------	-------

02/13/06 - 04/10/06 Esta sección sera enseñada en Español.

### CD 28C Administering A Family Child Care Home

**Transferable:** CSU

Learning to establish and enforce contracts and policies, marketing your business, being professional in a caring profession, child abuse reporting requirements, licensing regulations for family child care, and the basics of record keeping techniques for family child care. Six 3-hour sessions, or may be taught on three Saturdays. This course has the option of a letter grade or credit/no credit.

6042	LEC	CD127	ALONZO S	8.00	1.0	F	0600P-0850P	11
			ALONZO S			S	0900A-0400P	

03/10/06 - 03/18/06

### CD 30B Teaching Practices and Techniques II

**Advisory:** Child Development 30A. Concurrent enrollment in CD 190.4155

**Transferable:** CSU

Continuation of CD 30A with emphasis on assessment, conferencing and planning skills. Completion of 30A and 30B fulfills State Child Development Permit requirements, and satisfies the associate degree student teaching requirements.

6043	LEC	MHG4	SEGAL M	3.00	3.0	W	0600P-0850P	
------	-----	------	---------	------	-----	---	-------------	--

Above class meets at Morgan Hill Community site

## Can't tell a section number from a course number?

Check out "How to Use this Schedule" on page 36 of this publication.

Sect. Type Room Instructor Hrs. Units Days Begin-End Footnotes

**CD 190 Occupational Work Experience/Child Development**

**Required:** Declared vocational major. Concurrent enrollment in seven or more units (including CWE units, except for summer school. For summer school, enrollment in one other class is required). Minimum 2.00 G.P.A.

**Transferable:** CSU

College credit for learning experience obtained on the job in accordance with a training plan developed cooperatively between the employer, college and student. 75 hours per semester per unit or 60 hours per semester for unpaid experience. This is a credit/no credit course. May be taken for a maximum of 16 work experience units.

4167	WEX	CD131	SEGAL M	5.00	1.0	TBA	0000-0000	14
4168	WEX	CD131	SEGAL M	10.00	2.0	TBA	0000-0000	14
4169	WEX	CD131	SEGAL M	15.00	3.0	TBA	0000-0000	14
4170	WEX	CD131	SEGAL M	20.00	4.0	TBA	0000-0000	14
4171	WEX	SS107	BUMGARNER M	5.00	1.0	TBA	0000-0000	71

**COMMUNICATIONS**

**CMUN 1A Introduction to Public Speaking**

**Advisory:** Eligible for English 250 and English 260.

**Transferable:** CSU; UC; CSU-GE: A1; IGETC: 1C; GAV-GE: A1; CAN: SPCH 4

Basic principles of effective human communication and their function in contemporary public settings; emphasis is on the speech to inform, with special consideration given to fundamental communication skills, including organization, reasoning, explanation and listening.

4186	LEC	TH127	STAFF	3.00	3.0	MW	0810A-0925A	
4187	LEC	TH127	PAULSON M	3.00	3.0	TuTh	0810A-0925A	
4188	LEC	MHG12	STAFF	3.00	3.0	TuTh	0900A-1015A	
<b>Above class meets at Morgan Hill Community site</b>								
4189	LEC	TH127	PAULSON M	3.00	3.0	TuTh	0945A-1100A	
4190	LEC	LI171	ANDRADE A	3.00	3.0	MW	1110A-1225P	
4191	LEC	TH127	BESSON D	3.00	3.0	TuTh	1110A-1225P	
4192	LEC	TH127	BESSON D	3.00	3.0	TuTh	1245P-0200P	43
6046	LEC	TH127	PALMA J	3.00	3.0	Tu	0630P-0920P	

**CMUN 2 Oral Reading**

**Advisory:** Eligible for English 250 and English 260.

**Transferable:** CSU; UC; CSU-GE: C1; GAV-GE: C1

An introduction to the analysis, preparation and dramatic reading of literature, including classical and contemporary prose, poetry and drama. Students will prepare, analyze and orally present and interpret great works of drama and literature for an audience. This course is also listed as THEA 4.

4193	LEC	TH125	THOMPSON R	3.00	3.0	MW	1110A-1225P	25
------	-----	-------	------------	------	-----	----	-------------	----

**CMUN 4 Intercultural Communication**

**Transferable:** CSU; UC; CSU-GE: D3, D7; IGETC: 4G; GAV-GE: D2, F

This course will explore the dynamics of communication as it applies to people from different cultures. Course content focuses on the application of theory and research to intercultural communication contexts. Increasing the awareness and understanding of diversity, the perception process, culture, verbal and non-verbal communication and the obstacles that prevent one from becoming a competent intercultural communicator will be examined.

4194	LEC	TH127	STAFF	3.00	3.0	MW	0945A-1100A	
------	-----	-------	-------	------	-----	----	-------------	--

**CMUN 8 Interpersonal Communication**

**Transferable:** CSU; UC; CSU-GE: A1; IGETC: 1C; GAV-GE: A1

This course studies the communication process in an interpersonal (dyadic) setting. This class will explore the ways in which we can improve our communication with others. Verbal and nonverbal messages, self-concept, cultural differences, gender differences, perception, listening and conflict management will be explored.

4195	LEC	TH127	BESSON D	3.00	3.0	MW	1110A-1225P	
------	-----	-------	----------	------	-----	----	-------------	--

**For on-campus child care**  
contact the Child Development Center at (408) 848-4815

Sect. Type Room Instructor Hrs. Units Days Begin-End Footnotes

**Earn a Certificate of Achievement in Communication Studies**

Gavilan Community College is now offering a Certificate of Achievement in Communication Studies to students who successfully complete **12 units** of communication studies coursework. This certificate will inform future employers, college admissions offices and professional institutions that you have received specialized training in communication skills. This certificate can accompany any degree and enhance your qualifications for the job or university you desire.

Take this opportunity to learn skills that will increase your understanding of yourself, your relationships and your ability to communicate with other people. The Communication Studies Department welcomes you and encourages you to pursue this certificate and empower yourself.

**Classes applicable toward a Certificate of Achievement**

- CMUN 1A
- CMUN 2
- CMUN 4
- CMUN 5
- CMUN 8
- CMUN 10
- CMUN 11
- CMUN 129



You're only four classes away, get started today!

Contact Denise Besson-Silvia at 848-4831 for further information.

**CMUN 8 INTERPERSONAL COMMUNICATION**

This course studies the communication process in an interpersonal (dyadic) setting. This class will explore the ways in which we can improve our communication with others. Verbal and nonverbal messages, self-concept, cultural differences, gender differences, perception, listening and conflict management will be explored.



Section 4195  
MW, 11:10 am - 12:25 pm  
Instructor: Denise Besson-Silvia



Fulfills CSU and UC Oral Communication transfer requirements

The people of old had their own signals. Here's one that has meant "Attention" through all ages.

Sect.	Type	Room	Instructor	Hrs.	Units	Days	Begin-End	Footnotes
-------	------	------	------------	------	-------	------	-----------	-----------

### CMUN 10 Small Group Communication

**Advisory:** Eligible for English 250 and English 260.

**Transferable:** CSU; UC; CSU-GE: A1; IGETC: 1C; GAV-GE: A1; CAN: SPCH 10

An introductory course that develops basic individual reasoning skills, insights and experiences in information-sharing, interacting, decision-making, problem-solving, resolution of disputes and other issues central to group processes.

4196	LEC	MHG11	STAFF		3.00	3.0	TuTh	1030A-1145A	
------	-----	-------	-------	--	------	-----	------	-------------	--

**Above class meets at Morgan Hill Community site**

4197	LEC	TH127	BESSON D		3.00	3.0	MW	1245P-0200P	
------	-----	-------	----------	--	------	-----	----	-------------	--

4198	LEC	TH127	BESSON D		3.00	3.0	M	0210P-0500P	
------	-----	-------	----------	--	------	-----	---	-------------	--

6047	LEC	HOL6	ANDRADE A		3.00	3.0	W	0630P-0920P	
------	-----	------	-----------	--	------	-----	---	-------------	--

**Above class meets at the Hollister Briggs site**

6048	LEC	MHG12	COWAN D		3.00	3.0	W	0630P-0920P	
------	-----	-------	---------	--	------	-----	---	-------------	--

**Above class meets at Morgan Hill Community site**



### CMUN 11 Business Communication

**Prerequisite:** English 250.

**Advisory:** Communication 1A or English 1A.

**Transferable:** CSU

This course will explore business communication contexts by examining organizational cultures, strategic vision and goal setting, leadership managerial roles, and team building communication. Emphasis is placed on analytical and organizational skills, listening, nonverbal and verbal communication, public speaking communication methodology, and domestic and international relations through use of hybrid online and classroom environment for lecture and application.

6049	LEC/online	TH127	WADDELL E		3.00	3.0	M	0630P-0920P	46
------	------------	-------	-----------	--	------	-----	---	-------------	----



**This HYBRID lecture/online class will be delivered partially over the internet. This course will meet 60% in the classroom and 40% online. Come to the campus for the first day of class.**

### CMUN 129 Presentation Graphics - MS Powerpoint

**Advisory:** CSIS 126 or word processing skills in the Windows environment.

**Transferable:** CSU

This introductory course in presentation graphics will use Microsoft Office's "PowerPoint" software to create a computerized presentation with text and objects. This course has the option of a letter grade or credit/no credit. May be repeated three times for credit. This course is also listed as CSIS 129.

4199	LEC	LI120	ANDRADE A		2.00	1.0	MW	1245P-0200P	11
------	-----	-------	-----------	--	------	-----	----	-------------	----

**01/31/05 - 03/14/05**

6050	LEC	MHG5	HAMPTON		4.00	1.0	S	0830A-1220P	11 25
------	-----	------	---------	--	------	-----	---	-------------	-------

**02/04/06 - 03/11/06 Above class meets at Morgan Hill Community site**

6051	LEC	BU111	CONREY J		4.00	1.0	W	0600P-0950P	11 25
------	-----	-------	----------	--	------	-----	---	-------------	-------

**04/05/06 - 05/10/06**

**Computer Art: See ART 48A**

## COMPUTER GRAPHICS AND DESIGN

### CGD 1 Industrial Sketching and Problem Solving

**Advisory:** Eligible for English 250, English 260 and Mathematics 205.

**Transferable:** CSU

Graphical problem solving techniques used by professional designers in various fields of application using both traditional freehand and the computer. Emphasis is on developing the mental ability to visualize objects/shapes and their manipulation. This is an open entry exit supervised class. Students may concurrently enroll in CGD 110 or GCD 2L. May be repeated three times for a total of 8 units.

4172	L/L	LI126	PEACOCK R		4.00	2.0	Tu&3	1110A-1200P	73 99
------	-----	-------	-----------	--	------	-----	------	-------------	-------

### CGD 2 Technical Computer Graphics I

**Advisory:** Satisfactory score on the English placement exam, or a grade of "C" or better in English 250, completion of Mathematics 208, or satisfactory math placement.

**Transferable:** CSU

Foundations of industrial computer graphics with 2D and 3D drawing/modeling and rendering. May be taken concurrently with CGD 110 and CGD 8. This is an open entry/exit course and may be repeated three times for a total of 16 units.

4173	L/L	LI126	PEACOCK R		8.00	4.0	MW&6	0910A-1000A	73 99
------	-----	-------	-----------	--	------	-----	------	-------------	-------

4174	L/L	LI126	PEACOCK R		8.00	4.0	TuTh&6	0910A-1000A	73 99
------	-----	-------	-----------	--	------	-----	--------	-------------	-------

Sect.	Type	Room	Instructor	Hrs.	Units	Days	Begin-End	Footnotes
-------	------	------	------------	------	-------	------	-----------	-----------

### CGD 4 Technical Computer Graphics II

**Advisory:** Satisfactory score on the English placement exam or a grade of C better in English 250, completion of Mathematics 233 or satisfactory Mathematics placement, and completion of CGD 2 with a grade of C or better.

**Transferable:** CSU

Intermediate industrial computer graphics including advanced dimensioning, tolerancing, surface manipulation, geometric intersections, and modeling for solids and rendering. An open entry/exit supervised class which allows for a schedule of varying duration; students work on individual and cooperative group projects. Students may concurrently enroll in CGD 110 and CGD 9.

4175	L/L	LI126	PEACOCK R		8.00	4.0	MW&6	1110A-1200P	73 99
------	-----	-------	-----------	--	------	-----	------	-------------	-------

### CGD 6 Advanced Technical Computer Graphics

**Advisory:** Eligible for English 250, 260 and Mathematics 233.

**Transferable:** CSU

Computer design in precision manufacturing. Applied geometry, mathematics for layout, and tolerancing. Advanced design processes and documentation for the designer. Students may concurrently enroll in CGD 110. An open entry/exit course.

4176	L/L	LI126	PEACOCK R		8.00	4.0	MW&A	1110A-1200P	73 99
------	-----	-------	-----------	--	------	-----	------	-------------	-------

### CGD 8 Advanced Computer Graphics for Design Application I

**Advisory:** Eligible for English 250, 260 and Mathematics 233.

**Transferable:** CSU

Application of computer graphics to specific technical design and graphic communication projects tailored to the student's major study area. An open entry/exit supervised class. This allows students an individual or a cooperative learning environment on selected projects. Students may concurrently enroll in CGD 110.

4177	L/L	LI171	PEACOCK R		8.00	4.0	MW&4	1010A-1100A	73 99
------	-----	-------	-----------	--	------	-----	------	-------------	-------

### CGD 9 Advanced Computer Graphics for Design Application II

**Advisory:** Satisfactory score on the English placement exam or a grade C or better in English 250, completion of Mathematics 233 or satisfactory Mathematics placement. Completion of CGD 2 and CGD 8 with a grade of C or better.

**Transferable:** CSU

A course designed to the student's major study area using computer graphics. The student can combine various content areas for a specific application. An open entry/exit supervised class which allows for a shortened semester schedule with a corresponding increase in lab time. The student is allowed an individual or a cooperative environment on selected projects. Students may concurrently enroll in CGD 110 and CGD 4.

4178	L/L	LI171	PEACOCK R		8.00	4.0	TuTh&4	1010A-1100A	31 73 99
------	-----	-------	-----------	--	------	-----	--------	-------------	----------

### CGD 110 Industrial Graphics Application

**Advisory:** Concurrent enrollment in corresponding computer graphic and design classes.

**Transferable:** CSU

Structured for students concurrently enrolled in computer graphics and art classes. Open entry/exit. Provides an individual or cooperative learning environment on selected projects. A student may elect to enroll for more than the minimal hours of lab for a greater concentration of study and additional credit. May be repeated three times.

4179	LAB	LI126	PEACOCK R		3.00	1.0	TBA	0000-0000	31 73 99
------	-----	-------	-----------	--	------	-----	-----	-----------	----------

4180	LAB	LI126	PEACOCK R		6.00	2.0	TBA	0000-0000	31 73 99
------	-----	-------	-----------	--	------	-----	-----	-----------	----------

4181	LAB	LI126	PEACOCK R		9.00	3.0	TBA	0000-0000	31 73 99
------	-----	-------	-----------	--	------	-----	-----	-----------	----------

4182	LAB	LI126	PEACOCK R		12.00	4.0	TBA	0000-0000	31 73 99
------	-----	-------	-----------	--	-------	-----	-----	-----------	----------

## A counselor's signature is required

if you take 17 or more units (spring or fall) or 5 or more units (summer). You do not need a counselor's signature to register for a class with a prerequisite that was successfully completed at Gavilan.

Sect. Type Room Instructor Hrs. Units Days Begin-End Footnotes

Sect. Type Room Instructor Hrs. Units Days Begin-End Footnotes

**COMPUTER SCIENCE & INFORMATION SYSTEMS****CSIS 1 Computer Literacy - MS Office****Advisory:** Eligible for English 250 and English 260; completion of CSIS 122.**Transferable:** CSU; UC; GAV-GE: E2; CAN: CSCI 2

An introduction to terminology, design, operation for the novice user. Student will gain experience using the Internet for searches and email. They will complete projects using various software including word processing, spreadsheets, database, presentation graphics, and integration. This course has the option of a letter grade or credit/no credit.

4211 LEC	BU120	MILLER K	4.50	2.0	TuTh	0910A-1100A	11
01/24/06 - 03/16/06							

4212 LEC	BU120	MILLER K	4.50	2.0	TuTh	0910A-1100A	11
03/21/06 - 05/25/06							

4213 LEC	HOL3	BRYSON M	6.00	2.0	MW	0930A-1220P	11
01/30/06 - 03/15/06 Above class meets at the Hollister Briggs site							

6052 LEC	HOL3	THOMPSON F	4.00	2.0	Tu	0600P-0950P	11
01/24/06 - 03/21/06 Above class meets at the Hollister Briggs site							

6053 LEC	BU110	VENABLE E	4.00	2.0	W	0600P-0950P	11 96
03/15/06 - 05/17/06							

**CSIS 2 Computers in Business - MS Office****Advisory:** Eligible for Mathematics 233, English 260 and English 250, and CSIS 122**Transferable:** CSU; GAV-GE: E2; CAN: BUS 6

Introduction to computerized business data processing, information management systems, computer hardware, office automation, telecommunications, computer languages, systems analysis and design; hands on experience with common business software packages including word processing, spreadsheets, data base management, presentation graphics as well as systems software and Internet applications. This course has the option of a letter grade or credit/no credit.

4214 L/L	BU120	MILLER K	6.00	4.0	MTuW&2	0945A-1100A	35
----------	-------	----------	------	-----	--------	-------------	----

**CSIS 2L Computers in Business Lab - MS Office****Transferable:** CSU

Computer Lab emphasizing business application in Microsoft Word, Excel, Access, Power Point and Integration. Internet searches are included. This course has the option of a letter grade or credit/no credit. Since supervised repetition and practice enhance skills/proficiencies, This course may be repeated once for credit.

4215 LAB	BU110	BRYSON M	3.00	1.0	Tu&2	0945A-1035A	35
----------	-------	----------	------	-----	------	-------------	----

6054 LAB	BU110	GAFFNEY S	4.00	1.0	Tu	0600P-0950P	11
02/14/06 - 05/16/06							

**CSIS 3 Internet and Information Competency****Advisory:** Eligible for English 250 and 260.**Early Start Class****Transferable:** CSU

Research and evaluation skills using the Internet and other electronic resources, as well as traditional printed materials. This six-week course is also listed as LIB 3. This course has the option of a letter grade or credit/no credit. May be repeated once for credit.

4216	ONLINE	MEADER S	3.00	1.0	TBA	0000-0000	11 25 38
01/03/06 - 02/13/06 This online class will be delivered entirely over the internet. After enrolling, start the class by going to <a href="http://www.gavilan.edu/disted/">http://www.gavilan.edu/disted/</a> , click on your class link, and email the instructor at <a href="mailto:smeader@gavilan.edu">smeader@gavilan.edu</a> . Students who have not begun the class or contacted the instructor by 5 pm on March 11 will be dropped from the class.							

**CSIS 5 C++ Scientific Programming****Prerequisite:** Mathematics 1A**Advisory:** Completion of CSIS 10.**Transferable:** CSU; UC; CAN: CSCI 4

An introduction to computer problem solving and programming using the C++ language for science and engineering majors. Students will write programs for a variety of scientific and mathematical applications. This course has the option of a letter grade or credit/no credit.

6055 L/L	BU111	VANTASSEL D	5.00	3.0	M&1	0600P-0950P	35
----------	-------	-------------	------	-----	-----	-------------	----

**Less Grade Stress!!**

Most CSIS and Business classes can be taken for letter grade or CR/NC. See Credit/No Credit Option Grading.

**CMUN 129***Gilroy and Morgan Hill!***Presentation Graphics - MS Powerpoint**

1 unit - 6 week course

sect. 4199	Andrade A	Mon/Wed	12:45 - 2:00 pm
Dates: 1/31 - 3/14			

sect. 6050	Hampton D	Sat	8:30 am - 12:20 pm
Dates: 2/4 - 3/11 Above class meets at the Morgan Hill site.			

sect. 6051	Conrey J	Wed	6:00 - 9:50 pm
Dates: 4/5 - 5/10			

*Also listed as CSIS 129***Hybrid Lecture/Online Class!****CMUN 11 Business Communication**

Examine organizational cultures, strategic vision and goal setting, leadership managerial roles and team building communication.



6049	TH127	Waddell E	3units	Monday	0630P-0920P
------	-------	-----------	--------	--------	-------------



This HYBRID lecture/online class will be delivered partially over the internet. This course will meet 60% in the classroom and 40% online. Come to the campus for the first day of class.

COMPUTER GRAPHICS and DESIGN

**3-D Modeling & Rendering**

Architecture  
Interior Design  
Industrial design  
3D character design  
Off-road vehicle design  
Comic character design



RHINO/FLAMINGO/  
Bongo/3D studio Max

CGD 2/4  
Technical Computer Graphics I/II

CGD 8/9  
Advanced Computer Graphics  
for Design Application I/II



Sect.	Type	Room	Instructor	Hrs.	Units	Days	Begin-End	Footnotes	Sect.	Type	Room	Instructor	Hrs.	Units	Days	Begin-End	Footnotes
<b>CSIS 6</b>	<b>Web Page Authoring I</b>								<b>CSIS 23</b>	<b>Independent Study</b>							
<b>Advisory:</b> CSIS 1 or CSIS 2 or CSIS 3/LIB 3 advised. <b>Transferable:</b> CSU; GAV-GE: E2									<b>Required:</b> The study outline prepared by the student and the instructor must be filed with the department and the dean. <b>Transferable:</b> CSU								
An introduction to using Hypertext Mark-Up Language (HTML) and Extensible HTML (XHTML) to create web pages which can be updated and displayed on the World Wide Web. Students will use HTML/XHTML to create web pages with text in various sizes and colors, links to other sites, background color or patterns, graphics, tables and mailto links. Principles of design and color as they apply to screen presentations will be included. This course has the option of a letter grade or credit/no credit. May be taken three times for credit. Also listed as LIB 6 and DM 6.									Designed to afford selected students specialized opportunities for exploring areas at the independent study level. The courses may involve extensive library work, research in the community, or special projects. May be repeated until six units of credit are accrued. This course has the option of a letter grade or credit/no credit.								
4217	ONLINE	HOWELL J		4.00	2.0	DHR	0000-0000	11 25 38	4221	IND	MHG8	VANTASSEL D	4.00	1.0	F	0400P-0800P	8
<b>01/03/06 - 03/07/06</b> This early-start online class will be delivered entirely over the internet. After enrolling, start the class by going to <a href="http://www.gavilan.edu/disted/">http://www.gavilan.edu/disted/</a> , click on your class link, and email the instructor at <a href="mailto:jhowell@gavilan.edu">jhowell@gavilan.edu</a> . Students who have not begun the class or contacted the instructor by 5 pm on January 12 will be dropped from the class.									<b>Above class meets at Morgan Hill Community site</b>								
									<b>CSIS 45</b>	<b>C++ Programming I</b>							
<b>Advisory:</b> CSIS 10 or equivalent. Math 205 (Elementary Algebra) <b>Transferable:</b> CSU; UC; GAV-GE: E2; CAN: CSCI 18									<b>Advisory:</b> CSIS 10 or equivalent. Math 205 (Elementary Algebra) <b>Transferable:</b> CSU; UC; GAV-GE: E2; CAN: CSCI 18								
An introduction to the concepts and methods of computer programming using C++. Students will be introduced to procedural and object-oriented programming design methodology. Topics covered include variable and constant declarations, selection statements, repetition, functions and recursion, arrays, strings, pointers, and an introduction to classes and objects. This course will prepare students for the Programming II class. This course has the option of a letter grade or credit/no credit.									An introduction to the concepts and methods of computer programming using C++. Students will be introduced to procedural and object-oriented programming design methodology. Topics covered include variable and constant declarations, selection statements, repetition, functions and recursion, arrays, strings, pointers, and an introduction to classes and objects. This course will prepare students for the Programming II class. This course has the option of a letter grade or credit/no credit.								
4218	ONLINE	HOWELL J		4.00	2.0	DHR	0000-0000	11 25 38	6059	L/L	BU111	VANTASSEL D	6.00	4.0	M&2	0600P-0950P	35
<b>03/06/06 - 05/08/06</b> This online class will be delivered entirely over the internet. After enrolling, start the class by going to <a href="http://www.gavilan.edu/disted/">http://www.gavilan.edu/disted/</a> , click on your class link, and email the instructor at <a href="mailto:jhowell@gavilan.edu">jhowell@gavilan.edu</a> . Students who have not begun the class or contacted the instructor by 5 pm on March 11 will be dropped from the class.									<b>CSIS 46</b>								
									<b>C++ Programming II</b>								
<b>Advisory:</b> CSIS 124 <b>Transferable:</b> CSU; GAV-GE: E2									<b>Advisory:</b> CSIS 45 or CSIS 5, and Mathematics 205. <b>Transferable:</b> CSU; UC								
This course will provide students the opportunity to learn to use the Internet and the World Wide Web. Topics to be covered include history of the Internet and development of the WWW, web browsers, search engines, tools to develop web pages, how to get connected and local Internet providers. This is a credit/no credit course. May be repeated three times for credit.									This course is a continuation of CSIS 45, intended for students majoring in programming and/or planning to transfer to a 4-year college or university Computer Science program. The course will cover topics discussed in CSIS 45 in more detail. In addition the course will cover more advanced C techniques such as pointers, recursion, and linked lists. Special emphasis will be placed on C++ features such as classes, objects, templates and operator overloading. This course has the option of a letter grade or credit/no credit.								
4219	LEC	MHG8	CONREY J	8.00	1.0	TuTh	0910A-0100P	11	5059	L/L	BU111	VANTASSEL D	6.00	4.0	M&2	0600P-0950P	35
<b>05/04/06 - 05/18/06</b> Above class meets at Morgan Hill Community site									<b>CSIS 48</b>								
4220	ONLINE	VENABLE E		3.00	1.0	DHR	0000-0000	11 38	<b>UNIX/Linux Operating System</b>								
<b>03/06/06-04/16/06</b> This online class will be delivered entirely over the internet. After enrolling, start the class by going to <a href="http://www.gavilan.edu/disted/">http://www.gavilan.edu/disted/</a> , click on your class link, and email the instructor at <a href="mailto:evenable@gavilan.edu">evenable@gavilan.edu</a> . Students who have not begun the class or contacted the instructor by 5 pm on January 26 will be dropped from the class.									<b>Advisory:</b> CSIS 1 or CSIS 2 or equivalent computer experience. <b>Transferable:</b> CSU; UC								
									This course will provide the basics of the UNIX/Linux operating system, including the history and the use of UNIX/Linux with hands-on experience using commands and files. Topics to be covered include basic UNIX/Linux commands, text editing, files and directories, electronic mail, pipes and filters, and shell programming. This course has the option of a letter grade or credit/no credit.								
<b>CSIS 9</b>									<b>CSIS 51</b>								
<b>Computer Education for Teachers</b>									<b>Visual Basic .NET Programming</b>								
<b>Advisory:</b> CSIS 122 Computer Keyboarding, or equivalent; English 250 with a grade of C or better. <b>Transferable:</b> CSU									<b>Advisory:</b> CSIS 10 or equivalent. <b>Transferable:</b> CSU; UC; GAV-GE: E2								
The history, uses and development of computers in education. Basic computer skills and terminology will be taught in context of teacher education. Students who successfully complete this course will understand general and specific skills and knowledge required to meet the Technology Standard for Multiple and Single Subject Credential Candidates. This course has the option of a letter grade or credit/no credit. This course is also listed as CD 12.									An introduction to the GUI software applications using Microsoft Visual Basic .NET. This course will give students the opportunity to learn how to create applications using Visual Basic programming in the .NET framework. This course will show the students to use forms, boxes, buttons, labels, menus, scroll bars, and drawing objects. This course will show the students how to develop professional looking and deployable Visual Basic .NET applications. This course has the option of a letter grade or credit/no credit. This course may be repeated three times for credit.								
6056	LEC	MHG8	CLABAUGH D	8.00	3.0	S	0900A-0430P	11 13 25	4222	ONLINE	VANTASSEL D	6.00	4.0	DHR	0000-0000	38 53	
<b>01/28/06 - 03/18/06</b> Above class meets at Morgan Hill Community site									<b>This online class will be delivered entirely over the internet. After enrolling, start the class by going to <a href="http://www.gavilan.edu/disted/">http://www.gavilan.edu/disted/</a>, click on your class link, and email the instructor at <a href="mailto:dvantassel@gavilan.edu">dvantassel@gavilan.edu</a>. Students who have not begun the class or contacted the instructor by 5 pm on January 26 will be dropped from the class.</b>								
									<b>CSIS 18</b>								
<b>UNIX/C++ Programming</b>									<b>CSIS 18L</b>								
<b>Corequisite:</b> CSIS 18L UNIX/C++ Programming Lab <b>Advisory:</b> CSIS 48 UNIX Operating System, CSIS 10 BASIC Programming or other programming experience. <b>Transferable:</b> CSU; UC									<b>Corequisite:</b> CSIS 18 UNIX/C++ Programming <b>Transferable:</b> CSU; UC								
An introduction to the C++ programming language and the UNIX operating system. Topics include programming on a UNIX system, including C/C++ language, shell programming, and the interface between C++ and UNIX. This course has the option of a letter grade or credit/no credit. Concurrent enrollment in CSIS 18L is required.									Supplemental practice in coursework associated with this course is provided. Concurrent enrollment in CSIS 18 is required. This course has the option of a letter grade or credit/no credit.								
6057	LEC	BU111	VANTASSEL D	3.00	3.0	M	0600P-0850P		6058	LAB	BU111	VANTASSEL D	3.00	1.0	M&2	0900P-0950P	35

Sect. Type Room Instructor Hrs. Units Days Begin-End Footnotes

**CSIS 61 Introduction to Geographic Information Systems**

**Advisory:** CSIS 1 or CSIS 2 or equivalent computer experience.  
**Transferable:** CSU, UC

The Geographic Information Systems (GIS) class introduces students to and teaches them how to use desktop GIS software. GIS is a computer-based data-processing tool used to analyze and manage spatial information that combines computers and geography. May be repeated three times for credit. This course has the option of a letter grade or credit/no credit.

6060	L/L	MHG5	PRICE M	6.00	4.0	W&2	0600P-0950P	35
Above class meets at Morgan Hill Community site								

**CSIS 75 PhotoShop I - Adobe PhotoShop**

**Advisory:** CSIS 124 (Windows Fundamentals), CSIS 2L  
**Transferable:** CSU; GAV-GE: C1

This course is based on the software application Adobe PhotoShop. Students learn to scan photographs and manipulate them using Photoshop tool box and special effects filters. They will learn to correct photos; mask image using channels; create duotone, tritone, and quadtone images; prepare photos for use in printing and on the web. This course has the option of a letter grade or credit/no credit. May be repeated three times for credit. Students who repeat this course will learn new and advanced features. This course is also listed as DM 75.

4225	L/L	LI128	BEEDE R	5.00	3.0	TuTh&2	0945A-1100A	25 35
6061	L/L	MHG5	GRZAN R	5.00	3.0	Tu&2	0630P-0920P	8 25 35
Above class meets at Morgan Hill Community site								

**CSIS 77 Introduction to Digital Media and its Tools**

**Advisory:** CSIS 124, CSIS 1, CSIS 2/2L, CSIS 3, or familiarity using the Macintosh or Windows operating system.

**Transferable:** CSU; UC; GAV-GE: C1

An introduction to the field of digital media, including history, social impact, concepts, career options and industry trends. Applying learned visual and aural design principles, students will explore the use of computer-based tools in the design and production of digital media by creating and editing digital images, sounds, video, animation, and text. A comprehensive term project for publication on the web or CD ROM will be required. This course is also listed as ART 77 and DM 77. This course has the option of a letter grade or credit/no credit.

4226	L/L	LI128	BEEDE R	5.00	3.0	TuTh&2	1245P-0200P	25 35
------	-----	-------	---------	------	-----	--------	-------------	-------

**CSIS 80 Digital Photography**

**Advisory:** CSIS 1 or CSIS 2/2L or ART 8A or equivalent computer experience.  
**Transferable:** CSU; UC; GAV-GE: C1

The study of digital photography from digital camera to the computer-based printer or digital media. Artistic, theoretical, and technical aspects will be considered. Topics include information about types and purchasing of digital cameras; theory, mechanics, and art of digital imagery; digital darkroom; eccentricities of digital photo taking; stitching photos for virtual reality; and preparing digital images for print, World Wide Web and other digital media. This course has the option of a letter grade or credit/no credit. This course is also listed as ART 80 and DM 80.

4227	L/L	AR103	EDBERG J	5.00	3.0	M	1245P-0315P	25 95
		LI128	EDBERG J			M	0210P-0325P	

**CSIS 84 JavaScript Programming**

**Advisory:** CSIS 7  
**Transferable:** CSU; UC

Fundamentals of JavaScript client-side programming for Web pages requiring data collection or other user interaction. Students will create Web pages that execute on the client (personal system) using JavaScript. This course may be repeated one time for credit. This course has the option of a letter grade or credit/no credit.

4228	ONLINE	VENABLE E		2.00	2.0	DHR	0000-0000	11 38
------	--------	-----------	--	------	-----	-----	-----------	-------



**03/06/06 - 05/19/06** This online class will be delivered entirely over the internet. After enrolling, start the class by going to <http://www.gavilan.edu/disted/>, click on your class link, and email the instructor at [evenable@gavilan.edu](mailto:evenable@gavilan.edu). Students who have not begun the class or contacted the instructor by 5 pm on March 11 will be dropped from the class.

**Don't go to the wrong city!**

MHG = Morgan Hill Community Center site

HOL = Hollister Briggs site

Sect. Type Room Instructor Hrs. Units Days Begin-End Footnotes

**CSIS 48 UNIX/Linux****Operating System**

basic UNIX/Linux commands, text editing, files and directories, electronic pipes and filters

Section 4223

This class will be taught online.



Learn to scan, correct and manipulate photos with  
**Adobe Photoshop CS**

**UPGRADED!** CSIS 75 – Photoshop I

Sign Up Now!

**BUSINESS/CSIS DEGREES AND CERTIFICATES**

General Business  
 General Office  
 Accounting  
 Medical Office  
 Business Economics  
 Computer Networking  
 UNIX Operating Systems  
 Programming for the Internet  
 Business Computer Applications  
 Scientific Programming  
 Computer Programming



Consult the Gavilan Catalog for complete information or visit the website at [www.gavilan.edu](http://www.gavilan.edu)

**Are you a parent?**

Child care is available while you are in class.

**(408) 848-4815**  
 NAEYC accredited

Gavilan College  
**Child Development Center**

Sect.	Type	Room	Instructor	Hrs.	Units	Days	Begin-End	Footnotes
-------	------	------	------------	------	-------	------	-----------	-----------

### CSIS 85 Web Design I: Dreamweaver

**Advisory:** CSIS 6 or basic knowledge of HTML.

**Transferable:** CSU; GAV-GE: C1

Basic and intermediate principles of designing Web pages/sites using the Dreamweaver web design software and HTML. Emphasis will be on good design and the use of tables, frames, forms, rollovers, DHTML, XHTML, behaviors, and CSS. Also includes site maintenance and the integration of multimedia components such as graphics, sound, animation, and video. This course is for the content person to design, develop, and maintain effective Web sites. This course is also listed as ART 85 and DM 85. This course has the option of a grade or credit/no credit. May be repeated twice for credit.

4229	LEC	BU111	THOMPSON F	4.00	2.0	F	0900A-1250P	11 25
<b>03/10/06 - 05/19/06</b>								

### CSIS 107 Digital Media Design

**Advisory:** CSIS 1 or CSIS 2/2L or equivalent computer experience

**Transferable:** CSU

Fundamentals of design for visual, time-based, interactive, and sound arts as applied to digital media. Includes basic storytelling, graphic design, information architecture, and human factors. Page layout, scripting, storyboards, and flow charts will be used as tools applicable to the design and development of business presentations, interactive media, educational multimedia, animation, web sites, video games, and film/video. This course has the option of a letter grade or credit/no credit. Also listed as ART 107 and DM 107.

4230	L/L	L1128	BEEDER	3.00	2.0	W	1245P-0300P	25
------	-----	-------	--------	------	-----	---	-------------	----

### CSIS 108 Digital Media Lab

**Advisory:** CSIS 1 or CSIS 2/2L or equivalent computer experience.

**Transferable:** CSU

Supervised practice and individualized computer assisted learning of software applications and techniques commonly found in the design and production of digital media (e.g., digital art and imaging, digital photography, digital print, digital audio/video, web design/authoring, DVD/CD ROMs, animation). Supplements lecture courses. Open entry/exit, so may be added at anytime during the semester. Graded credit/no credit only. May be repeated three times for credit. Also listed as ART 108 and DM 108.

4231	LAB	L1128	BEEDER BEEDER	1.50	.5	M W	1110A-0150P 1110A-1215P	25 31
<b>01/30/06 - 05/22/06</b>								

4232	LAB	L1128	EDBERG J	2.00	.5	M	0330P-0520P	25 31
------	-----	-------	----------	------	----	---	-------------	-------

### CSIS 113 Introduction to Digital Video

**Advisory:** CSIS 1 or CSIS 2/2L or equivalent computer experience

**Transferable:** CSU

Introduction to the aesthetic and technical aspects of digital video recording, non-linear editing, special effect generation, and production of video (and associated audio) using the personal computer equipped with specialized software such as iMovie, Final Cut Pro, and After Effects. Also considered will be the preparation of digital video for use in interactive media such as CD, DVD, and the World Wide Web. Students will produce a final digital video project on DVD. This course has the option of a letter grade or credit/no credit. May be repeated 2 times for credit. Also listed as ART 113 and DM 113.

4233	L/L	L1128	BEEDER	5.00	3.0	MW	0945A-1100A	25 35
------	-----	-------	--------	------	-----	----	-------------	-------

### CSIS 114 Digital Media Production

**Advisory:** At least one of the following: ART 75, CGE 2, JOUR 18A, MUS 21, CSIS 7, CSIS 71, OR CSIS 77. or possess equivalent skills from any one of the following areas: digital media, computer graphics, digital print, film, TV/video, journalism (publishing), drawing or illustration, web design/development, business/marketing, or programming.

**Transferable:** CSU

A team oriented practicum that focuses on the application of learned skills to the production of digital media and digital print projects, such as web sites, CD ROM, and DVDs. Project development will be accomplished according to team derived master schedules. Lectures will be on project management, work coordination and production techniques, client-team interface, asset management and integration, budget estimates, testing, and copyright infringement. Please note that this is very much a team oriented class. This course has the option of a letter grade or credit/no credit. This course is also listed as ART 114 and DM 114.

4234	LEC	L1128	BEEDER	2.00	2.0	M	1110A-0100P	25
------	-----	-------	--------	------	-----	---	-------------	----

Sect.	Type	Room	Instructor	Hrs.	Units	Days	Begin-End	Footnotes
-------	------	------	------------	------	-------	------	-----------	-----------

### CSIS 120 Computerized Accounting - QuickBooks

**Advisory:** CSIS 1 or CSIS 2 or the equivalent computer experience. ACCT 20 or ACCT 101 or ACCT 103 or ACCT 105 or the equivalent accounting experience.

**Transferable:** CSU

An introduction to computer assisted accounting. Hands-on use of a microcomputer menu-driven accounting package to do general ledger, sales journal, cash receipts journal, cash payments journal, purchases journal, payroll, receivables, payables and related financial reports. This course has the option of a letter grade or credit/no credit. Repeatable whenever a new software package is adopted. This course is also listed as ACCT 120.

6062	L/L	MHG5	BARTA M	4.00	2.0	Th&1	0630P-0920P	25 35 96
<b>Above class meets at Morgan Hill Community site</b>								

### CSIS 121 Spreadsheet - MS Excel

**Advisory:** CSIS 1 or CSIS 2 or equivalent computer experience.

**Transferable:** CSU

Introduction to the computer spreadsheet software. A hands-on approach to learning terms, commands, and applications of a spreadsheet program. This course will help prepare students for taking the Excel MOUS (Microsoft Office User Specialist) exams. This course has the option of a letter grade or credit/no credit and may be repeated for credit when the software changes.

6063	LEC	HOL3	LITTIG A	4.00	2.0	Th	0600P-0950P	11
<b>01/26/06 - 03/23/06 Above class meets at the Hollister Briggs site</b>								

6064	L/L	MHG5	HAMPTON	4.00	2.0	S	0830A-1220P	11
<b>03/18/06 - 05/20/06 Above class meets at Morgan Hill Community site</b>								

### CSIS 122 Computer Keyboarding

**Transferable:** CSU

A self-paced course for students who wish to master the alphabetic and numeric keyboard on the computer. This course is designed for students who do not know the alphabetic keyboard by "touch" and for those who want to improve their ability to type straight copy with increased speed and accuracy. The course provides "hands-on" instruction to help students reach optimum computer keyboarding skills within a limited time. This is a credit/no credit course. Course may be repeated until 3 units are accrued.

4235	LAB	BU110	GAFFNEY S	1.50	.5	Day/Time	see instructor	7 9
------	-----	-------	-----------	------	----	----------	----------------	-----

4236	LAB	BU110	GAFFNEY S	3.00	1.0	Day/Time	see instructor	7 9
------	-----	-------	-----------	------	-----	----------	----------------	-----

4237	LAB	MHG8	CONREY J	2.00	.5	TuTh	1010A-1200P	
------	-----	------	----------	------	----	------	-------------	--

**02/28/06 - 05/18/06 Above class meets at Morgan Hill Community site**

4238	LAB	HOL3	BRYSON M	1.50	.5	MW	1010A-1200P	
------	-----	------	----------	------	----	----	-------------	--

**Above class meets at the Hollister Briggs site**

4239	LAB	HOL3	BRYSON M	3.00	1.0	MW	1010A-1200P	
------	-----	------	----------	------	-----	----	-------------	--

**02/01/06 - 05/03/06 Above class meets at the Hollister Briggs site**

4240	LAB	MHG8	CONREY J	3.00	1.0	TuTh	1010A-1200P	
------	-----	------	----------	------	-----	------	-------------	--

**02/28/06 - 05/18/06 Above class meets at Morgan Hill Community site**

6065	LAB	HOL3	HAMPTON	3.00	1.0	M	0600P-0850P	
------	-----	------	---------	------	-----	---	-------------	--

**Above class meets at the Hollister Briggs site**

6066	LAB	HOL3	HAMPTON	1.50	.5	M	0600P-0850P	
------	-----	------	---------	------	----	---	-------------	--

**Above class meets at the Hollister Briggs site**

6067	LAB	BU110	GAFFNEY S	1.50	.5	Tu	0600P-0850P	7 9
------	-----	-------	-----------	------	----	----	-------------	-----

6068	LAB	BU110	GAFFNEY S	3.00	1.0	Tu	0600P-0850P	7 9
------	-----	-------	-----------	------	-----	----	-------------	-----

### CSIS 124 Windows Fundamentals

**Advisory:** Basic keyboarding skill.

**Transferable:** CSU

This course provides fundamental information on the Windows environment for the computer. Introductory Windows operations and file management are covered. This is a credit/no credit course. This course may be repeated three times for credit.

4241	LEC	HOL3	BRYSON M	8.00	1.0	MW	0910A-0100P	11
------	-----	------	----------	------	-----	----	-------------	----

**03/20/06 - 04/03/06 Above class meets at the Hollister Briggs site**

4242	LEC	MHG8	CONREY J	8.00	1.0	TuTh	0910A-0100P	11
------	-----	------	----------	------	-----	------	-------------	----

**03/09/06 - 03/23/06 Above class meets at Morgan Hill Community site**

4243	LEC	BU111	MILARE	4.00	1.0	M	1010A-0200P	11
------	-----	-------	--------	------	-----	---	-------------	----

**01/30/06 - 03/06/06**

6069	LEC	HOL3	THOMPSON F	4.00	1.0	W	0600P-0950P	11
------	-----	------	------------	------	-----	---	-------------	----

**02/08/06 - 03/08/06 Above class meets at the Hollister Briggs site**

## The Final Word!

Look for the Final Exams schedule on page 110 of this schedule.

Sect.	Type	Room	Instructor	Hrs.	Units	Days	Begin-End	Footnotes
-------	------	------	------------	------	-------	------	-----------	-----------

**CSIS 126 Word Processing - MS Word****Advisory:** Eligible for English 260 and basic keyboarding skills.**Transferable:** CSU

This introductory course for word processing with Windows is designed for business and non-business majors. Students will develop word processing skills to create a document, select and edit text, move and copy text, use the spelling, grammar, and thesaurus features, format text, and create headers, footnotes for a research paper. This course has the option of a letter grade or credit/no credit and may be repeated when the software changes.

4244	LEC	MHG8	CONREY J	8.00	2.0	TuTh	0910A-0100P	11
<b>03/28/06 - 05/02/06 Above class meets at Morgan Hill Community site</b>								
4245	LEC	BU111	MILARE	4.00	2.0	M	1010A-0200P	11
<b>03/13/06 - 05/15/06</b>								
4246	LEC	HOL3	BRYSON M	8.00	2.0	MW	0910A-0100P	11
<b>04/05/06 - 05/10/06 Above class meets at the Hollister Briggs site</b>								
6070	LEC	HOL3	THOMPSON F	4.00	2.0	W	0600P-0950P	11
<b>03/15/06 - 05/17/06 Above class meets at the Hollister Briggs site</b>								

**CSIS 128 Database - MS Access****Advisory:** CSIS 1 or CSIS 2 or equivalent knowledge.**Transferable:** CSU

Introduction to Microsoft Access, a relational database management software tool. Students will learn to create and manage a database. This course will help prepare students for taking the Access MOUS (Microsoft Office User Specialist) exams. May be repeated three times for credit. This course has the option of a letter grade or credit/no credit.

6071	L/L	MHG8	CONREY J	4.00	2.0	W	0600P-0950P	11
<b>02/01/06 - 03/29/06 Above class meets at Morgan Hill Community site</b>								

**CSIS 129 Presentation Graphics - MS PowerPoint****Advisory:** CSIS 126 or word processing skills in the Windows environment.**Transferable:** CSU

This introductory course in presentation graphics will use Microsoft Office's "PowerPoint" software to create a computerized presentation (slide show) with text and objects. This course is also listed as CMUN 129. This course has the option of a letter grade or credit/no credit. May be repeated three times for credit.

4247	LEC	LH20	ANDRADE A	1.00	1.0	MW	1245P-0200P	
6072	LEC	MHG5	HAMPTON	4.00	1.0	S	0830A-1220P	11 25
<b>02/04/06 - 03/11/06 Above class meets at Morgan Hill Community site</b>								
6073	LEC	BU111	CONREY J	4.00	1.0	W	0600P-0950P	11 25
<b>04/05/06 - 05/10/06</b>								

**CSIS 132 Intermediate Word Processing - MS Word****Advisory:** CSIS 126 Word Processing - MS Word**Transferable:** CSU

This course covers formatting with macros and styles, mail merge techniques, sorting data in tables, preparing and protecting forms. These techniques will be applied to a variety of different documents: contracts, reports, surveys, manuscripts, and various types of letters. Other topics include working with shared documents in a workgroup, integrating applications and creating hyperlinks for workgroup settings using Microsoft Word. This course has the option of a letter grade or credit/no credit.

4249	LEC	BU111	CONREY J	2.00	2.0	W	1100A-0200P	11 20
<b>02/08/06 - 04/26/06</b>								

**CSIS 140 Basic Digital Film/Video Production****Transferable:** CSU; UC

An on-line self-paced course covering the basics of film/video production and post production (editing) using "easy to use" computer software such as Apple's iMovie. Beneficial for students who are producing a video/film project as a requirement for another college course, extra skills development, or for self interest. Completion of the associated class or personal project in DVD format using either personal video equipment or the equipment in the Digital Media Studio is required. May be repeated twice for credit. This course has the option of a letter grade or credit/no credit. This course is also listed as ART 140 and DM 140.

4250	ONLINE	BEEDE R		1.00	1.0	DHR	0000-0000	25 38
------	--------	---------	--	------	-----	-----	-----------	-------

**This online class will be delivered entirely over the internet. After enrolling, start the class by going to <http://www.gavilan.edu/disted/>, click on your class link, and email the instructor at [rbeede@gavilan.edu](mailto:rbeede@gavilan.edu). Students who have not begun the class or contacted the instructor by 5 pm on January 26 will be dropped from the class.**



Sect.	Type	Room	Instructor	Hrs.	Units	Days	Begin-End	Footnotes
-------	------	------	------------	------	-------	------	-----------	-----------

**UPGRADED SOFTWARE!**

**Dreamweaver MX2004****CSIS 85 - Web Design I: Dreamweaver**

In this course you will learn to design, develop, and maintain effective Web sites.

*DESIGN YOUR OWN WEB SITE!*

**This course is also listed as ART 85 and DM 85.**

Sect. 4229	Fri	9:00 am- 12:50 pm	BU111	3/10-5/19
------------	-----	-------------------	-------	-----------

**Microsoft® Office<sup>xp</sup>****UPDATED Software Applications offered this semester**

CSIS 1	Computer Literacy - MS Office Overview
CSIS 2L	Computers in Business Lab - MS Office
CSIS 121	Spreadsheet - MS Excel
CSIS 126	Word Processing - MS Word
CSIS 129	Presentation Graphics - MS PowerPoint

**Register now and become an Office XP power user!**

**LEARN TO BUILD AND MAINTAIN COMPUTERS**

SUPPORT YOURSELF AND OTHERS WITH:

- CSIS 181, PC HARDWARE
- CSIS 182, OPERATING SYSTEMS

PREPARATION FOR A+ CERTIFICATION EXAMS  
(Get discounts on Exams)



**New Class**

Continue to develop your MS Word skills!

**CSIS 132 Intermediate Word Processing**

In this class you will learn to:

- Format with macros and styles
- Do mail merging
- Sort data in tables
- Prepare and protect forms



You will apply these techniques to different types of documents: contracts, reports, surveys, manuscripts, and letters.

<b>Sect. 4249</b>	Wed.	11 am-2 pm	BU111	2/8-4/26
-------------------	------	------------	-------	----------



Sect.	Type	Room	Instructor	Hrs.	Units	Days	Begin-End	Footnotes
-------	------	------	------------	------	-------	------	-----------	-----------

### CSIS 175B Router Theory and Router Technologies

**Prerequisite:** CSIS 175A

**Advisory:** CSIS 48

**Transferable:** CSU

This course is the second of four courses in the Cisco Networking Academy curriculum. This course is an introduction to router concepts and terminology including Ethernet and Token Ring frames, RIP and IGRP routing protocols, distance vector and link state routing, routing loop issues, TCP/IP basics, IP addressing, and IP access lists. Students will get hands-on experience configuring Cisco routers. This course has the option of a letter grade or credit/no credit.

4251	ONLINE	VENABLE E		4.00	4.0	DHR	0000-0000	38 55
------	--------	-----------	--	------	-----	-----	-----------	-------



**This online class will be delivered entirely over the internet. After enrolling, start the class by going to <http://www.gavilan.edu/disted/>, click on your class link, and email the instructor at [evenable@gavilan.edu](mailto:evenable@gavilan.edu). Students who have not begun the class or contacted the instructor by 5 pm on January 26 will be dropped from the class.**

### CSIS 175C Advanced Routing/Switching/WAN

**Prerequisite:** CSIS 175B

**Transferable:** CSU

This course is the third/last course in the Cisco Networking Academy curriculum. This course covers the advanced features of router and routing concepts including IPX access lists, LAN segmentation, network congestion issues, cut-through and store and forward switches, and the operation of the Spanning Tree protocol. Other topics include: Wide Area Network services including LAPB, Frame Relay, ISDN, HDLC, PPP, DDR, LMI's and maps and subinterfaces on the Cisco router. This class includes practice using the Cisco routers. This course has the option of a letter grade or credit/no credit.

4252	ONLINE	VENABLE E		4.00	4.0	DHR	0000-0000	38 55
------	--------	-----------	--	------	-----	-----	-----------	-------



**This online class will be delivered entirely over the internet. After enrolling, start the class by going to <http://www.gavilan.edu/disted/>, click on your class link, and email the instructor at [evenable@gavilan.edu](mailto:evenable@gavilan.edu). Students who have not begun the class or contacted the instructor by 5 pm on January 26 will be dropped from the class.**

### CSIS 181 PC Hardware

**Advisory:** CSIS 124, CSIS 1 OR CSIS 2, or equivalent computer experience.

**Transferable:** CSU

This course examines computing hardware, operating systems, and software applications from a technical side to enable students to select, install, maintain and optimize a computer system. This course will help prepare students to pursue the A+ Hardware Certification. This course has the option of a letter grade or credit/no credit.

6075	L/L	BU120	ROBINSON V	6.00	4.0	Tu&2	0600P-0950P	35 96
------	-----	-------	------------	------	-----	------	-------------	-------

### CSIS 182 Operating Systems

**Advisory:** CSIS 1 or CSIS 2 or equivalent computer experience

**Transferable:** CSU

This course will survey current computer operating systems such as Microsoft Windows 98, NT, 2000 and XP. Linux will also be covered. Topics include file system management, systems requirements, network systems integration, security, and regular maintenance procedures. This course has the option of a letter grade or credit/no credit.

6076	L/L	BU118	ROBINSON V	6.00	4.0	Th&2	0600P-0950P	35 96
------	-----	-------	------------	------	-----	------	-------------	-------

### CSIS 190 Occupational Work Experience/Computer Science

**Required:** Declared vocational major. Concurrent enrollment in seven or more units (including CWE units, except for summer school. For summer school, enrollment in one other class is required). Minimum 2.00 G.P.A.

**Transferable:** CSU

College credit for learning experience obtained on the job in accordance with a training plan developed cooperatively between the employer, college and student. 75 hours per semester per unit or 60 hours per semester for unpaid experience. This is a credit/no credit course. May be taken for a maximum of 16 work experience units.

4253	WEX	SC154S	KERRL	5.00	1.0	DHR	0000-0000	16
4254	WEX	SC154S	KERRL	10.00	2.0	DHR	0000-0000	16
4255	WEX	SC154S	KERRL	15.00	3.0	DHR	0000-0000	16
4256	WEX	SC154S	KERRL	20.00	4.0	DHR	0000-0000	16

## TBA

means that the class has a flexible schedule. For details, contact the instructor.

Sect.	Type	Room	Instructor	Hrs.	Units	Days	Begin-End	Footnotes
-------	------	------	------------	------	-------	------	-----------	-----------

### CSIS 570 Computer Access Evaluation

**Advisory:** This course is intended for students with a verified disability who show a need for the use of adaptive computer programs and/or equipment or demonstrated academic deficit.

**Transferable:** No

This course is intended to provide for in-depth computer access evaluation in order to determine an appropriate access environment for a student with a disability or multiple disabilities. This is a credit/no credit course. May be repeated as necessary based on measurable progress as documented in the student's Individual Education Plan or Student Educational Contract. This is an open entry, open exit course.

4257	LAB	LI105	MARINGER J	1.50	.5	Day/Time -	see instructor	74 75
------	-----	-------	------------	------	----	------------	----------------	-------

### CSIS 571 Computer Assisted Instruction

**Advisory:** This course is intended for students with a verified disability who show a need for the use of adaptive computer programs and/or equipment or demonstrated academic deficit.

**Transferable:** No

This course is an Assistive Computer Technology Lab designed for students who are eligible for Disabled Student Services. The course is designed to improve basic academic skills and/or cognitive processes through the use of appropriate software or to learn assistive devices designed to make computer accessible. Course content is based on individual educational plans which are developed for each student. This is a credit/no credit course. May be repeated as necessary based on measurable progress as documented in the student's Individual Education Plan or Student Educational Contract. This is an open entry, open exit course.

4258	LAB	LI105	MARINGER J	1.50	.5	Day/Time -	see instructor	74 75
------	-----	-------	------------	------	----	------------	----------------	-------

4259	LAB	LI105	MARINGER J	3.00	1.0	Day/Time -	see instructor	74 75
------	-----	-------	------------	------	-----	------------	----------------	-------

4260	LAB	LI105	MARINGER J	6.00	2.0	Day/Time -	see instructor	74 75
------	-----	-------	------------	------	-----	------------	----------------	-------

### CSIS 572 Adaptive Computer Basics

**Advisory:** This course is intended for students with a verified disability who show a need for the use of adaptive computer programs and/or equipment.

**Transferable:** No

This course will include an introduction to the basic concept of how computers work, using the computer keyboard, word processing, computer ethics and presentation graphics. This course will be self-paced and adjusted so that students with learning, physical, or communicative disabilities can learn a number of adaptive devices designed to make computers accessible. This is a credit/no credit course. May be repeated as necessary based on measurable progress as documented in the student's Individual Education Plan or Student Educational Contract. This is an open entry, open exit course.

4261	L/L	LI105	MARINGER J	3.00	1.0	MW&1	0110P-0200P	74 75
------	-----	-------	------------	------	-----	------	-------------	-------

## Computerized Accounting: See ACCT 120

## COSMETOLOGY

### COS 200 Beginning Cosmetology

**Advisory:** Eligible for English 250, 260 and Mathematics 205.

**Transferable:** No

Fundamental principles of the science/art of beauty culture including hair design, chemical services and cosmetic therapy.

4200	L/L	CO102	RAMIREZ G	25.00	12.0	TuWTh	0910A-1000A	27 29
		CO102	GOMEZ D			TuWThF	1010A-0345P	
		BU118	RAMIREZ G			F	0910A-1000A	

### COS 201 Intermediate Cosmetology

**Advisory:** Satisfactory completion of Cosmetology 200. Eligible for English 250, 260 and Mathematics 205.

**Transferable:** No

Extended studies and techniques in tinting, bleaching, permanent waving, shaping, styling, acrylic nail, pedicuring, chemical straightening, soft perming, waxing, care of skin and make-up.

4201	L/L	CO102	HERNANDEZ R	25.00	12.0	TuWThF	0910A-0345P	27
------	-----	-------	-------------	-------	------	--------	-------------	----

### COS 202 Advanced Cosmetology

**Prerequisite:** Completion of COS 200 & 201.

**Advisory:** Eligible for English 250, 260 and Mathematics 205.

**Transferable:** No

Advanced techniques in tinting, lightening, hair design and cosmetic chemistry.

4202	L/L	CO102	KHANNA N	25.00	12.0	TuWThF	0910A-0345P	27
------	-----	-------	----------	-------	------	--------	-------------	----

Sect. Type Room Instructor Hrs. Units Days Begin-End Footnotes

**COS 203 Practicum**

**Prerequisite:** Completion of COS 200, 201 and 202.  
**Advisory:** Eligible for English 250, 260 and Mathematics 205.  
**Transferable:** No

Advanced techniques in tinting, lightening, hair and design and cosmetic chemistry.

4203	L/L	CO102	KHANNA N	8.00	4.0	TuWThF	0910A-0345P	27
4204	L/L	CO102	KHANNA N	20.00	6.0	TuWThF	0910A-0345P	27
4205	L/L	CO102	ANDRE M	25.00	12.0	TuWThF	0910A-0345P	27
		HU105	ANDRE M			Tu	0100P-0345P	
4206	L/L	CO102	ANDRE M	4.00	2.0	TuWThF	0910A-0345P	
4207	L/L	CO102	ANDRE M	20.80	10.0	TuWThF	0910A-0345P	27
4208	L/L	CO102	KHANNA N	16.60	8.0	TuWThF	0910A-0345P	

**COS 205 State Board Review**

**Advisory:** Cosmetology 201.  
**Transferable:** No  
 State Board exam procedures and standards.

4209	LAB	CO102	HERNANDEZ R	5.00	2.0	M	0910A-0200P	
------	-----	-------	-------------	------	-----	---	-------------	--

**COS 290 Occupational Work Experience/ Cosmetology**

**Required:** Declared vocational major. Concurrent enrollment in seven or more units (including CWE units, except for summer school. For summer school, enrollment in one other class is required). Minimum 2.00 G.P.A.

**Transferable:** No  
 College credit for learning experience obtained on the job in accordance with a training plan developed cooperatively between the employer, college and student. 75 hours per semester per unit or 60 hours per semester for unpaid experience. This is a credit/no credit course. May be taken for a maximum of 16 work experience units.

4210	WEX	SC154S	KERR L	3.00	1.0	DHR	0000-0000	16
------	-----	--------	--------	------	-----	-----	-----------	----

**CPR: See Allied Health**

**Desktop Publishing: See CSIS**

**DIGITAL MEDIA**

**DM 6 Web Page Authoring I**

**Advisory:** CSIS 1 or CSIS 2 or CSIS 3/LIB 3 advised.  
**Transferable:** CSU; GAV-GE: E2

An introduction to using Hypertext Mark-Up Language (HTML) and Extensible HTML (XHTML) to create web pages which can be uploaded and displayed on the World Wide Web. Students will use HTML/XHTML to create web pages with text in various sizes and colors, links to other sites, background color or patterns, graphics, tables and mailto links. Principles of design and color as they apply to screen presentations will be included. This course has the option of a letter grade or credit/no credit. May be taken three times for credit. Also listed as CSIS 6 and LIB 6.

4269 ONLINE HOWELL J 4.00 2.0 DHR 0000-0000 11 25 38  
**01/03/06 - 03/07/06** This early-start online class will be delivered entirely over the internet. After enrolling, start the class by going to <http://www.gavilan.edu/disted/>, click on your class link, and email the instructor at [jhowell@gavilan.edu](mailto:jhowell@gavilan.edu). Students who have not begun the class or contacted the instructor by 5 pm on January 12 will be dropped from the class.

4270 ONLINE HOWELL J 4.00 2.0 DHR 0000-0000 11 25 38  
**03/06/06 - 05/08/06** This online class will be delivered entirely over the internet. After enrolling, start the class by going to <http://www.gavilan.edu/disted/>, click on your class link, and email the instructor at [jhowell@gavilan.edu](mailto:jhowell@gavilan.edu). Students who have not begun the class or contacted the instructor by 5 pm on March 11 will be dropped from the class.

**DM 23 Independent Study**

**Required:** The study outline prepared by the student and the instructor must be filed with the department and the dean.  
**Transferable:** CSU  
 Designed to afford selected students specialized opportunities for exploring areas at the independent study level. The courses may involve extensive library work, research in the community, or special projects. May be repeated until six units of credit are accrued. This course has the option of a letter grade or credit/no credit.

4272	IND	LI128	BEEDER	2.00	2.0	DHR	0000-0000	
------	-----	-------	--------	------	-----	-----	-----------	--

Sect. Type Room Instructor Hrs. Units Days Begin-End Footnotes

**STUDENT Profile**

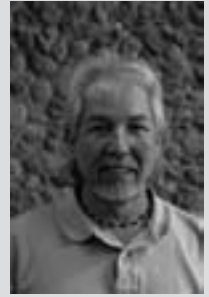

**JESSE SANDOW:**

After a 4 year stint with the U.S. Navy and 29 years of service with the U.S. Postal Service, I returned to Gavilan to pursue a degree in Liberal Studies. Soon I will transfer to a UC or a CSU where I will continue my studies in Public Policy. I currently serve as the Gavilan College Student Trustee and as a writing assistant in the Writing Center. I am also a member of the Rhu Alpha Mu honor society, the Trio Program and M.A.N.O. (Men's Academic Network Organization).

I was studying abroad this summer in Malaga, Spain with the Gavilan College Spanish Immersion Program. This experience gave me an opportunity to live my passion of living life to the fullest and fulfilling my needs to be a life long learner. I want to live a meaningful life with a purpose of giving back to my community.

**Day of Beauty**

for Men & Women

- Includes:
- ✓ Hair cut & style
  - ✓ Deep conditioning
  - ✓ Scalp treatment
  - ✓ Manicure
  - ✓ Facial
  - ✓ Eyebrow arch
  - ✓ Makeup



only \$30

w/o coupon - \$35

**DISCOUNTS**  
 Senior Citizens: 20% daily  
 Staff/Students: 10% daily  
 Discounts not applicable to DAILY SPECIALS, Special perms or any service under \$5

**Spring/Fall hours**  
 Wed.-Fri. 10:30 am - 2:30 pm  
**Summer hours**  
 Tu.-Th. 10:30 am - 3:30 pm

<b>DAILY SPECIALS</b>	<b>Wednesday:</b> Hair Cut ONLY - \$5 Hair Cut & Style - \$9 Hair Color - 20% off	<b>Thursday/Friday:</b> All Basic Perms - 20% off Plain Manicure & Pedicure - \$11
-----------------------	--	--

All work performed by students supervised by instructors  
 Discounts not applicable to daily specials, special color, special perms or any service under \$6. Not valid with any other discounts.

For appointments call 408-842-5055

Sect.	Type	Room	Instructor	Hrs.	Units	Days	Begin-End	Footnotes
-------	------	------	------------	------	-------	------	-----------	-----------

**DM 60 3D Animation I**

**Advisory:** Any of the following: DM 77, DM 75, DM 76, DM 110, CGD 2, ART 48A, ART 48B, or equivalent.

**Transferable:** CSU

Fundamentals and aesthetics of digital 3D animation, including modeling, animation and rendering. Focus on computer animation tools and techniques including workflow and storyboarding. Builds a solid foundation for developing character animation, architecture walkthroughs, and special-effect sequences. This course has the option of a letter grade or credit/no credit.

4273	L/L	LI126	PEACOCK R	5.00	3.0	W&2	1245P-0300P	20 35
------	-----	-------	-----------	------	-----	-----	-------------	-------

**DM 61 3D Animation II**

**Advisory:** DM 60 or equivalent experience.

**Transferable:** CSU

This class extends animation into character modeling, soundtrack synchronization, advanced shading, lighting, rendering and compositing techniques. May include topics such as particles, dynamics, and scripting. This course has the option of a letter grade or credit/no credit.

4274	L/L	LI126	PEACOCK R	5.00	3.0	W&2	1245P-0300P	35
------	-----	-------	-----------	------	-----	-----	-------------	----

**DM 75 PhotoShop I - Adobe PhotoShop**

**Advisory:** CSIS 124 (Windows Fundamentals), CSIS 2L

**Transferable:** CSU; GAV-GE: C1

This course is based on the software application Adobe PhotoShop. Students learn to scan photographs and manipulate them using Photoshop tool box and special effects filters. They will learn to correct photos; mask image using channels; create duotone, tritone, and quadtone images; prepare photos for use in printing and on the web. This course has the option of a letter grade or credit/no credit. May be repeated three times for credit. Students who repeat this course will learn new and advanced features. This course is also listed as CSIS 75.

4275	L/L	LI128	BEEDER	5.00	3.0	TuTh&2	0945A-1100A	25 35
------	-----	-------	--------	------	-----	--------	-------------	-------

6077	L/L	MHG5	GRZAN R	5.00	3.0	Tu&2	0630P-0920P	8 25 35
------	-----	------	---------	------	-----	------	-------------	---------

**Above class meets at Morgan Hill Community site**

**DM 77 Introduction to Digital Media and its Tools**

**Advisory:** CSIS 124, CSIS 1, CSIS 2/2L, CSIS 3, or familiarity using the Macintosh or Windows operating system.

**Transferable:** CSU; UC; GAV-GE: C1

An introduction to the field of digital media, including history, social impact, concepts, career options and industry trends. Applying learned visual and aural design principles, students will explore the use of computer-based tools in the design and production of digital media by creating and editing digital images, sounds, video, animation, and text. A comprehensive term project for publication on the web or CD ROM will be required. This course is also listed as ART 77 and CSIS 77. This course has the option of a letter grade or credit/no credit.

4276	L/L	LI128	BEEDER	5.00	3.0	TuTh&2	1245P-0200P	25 35
------	-----	-------	--------	------	-----	--------	-------------	-------

**DM 80 Digital Photography**

**Advisory:** CSIS 1 or CSIS 2/2L or ART 8A or equivalent computer experience.

**Transferable:** CSU; UC; GAV-GE: C1

The study of digital photography from digital camera to the computer-based printer or digital media. Artistic, theoretical, and technical aspects will be considered. Topics include information about types and purchasing of digital cameras; theory, mechanics, and art of digital imagery; digital darkroom; eccentricities of digital photo taking; stitching photos for virtual reality; and preparing digital images for print, World Wide Web and other digital media. This course has the option of a letter grade or credit/no credit. This course is also listed as ART 80 and CSIS 80.

4277	L/L	AR103	EDBERG J	5.00	3.0	M&2	1245P-0315P	25 35 95
------	-----	-------	----------	------	-----	-----	-------------	----------

		LI128	EDBERG J			M	0210P-0325P	
--	--	-------	----------	--	--	---	-------------	--

**DM 85 Web Design I: Dreamweaver**

**Advisory:** CSIS 6 or basic knowledge of HTML.

**Transferable:** CSU; GAV-GE: C1

Basic and intermediate principles of designing Web pages/sites using the Dreamweaver web design software and HTML. Emphasis will be on good design and the use of tables, frames, forms, rollovers, DHTML, XHTML, behaviors, and CSS. Also includes site maintenance and the integration of multimedia components such as graphics, sound, animation, and video. This course is for the content person to design, develop, and maintain effective Web sites. This course is also listed as ART 85 and CSIS 85. This course has the option of a letter grade or credit/no credit. May be repeated twice for credit.

4278	LEC	BU111	THOMPSON F	4.00	2.0	F	0900A-1250P	11 25
------	-----	-------	------------	------	-----	---	-------------	-------

**03/10/06 - 05/19/06**

Sect.	Type	Room	Instructor	Hrs.	Units	Days	Begin-End	Footnotes
-------	------	------	------------	------	-------	------	-----------	-----------

**DM 107 Digital Media Design**

**Advisory:** CSIS 1 or CSIS 2/2L or equivalent computer experience

**Transferable:** CSU

Fundamentals of design for visual, time-based, interactive, and sound arts as applied to digital media. Includes basic storytelling, graphic design, information architecture, and human factors. Page layout, scriptwriting, storyboards, and flow charts will be used as tools applicable to the design and development of business presentations, interactive media, educational multimedia, animation, web sites, video games, and film/video. This course has the option of a letter grade or credit/no credit. Also listed as ART 107 and CSIS 107.

4279	L/L	LI128	BEEDER	3.00	2.0	W	1245P-0300P	25
------	-----	-------	--------	------	-----	---	-------------	----

**DM 108 Digital Media Lab**

**Advisory:** CSIS 1 or CSIS 2/2L or equivalent computer experience.

**Transferable:** CSU

Supervised practice and individualized computer assisted learning or software applications and techniques commonly found in the design and production of digital media (e.g., digital art and imaging, digital photography, digital print, digital audio/video, web design design/authoring, DVD/CD ROMs, animation). Supplements lecture courses. Open entry/exit, so may be added anytime during the semester. Graded credit/no credit only. Also listed as ART 108 and CSIS 108.

4280	LAB	LI128	BEEDER	1.50	.5	M	1110A-0150P	25 31
			BEEDER			W	1110A-1215P	

4281	LAB	LI128	EDBERG J	2.00	.5	M	0330P-0520P	25 31
------	-----	-------	----------	------	----	---	-------------	-------

**DM 113 Introduction to Digital Video**

**Advisory:** CSIS 1 or CSIS 2/2L or equivalent computer experience

**Transferable:** CSU

Introduction to the aesthetic and technical aspects of digital video recording, non-linear editing, special effect generation, and production of video (and associated audio) using the personal computer equipped with specialized software such as iMovie, Final Cut Pro, and After Effects. Also considered will be the preparation of digital video for use in interactive media such as CD, DVD, and the World Wide Web. Students will produce a final digital video project on DVD. This course has the option of a letter grade or credit/no credit. May be repeated 2 times for credit. Also listed as ART 113 and CSIS 113.

4282	L/L	LI128	BEEDER	5.00	3.0	MW&2	0945A-1100A	25 35
------	-----	-------	--------	------	-----	------	-------------	-------

**DM 114 Digital Media Production**

**Advisory:** At least one of the following: ART 75, CGE 2, JOUR 18A, MUS 21, CSIS 7, CSIS 71, OR CSIS 77. or possess equivalent skills from any one of the following areas: digital media, computer graphics, digital print, film, TV/video, journalism (publishing), drawing or illustration, web design/development, business/marketing, or programming.

**Transferable:** CSU

A team oriented practicum that focuses on the application of learned skills to the production of digital media and digital print projects, such as web sites, CD ROM, and DVDs. Project development will be accomplished according to team derived master schedules. Lectures will be on project management, work coordination and production techniques, client-team interface, asset management and integration, budget estimates, testing, and copyright infringement. Please note that this is very much a team oriented class. This course has the option of a letter grade or credit/no credit. This course is also listed as ART 114 and CSIS 114.

4283	LEC	LI128	BEEDER	2.00	2.0	M	1110A-0100P	25
------	-----	-------	--------	------	-----	---	-------------	----

**DM 140 Basic Digital Film/Video Production**

**Transferable:** CSU; UC

An on-line self-paced course covering the basics of film/video production and post production (editing) using "easy to use" computer software such as Apple's iMovie. Beneficial for students who are producing a video/film project as a requirement for another college course, extra skills development, or for self interest. Completion of the associated class or personal project in DVD format using either personal video equipment or the equipment in the Digital Media Studio is required. May be repeated twice for credit. This course has the option of a letter grade or credit/no credit. This course is also listed as ART 140 and CSIS 140.

4284	ONLINE	BEEDER		1.00	1.0	DHR	0000-0000	25 38
------	--------	--------	--	------	-----	-----	-----------	-------

**This online class will be delivered entirely over the internet. After enrolling, start the class by going to <http://www.gavilan.edu/disted/>, click on your class link, and email the instructor at [rbeede@gavilan.edu](mailto:rbeede@gavilan.edu). Students who have not begun the class or contacted the instructor by 5 pm on January 26 will be dropped from the class.**



Sect.	Type	Room	Instructor	Hrs.	Units	Days	Begin-End	Footnotes
-------	------	------	------------	------	-------	------	-----------	-----------

**Drama: See Theatre Arts****Early Childhood Education: See Child Development****Earth Science: See Geology, Geography****ECOLOGY****ECOL 1 Conservation of Natural Resources****Advisory:** Eligible for English 250 and English 260.**Transferable:** CSU; UC; CSU-GE: B2, B3; IGETC: 5B; GAV-GE: B2, B3

This course examines the fundamentals of ecology (the study of the relationships between organisms and their environment) with special emphasis on human effects on the environment. Topics of discussion will include ecosystem dynamics, resources, pollution, population growth, and the clash between economic and political policy and the environment.

4285	L/L	LS101 LS102	LAAGE S LAAGE S	6.00	4.0	TuTh Tu	1245P-0200P 0210P-0500P	1
4286	L/L	LS101 LS102	LAAGE S LAAGE S	6.00	4.0	TuTh Th	1245P-0200P 0210P-0500P	1

**ECONOMICS****ECON 1 Principles of Macroeconomics****Advisory:** Eligible for English 1A and Mathematics 233.**Transferable:** CSU; UC; CSU-GE: D2; IGETC: 4B; GAV-GE: D2; CAN: ECON 2

Introduction to the principles of macroeconomics, social organization of the economy; supply and demand; the determinants of national income and production, economic growth, the global economy and trade, employment, prices, savings and investment; the nature and effectiveness of monetary and fiscal policy. This course has the option of a letter grade or credit/no credit.

4287	LEC	BU120	MILLER K	3.00	3.0	MW	1110A-1225P	
4288	LEC	BU120	MILLER K	3.00	3.0	TuTh	1245P-0200P	
6078	LEC	SS205	STAFF	3.00	3.0	W	0600P-0850P	

**ECON 2 Principles of Microeconomics****Advisory:** Eligible for English 260, English 250 and Mathematics 233.**Transferable:** CSU; UC; CSU-GE: D2; IGETC: 4B; GAV-GE: D2; CAN: ECON 4

Introduction to microeconomic principles and theory; supply, demand; product and factor price determination, resource allocation, costs, revenues, and profits under different competitive situations; international trade; government regulation and taxation. Note: Economics 1 is not a prerequisite for Economics 2. This course has the option of a letter grade or credit/no credit.

4289	LEC	BU120	MILLER K	3.00	3.0	TuTh	1110A-1225P	
------	-----	-------	----------	------	-----	------	-------------	--

**ECON 11 Statistics for Business and Economics****Prerequisite:** Mathematics 233.**Transferable:** CSU; UC; CSU-GE: B4; IGETC: 2A; GAV-GE: B4

Statistical methods for business/economics analysis; descriptive statistics, inference, correlation and regression, probability, time series analysis. This course has the option of a letter grade or credit/no credit. This course is also listed as GBUS 11.

4290	LEC	BU120	LITTIG A	4.00	4.0	MW	1245P-0235P	25
------	-----	-------	----------	------	-----	----	-------------	----

**Education: See Child Development****Your educational plan:**

You are expected to take the responsibility for scheduling an appointment with a counselor, preferably at least once a semester. The purpose of this appointment is to develop, review and update your educational plan to ensure that you are taking the appropriate courses to meet your educational goal.

Sect.	Type	Room	Instructor	Hrs.	Units	Days	Begin-End	Footnotes
-------	------	------	------------	------	-------	------	-----------	-----------



Sect. Type Room Instructor Hrs. Units Days Begin-End Footnotes

## ENGLISH

## ENGL 1A Composition

**Prerequisite:** English 250 and English 260 with a grade of 'C' or better or satisfactory score on the English placement examination.

**Transferable:** CSU; UC; CSU-GE: A2; IGETC: 1A; GAV-GE: A2; CAN: ENGL 2, ENGL SEQ. A  
This is a writing course which emphasizes expository writing, argumentative writing, and critical reading of expository prose. It is meant to train students in clear thinking and reasoned support of ideas. Students will be given the opportunity to read models of good expository and argumentative prose and learn the techniques of good writing. These include choosing appropriate subjects, developing restricted, unified, and precise theses and presenting supporting evidence in a logical, lucid, and effective manner. To achieve this end, students write no fewer than six essays and read at least five works, two of which are book length.

4291	LEC	HU103	SANDLER S	3.00	3.0	MW	0810A-0925A	1
4292	LEC	SS203	SANDLER S	3.00	3.0	MW	0945A-1100A	1
4293	LEC	HU103	CONDON D	3.00	3.0	TuTh	0945A-1100A	1
4294	LEC	HOL1	STAFF	3.00	3.0	TuTh	1030A-1145A	1

**Section 4294 meets at the Hollister Briggs site.**

4295	LEC	MHG4	JACKSON S	3.00	3.0	TuTh	1030A-1145A	1
------	-----	------	-----------	------	-----	------	-------------	---

**Section 4295 meets at Morgan Hill Community site.**

4297	LEC	HU102	SALVIN C	3.00	3.0	TuTh	1110A-1225P	1
------	-----	-------	----------	------	-----	------	-------------	---

**Section 4297 will focus on the environment.**

4298	LEC	HU103	JACKSON S	3.00	3.0	F	1110A-0200P	1
------	-----	-------	-----------	------	-----	---	-------------	---

4299	LEC	HU102	SCHWARTZ Y	3.00	3.0	MW	1245P-0200P	1
------	-----	-------	------------	------	-----	----	-------------	---

4300	LEC	HU103	LUOMA D	3.00	3.0	TuTh	1245P-0200P	1
------	-----	-------	---------	------	-----	------	-------------	---

**Section 4300 will explore great American classics.**

4301	LEC	HU102	SCHWARTZ Y	3.00	3.0	MW	0400P-0515P	1
------	-----	-------	------------	------	-----	----	-------------	---

4302	ONLINE	CROOKE		3.00	3.0	TBA	0000-0000	38
------	--------	--------	--	------	-----	-----	-----------	----

**After enrolling in this online class, start by going to <http://www.gavilan.edu/disted/>, click on your class link, and email the instructor at [ecrook@gavilan.edu](mailto:ecrook@gavilan.edu). Students who have not begun the class or contacted the instructor by 5 pm on January 26 will be dropped from the class.**



4303	ONLINE	CHAFFIN C		3.00	3.0	DHR	0000-0000	38
------	--------	-----------	--	------	-----	-----	-----------	----

**Section 4303 will focus on personal essay/autobiography. After enrolling in this online class, start by going to <http://www.gavilan.edu/disted/>, click on your class link, and email the instructor at [cchaffin@gavilan.edu](mailto:cchaffin@gavilan.edu). Students who have not begun the class or contacted the instructor by 5 pm on January 26 will be dropped from the class.**



4304	ONLINE	CHAFFIN C		3.00	3.0	DHR	0000-0000	38
------	--------	-----------	--	------	-----	-----	-----------	----

**Section 4304 will focus on personal essay/autobiography. After enrolling in this online class, start by going to <http://www.gavilan.edu/disted/>, click on your class link, and email the instructor at [cchaffin@gavilan.edu](mailto:cchaffin@gavilan.edu). Students who have not begun the class or contacted the instructor by 5 pm on January 26 will be dropped from the class.**



6079	LEC	HU102	KOVACS M	3.00	3.0	S	0910A-1200P	155
------	-----	-------	----------	------	-----	---	-------------	-----

6080	LEC	HU103	BRETT T	3.00	3.0	M	0630P-0920P	1
------	-----	-------	---------	------	-----	---	-------------	---

6081	LEC	HOL2	PARKER V	3.00	3.0	Tu	0630P-0920P	1
------	-----	------	----------	------	-----	----	-------------	---

**Section 6081 meets at the Hollister Briggs site**

6082	LEC	MHG3	JACKSON J	3.00	3.0	Th	0630P-0920P	1
------	-----	------	-----------	------	-----	----	-------------	---

**Section 6082 will explore the American dream and meets at Morgan Hill Community site.**

**For additional ENGL 1A options see below.**

## ENGLISH - PUENTE

The Puente Project is a two-semester program that combines three components: writing, counseling and mentoring to support students to transfer to four-year universities and colleges. The Guidance 1 course focuses on self-assessment and career development. The English 1A course focuses on Mexican-American Latino literature. The program is open to all eligible students. For more information, call Celia Marquez, Puente Co-Coordinator at 408-848-4807.

## ENGL 1A Composition

4296	LEC	HU103	CANDELARIA X	3.00	3.0	TuTh	1110A-1225P	182
------	-----	-------	--------------	------	-----	------	-------------	-----

## GUID 1 Self-Assessment and Career Development

4413	LEC	CH102	MARQUEZ C	2.00	2.0	MW	1110A-1200P	50 82 89
------	-----	-------	-----------	------	-----	----	-------------	----------

Sect. Type Room Instructor Hrs. Units Days Begin-End Footnotes

## ENGLISH - continued

## ENGL 1B Composition and Literature

**Prerequisite:** English 1A with a grade of "C" or better.

**Transferable:** CSU; UC; CSU-GE: C ; IGETC: 3B; GAV-GE: C2; CAN: ENGL 4, ENGL SEQ. A

English 1B continues the work begun in 1A, but now the emphasis shifts to writing expository prose in conjunction with reading and analyzing imaginative literature. Students are to write as fledgling critics and use the text as a basis for other forms of reflection. The reading requirement includes short stories, poetry, drama, and at least two novels. Course work will also include fundamentals of research writing.

4305	LEC	HU103	LUOMA D	3.00	3.0	TuTh	0810A-0925A	1
------	-----	-------	---------	------	-----	------	-------------	---

**Section 4305 will explore great American classics.**

4306	LEC	HU102	SANDLER S	3.00	3.0	F	0810A-1100A	1
------	-----	-------	-----------	------	-----	---	-------------	---

**Section 4306 will explore the rich literary theme of remaining idle and slacking off.**

4307	LEC	MHG12	JAMES R	3.00	3.0	MW	0900A-1015A	1
------	-----	-------	---------	------	-----	----	-------------	---

**Above class meets at Morgan Hill Community site**

4308	LEC	HU103	RICHARDS G	3.00	3.0	MW	0945A-1100A	1
------	-----	-------	------------	------	-----	----	-------------	---

4309	LEC	HU103	RICHARDS G	3.00	3.0	MW	1110A-1225P	1
------	-----	-------	------------	------	-----	----	-------------	---

4310	LEC	HU103	CROOKE	3.00	3.0	MW	1245P-0200P	1
------	-----	-------	--------	------	-----	----	-------------	---

4311	LEC	CJ500	JACKSON S	3.00	3.0	TuTh	1245P-0200P	1
------	-----	-------	-----------	------	-----	------	-------------	---

**Section 4311 will take a journey into Southern literature.**

4312	LEC	HU102	CAMOZZIA	3.00	3.0	TuTh	0400P-0515P	1
------	-----	-------	----------	------	-----	------	-------------	---

4313	ONLINE	HOOPER J		3.0	TBA		0000-0000	
------	--------	----------	--	-----	-----	--	-----------	--

**After enrolling in this online class, start by going to <http://www.gavilan.edu/disted/>, click on your class link, and email the instructor at [jhooper@gavilan.edu](mailto:jhooper@gavilan.edu). Students who have not begun the class or contacted the instructor by 5 pm on January 26 will be dropped from the class. This online class has two mandatory meetings on campus: Friday, January 27 and Friday, April 28 from 1-3:30 pm in HU 102.**



4314	ONLINE	WARREN K		3.00	3.0	TBA	0000-0000	
------	--------	----------	--	------	-----	-----	-----------	--

**This online class will be delivered entirely over the internet. After enrolling, start the class by going to <http://www.gavilan.edu/disted/>, click on your class link, and email the instructor at [kwarren@gavilan.edu](mailto:kwarren@gavilan.edu). Students who have not begun the class or contacted the instructor by 5 pm on January 26 will be dropped from the class.**



6083	LEC	HU103	BRETT T	3.00	3.0	W	0630P-0920P	1
------	-----	-------	---------	------	-----	---	-------------	---

## ENGL 1C Critical Reasoning and Writing

**Prerequisite:** English 1A with a grade of "C" or better.

**Transferable:** CSU; UC; CSU-GE: A3; IGETC: 1B; GAV-GE: C2

This course is designed to develop critical thinking, reading, and writing skills beyond the level achieved in English 1A. The emphasis is on critical analysis of arguments and the development of the ability to integrate the principles of critical thinking into essay writing.

4315	LEC	HU102	CONDON D	3.00	3.0	TuTh	0810A-0925A	1
------	-----	-------	----------	------	-----	------	-------------	---

4316	LEC	HOL1	WISDOM K	3.00	3.0	MW	0900A-1015A	1
------	-----	------	----------	------	-----	----	-------------	---

**Above class meets at the Hollister Briggs site**

4317	LEC	MHG12	JAMES R	3.00	3.0	MW	1030A-1145A	1
------	-----	-------	---------	------	-----	----	-------------	---

**Above class meets at Morgan Hill Community site**

4318	LEC	HU102	CANDELARIA X	3.00	3.0	TuTh	1245P-0200P	1
------	-----	-------	--------------	------	-----	------	-------------	---

4319	LEC	HU102	SCHWARTZ Y	3.00	3.0	MW	0215P-0330P	1
------	-----	-------	------------	------	-----	----	-------------	---

4320	ONLINE	CANDELARIA X		3.00	3.0	TBA	0000-0000	38
------	--------	--------------	--	------	-----	-----	-----------	----

**After enrolling in this online class, start by going to <http://www.gavilan.edu/disted/>, click on your class link, and email the instructor at [xcandelaria@gavilan.edu](mailto:xcandelaria@gavilan.edu). Students who have not begun the class or contacted the instructor by 5 pm on January 26 will be dropped from the class.**



6084	LEC	HU102	BRETT T	3.00	3.0	Th	0630P-0920P	1
------	-----	-------	---------	------	-----	----	-------------	---

## ENGL 2B Introduction to Multi-Cultural Literature

**Prerequisite:** Eligible for English 1A.

**Transferable:** CSU; UC; CSU-GE: C2; IGETC: 3B; GAV-GE: C2, F

Students will examine the concept of ethnicity in the context of contemporary American multi-ethnic literature: Native American, Hispanic American, Black American, Asian American. Students will critique this literature using the accepted elements of literary criticism. They will read and analyze selections from each literature and explain their results in journals, oral presentations, a research project and examinations.

4321	LEC	SS111	LOOTSL	3.00	3.0	MW	1245P-0200P	
------	-----	-------	--------	------	-----	----	-------------	--

Sect.	Type	Room	Instructor	Hrs.	Units	Days	Begin-End	Footnotes
-------	------	------	------------	------	-------	------	-----------	-----------

**ENGL 2C Introduction to Film and Fiction****Prerequisite:** Eligible for English 1A.**Transferable:** CSU; UC; CSU-GE: C2; IGETC: 3B; GAV-GE: C2

This is a literature course in analysis of the novel and film as art forms. The student will read several novels, view the films based on the novels, and discuss the difference in techniques, both orally and in writing.

6085	LEC	SS214	RICHARDS G	3.00	3.0	Th	0630P-0920P	
------	-----	-------	------------	------	-----	----	-------------	--

**ENGL 5A Survey of American Literature - 1620 to 1865****Prerequisite:** Eligible for English 1A.**Transferable:** CSU; UC; CSU-GE: C2; IGETC: 3B; GAV-GE: C2; CAN: ENGL 14, ENGL SEQ. C

This course is a study of the masters of American literature covering the years 1620 to 1865 A.D.

4322	ONLINE	JAMES R		3.00	3.0	DHR	0000-0000	38
------	--------	---------	--	------	-----	-----	-----------	----

**This online class will be delivered entirely over the internet. After enrolling, start the class by going to <http://www.gavilan.edu/disted/>, click on your class link, and email the instructor at [rjames@gavilan.edu](mailto:rjames@gavilan.edu). Students who have not begun the class or contacted the instructor by 5 pm on January 26 will be dropped from the class.**

**ENGL 9A Introduction to Creative Writing****Prerequisite:** Eligible for English 1A.**Transferable:** CSU; UC; CSU-GE: C2; GAV-GE: C2; CAN: ENGL 6

This course includes the writing, reading, and critical discussions of various forms of poetry and fiction.

4323	LEC	HU102	SALVIN C	3.00	3.0	TuTh	0945A-1100A	
------	-----	-------	----------	------	-----	------	-------------	--

6086	LEC	HU102	CANDELARIA X	3.00	3.0	W	0530P-0820P	
------	-----	-------	--------------	------	-----	---	-------------	--

**ENGL 9B Advanced Creative Writing****Prerequisite:** English 9A with a grade of credit or C or better.**Transferable:** CSU; UC; CSU-GE: C2; GAV-GE: C2

This class is a continuation of English 9A, with the emphasis shifting to publication. The genre of non-fiction will be the primary focus, but the genres of fiction will also be taught at a more comprehensive level than in English 9A. The process of finding a market for one's work will be followed step by step. The class may compile and publish Soaring, Gavilan's literary magazine, each spring semester.

4324	LEC	HU102	SALVIN C	3.00	3.0	TuTh	0945A-1100A	
------	-----	-------	----------	------	-----	------	-------------	--

6087	LEC	HU102	CANDELARIA X	3.00	3.0	W	0530P-0820P	
------	-----	-------	--------------	------	-----	---	-------------	--

**ENGL 9C Poetry Writing****Prerequisite:** English 9A with a grade of credit or C or better.**Transferable:** CSU; UC; CSU-GE: C2; GAV-GE: C2

This course includes the writing, reading, and critical discussions of various forms of poetry.

4325	LEC	HU102	SALVIN C	3.00	3.0	TuTh	0945A-1100A	
------	-----	-------	----------	------	-----	------	-------------	--

6088	LEC	HU102	CANDELARIA X	3.00	3.0	W	0530P-0820P	
------	-----	-------	--------------	------	-----	---	-------------	--

**ENGL 12A Tutoring Writers: Training, Theory & Practice****Advisory:** Eligible for English 1A.**Transferable:** CSU

Fundamentals of compositional theory, the writing process, peer-to-peer communication, interacting with faculty and educational institutions and effective responses to writing will be covered. In addition, students will gain an understanding of the basic history, methodology and practice of writing pedagogy while developing a writing community that aids in connecting them to their own writing practice.

4326	LEC/online	LI120	SMITH K	2.00	2.0	Th	0200P-0400P	13
------	------------	-------	---------	------	-----	----	-------------	----

**This HYBRID lecture/online class will be delivered partially over the internet. Come to the campus for the first day of class.**

**ENGL 12B Tutoring Writers: Training, Theory & Practice****Advisory:** Eligible for English 1A.**Transferable:** CSU

Fundamentals of compositional theory, the writing process, peer-to-peer communication, interacting with faculty and educational institutions and effective responses to writing will be covered. In addition, students will gain an understanding of the basic history, methodology and practice of writing pedagogy while developing a writing community that aids in connecting them to their own writing practice.

4327	LEC	LI120	SMITH K	2.00	2.0	Th	0200P-0400P	13
------	-----	-------	---------	------	-----	----	-------------	----

**This HYBRID lecture/online class will be delivered partially over the internet. Come to the campus for the first day of class.**



Sect.	Type	Room	Instructor	Hrs.	Units	Days	Begin-End	Footnotes
-------	------	------	------------	------	-------	------	-----------	-----------

**ENGL 2B****Introduction to Multi-cultural Literature**

Instructor: Louise Loots

Explore our multicultural history, culture, and society through literature.

Mexican American

Asian American

African American

Native American

Short stories, novels, and poetry

3 units Transfer: CSU/UC

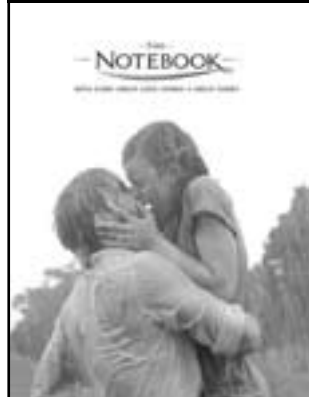

Sect. 4321  
MW  
12:45 - 2 pm

**Film & Fiction ENGL 2C**

Instructor - Grant Richards

Sect. 6085  
Thursday 6:30-9:20 pm

*Sideways**Motorcycle Diaries**Closer**Fight Club**Notebook**High Fidelity**The Shawshank Redemption**To Kill a Mockingbird**The Joyluck Club**About a Boy**The Color Purple**The Cider House Rules**One Flew Over the Cuckoo's Nest**Chocolat**LA Confidential**Schindler's List**Get Shorty**and more!*

*This class can fulfill your IGETC humanities transfer requirement.*

**English 9A, B, C****CREATIVE WRITING**

Sects. 6086, 6087, 6088

Wednesday evening  
from 5:30-8:20 pm  
with Xochi Candelaria

Xochi Candelaria is both a writer and translator of poetry.



Sects. 4323, 4324, 4325

Tuesday and Thursday  
from 9:45 - 11:00 am  
with Christina Salvin

Christina Salvin hopes that her (and your) writing will shake the world.

*This class fulfills your CSU humanities transfer requirement.*

Sect.	Type	Room	Instructor	Hrs.	Units	Days	Begin-End	Footnotes
-------	------	------	------------	------	-------	------	-----------	-----------

### ENGL 12C Tutoring Writers: Training, Theory & Practice

**Advisory:** Eligible for English 1A.

**Transferable:** CSU

Fundamentals of compositional theory, the writing process, peer-to-peer communication, interacting with faculty and educational institutions and effective responses to writing will be covered. In addition, students will gain an understanding of the basic history, methodology and practice of writing pedagogy while developing a writing community that aids in connecting them to their own writing practice.

4328	LEC	LI120	SMITH K	2.00	2.0	Th	0200P-0400P	13
------	-----	-------	---------	------	-----	----	-------------	----

**H** This HYBRID lecture/online class will be delivered partially over the internet. Come to the campus for the first day of class.

### ENGL 23 Independent Study

**Required:** The study outline prepared by the student and the instructor must be filed with the department and the dean.

**Transferable:** CSU

Designed to afford selected students specialized opportunities for exploring areas at the independent study level. The courses may involve extensive library work, research in the community, or special projects. May be repeated until six units of credit are accrued. This course has the option of a letter grade or credit/no credit.

4329	IND	HU111	RICHARDS G	3.00	1.0	DHR	0000-0000	22
4330	IND	HU112	CANDELARIA X	6.00	2.0	DHR	0000-0000	22
4331	IND	LI202	CROOK E	6.00	2.0	DHR	0000-0000	22
4332	IND	SS103	SALVIN C	6.00	2.0	DHR	0000-0000	22
4333	IND	SS109	WARREN K	6.00	1.0	DHR	0000-0000	22
4334	IND	SS109	WARREN K	6.00	2.0	DHR	0000-0000	22

### ENGL 250 Practical Writing

**Prerequisite:** English 440 or ESL 563 with a grade of 'C' or better or satisfactory score on the English placement examination.

**Transferable:** No; GAV-GE: A2

This course covers writing clear, correct, effective essays and learning preliminary research skills.

4335	L/L	SS203	STAFF	4.00	3.0	MW	0810A-0925A	118
		LI171	STAFF			M	0945A-1035A	
4336	L/L	SS203	STAFF	4.00	3.0	MW	0810A-0925A	118
		LI171	STAFF			W	0945A-1035A	
4337	L/L	HU102	SALVIN C	4.00	3.0	MW	0945A-1100A	118
		LI171	SALVIN C			F	0810A-0900A	

**Section 4337 will explore American consumerism and alternatives.**

4338	L/L	HU102	SALVIN C	4.00	3.0	MW	0945A-1100A	118
		LI171	SALVIN C			F	0910A-1000A	

**Section 4338 will explore American consumerism and alternatives.**

4339	L/L	SS203	STAFF	4.00	3.0	TuTh	0945A-1100A	118
		LI171	STAFF			Tu	1110A-1200P	

4340	L/L	SS203	STAFF	4.00	3.0	TuTh	0945A-1100A	118
		LI171	STAFF			Th	1110A-1200P	

4341	L/L	HOL1	WISDOM K	4.00	3.0	MW	1030A-1145A	118
			WISDOM K			M	1200P-1250P	

4342	L/L	HOL1	WISDOM K	4.00	3.0	MW	1030A-1145A	118
			WISDOM K			W	1200P-1250P	

**Section 4342 meets at the Hollister Briggs site**

4343	L/L	HU102	SALVIN C	4.00	3.0	MW	1110A-1225P	118
		LI171	SALVIN C			F	1010A-1100A	

**Section 4343 will explore American consumerism and alternatives.**

4344	L/L	HU102	SALVIN C	4.00	3.0	MW	1110A-1225P	118
		LI171	SALVIN C			F	1110A-1200P	

**Section 4344 will explore American consumerism and alternatives.**

4349	L/L	SS203	CAMOZZI A	4.00	3.0	TuTh	0215P-0330P	118
		LI171	CAMOZZI A			Tu	0110P-0200P	

4350	L/L	SS203	CAMOZZI A	4.00	3.0	TuTh	0215P-0330P	118
		LI171	CAMOZZI A			Th	0110P-0200P	

4351	L/L	SS203	HIRASUNA S	4.00	3.0	MW	0400P-0515P	118
		LI120	HIRASUNA S			M	0300P-0350P	

**Section 4351 will have a multicultural emphasis.**

4352	L/L	SS203	HIRASUNA S	4.00	3.0	MW	0400P-0515P	118
		LI120	HIRASUNA S			W	0300P-0350P	

**Section 4352 will have a multicultural emphasis.**

6089	L/L	HOL1	PARKER V	4.00	3.0	Th	0530P-0920P	1
------	-----	------	----------	------	-----	----	-------------	---

**Section 6089 meets at the Hollister Briggs site**

6090	L/L	SS203	GRAY J	4.00	3.0	MW	0700P-0850P	148
------	-----	-------	--------	------	-----	----	-------------	-----

Students enrolling in section 6090 are encouraged to also enroll in ENGL 260, section 6091.

**For additional ENGL 250 options see the First Year Experience section (right column).**

Sect.	Type	Room	Instructor	Hrs.	Units	Days	Begin-End	Footnotes
-------	------	------	------------	------	-------	------	-----------	-----------

### ENGL 260 Preparation for College Reading

**Prerequisite:** Completion of English 420 or Assessment recommendation.

**Transferable:** No; GAV-GE: A3

This is a course presenting strategies in the technique and practice of college level critical reading and thinking skills.

4353	LEC	SS111	TRACEY I	3.00	3.0	MW	0945A-1100A	1
4358	LEC	SS203	STAFF	3.00	3.0	F	1110A-0200P	1
4359	LEC	SS203	STAFF	3.00	3.0	MW	1245P-0200P	1
6091	LEC	SS203	GRAY J	3.00	3.0	MW	0530P-0645P	148

Students enrolling in section 6091 are encouraged to also enroll in ENGL 250, section 6090.

**For additional ENGL 260 options see below.**

## ENGLISH - FIRST YEAR EXPERIENCE

### Starting your first semester at Gavilan?

Then this learning community program is specially designed for you.

The first year of college can be challenging for many students. By studying and working together with your classmates and instructors, in this program you'll develop a strong network of support to help you succeed. You'll improve your reading and writing skills and also explore options for majors, transferring, and careers. Building a strong foundation in your first year will put you on the road to success throughout your college experience.

### The Program:

Students will take reading, writing and guidance together because these skills are needed to succeed in college classes.

**The following classes are part of a First Year Experience-learning community. You must enroll in all three courses.**

### ENGL 250 Practical Writing

This class explores culture and language.

4345	L/L	CH102	HULL K	4.00	3.0	TuTh	1110A-1225P	11885
		SS203	HULL K			Tu	0835A-0925A	

### ENGL 260 Preparation for College Reading

4354	LEC	CH102	HOOPER J	3.00	3.0	TuTh	0945A-1100A	185
------	-----	-------	----------	------	-----	------	-------------	-----

### GUID 1 Self-Assessment and Career Development

4411	LEC	HU104	GODLEY J	2.00	2.0	F	0910A-1100A	8589
------	-----	-------	----------	------	-----	---	-------------	------

**The following classes are part of a First Year Experience-learning community. You must enroll in all three courses.**

### ENGL 250 Practical Writing

This class explores culture and language.

4346	L/L	CH102	HULL K	4.00	3.0	TuTh	1110A-1225P	11885
		SS203	HULL K			Th	0835A-0925A	

### ENGL 260 Preparation for College Reading

4355	LEC	CH102	HOOPER J	3.00	3.0	TuTh	0945A-1100A	185
------	-----	-------	----------	------	-----	------	-------------	-----

### GUID 1 Self-Assessment and Career Development

4412	LEC	HU104	GODLEY J	2.00	2.0	F	0910A-1100A	8589
------	-----	-------	----------	------	-----	---	-------------	------

**Have you met the prerequisite?  
It's required!**

Sect.	Type	Room	Instructor	Hrs.	Units	Days	Begin-End	Footnotes
-------	------	------	------------	------	-------	------	-----------	-----------

**The following classes are part of a First Year Experience-learning community. You must enroll in all three courses.**

**ENGL 250 Practical Writing**

This class explores culture and language.

4347	L/L	SS203 LI171	HULL K HULL K	4.00	3.0	TuTh Tu	1245P-0200P 0210P-0300P	118 85
------	-----	----------------	------------------	------	-----	------------	----------------------------	--------

**ENGL 260 Preparation for College Reading**

4356	LEC	SS203	HOOPER J	3.00	3.0	TuTh	1110A-1225P	185
------	-----	-------	----------	------	-----	------	-------------	-----

**GUID 1 Self-Assessment and Career Development**

4414	LEC	SS206	WHITNEY C	2.00	2.0	F	1110A-0100P	85 89
------	-----	-------	-----------	------	-----	---	-------------	-------

**The following classes are part of a First Year Experience-learning community. You must enroll in all three courses.**

**ENGL 250 Practical Writing**

This class explores culture and language.

4348	L/L	SS203 LI171	HULL K HULL K	4.00	3.0	TuTh Th	1245P-0200P 0210P-0300P	118 85
------	-----	----------------	------------------	------	-----	------------	----------------------------	--------

**ENGL 260 Preparation for College Reading**

4357	LEC	SS203	HOOPER J	3.00	3.0	TuTh	1110A-1225P	185
------	-----	-------	----------	------	-----	------	-------------	-----

**GUID 1 Self-Assessment and Career Development**

4415	LEC	SS206	WHITNEY C	2.00	2.0	F	1110A-0100P	85 89
------	-----	-------	-----------	------	-----	---	-------------	-------

**ENGLISH - continued**

**ENGL 420 Reading Improvement**

**Prerequisite:** English 438 or English 439 with a grade of 'C' or better, or satisfactory score on the English placement examination.

**Transferable:** No

This is a practical, "how to" course teaching various methods of learning and reading college material. Using group and individual instruction in vocabulary, comprehension, and study skills, the students will increase their ability to survive academically, to profit, grow and succeed in all college courses, and to enjoy reading and learning. Units earned in this course do not count toward the associate degree and/or certain certificate requirements.

4364	L/L	SS111	CROOK E CROOK E	4.00	3.0	TuTh Th	1100A-1225P 1235P-0125P	1
4365	L/L	SS111	CROOK E CROOK E	4.00	3.0	TuTh Tu	1110A-1225P 1235P-0125P	1
6092	L/L	SS111	GARDNER L	4.00	3.0	TuTh	0530P-0645P	1 48

Students enrolling in section 6090 are encouraged to also enroll in ENGL 440, section 6093.

4366	L/L	SS203	STAFF	4.00	3.0	F	1110A-0200P	1
------	-----	-------	-------	------	-----	---	-------------	---

Section 4366 requires co-enrollment in ENGL 420L. Choose a section (listed below) that best fits your schedule.

**For additional ENGL 420 options see page 70.**

**ENGL 420L Reading Improvement Lab**

**Transferable:** No

Reading improvement lab for English 420.

4367	LAB	LI200	STAFF	.0	W		0810A-0900A	61
4368	LAB	LI200	STAFF	.0	Th		0945A-1035A	61
4369	LAB	LI200	STAFF	.0	F		1010A-1100A	61
4370	LAB	LI200	STAFF	.0	M		1110A-1200P	61
4371	LAB	LI200	STAFF	.0	Tu		1245P-0135P	61

**For additional ENGL 420 options see page 70.**

Sect.	Type	Room	Instructor	Hrs.	Units	Days	Begin-End	Footnotes
-------	------	------	------------	------	-------	------	-----------	-----------

**Gavilan College ENGLISH COMPOSITION COURSE SEQUENCE**

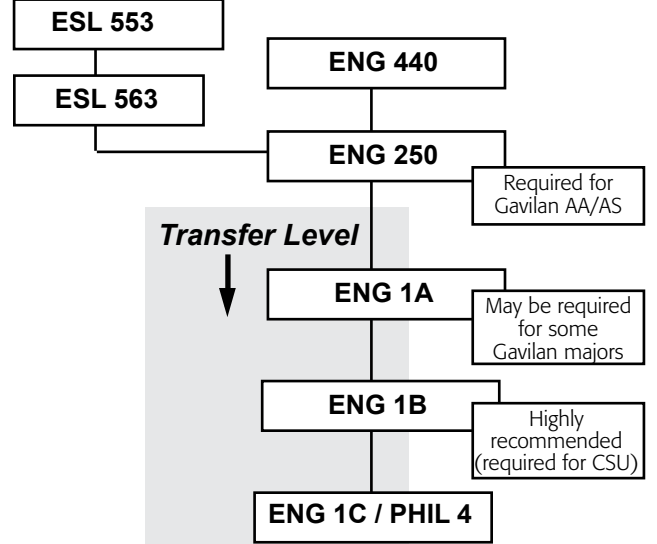

**Reading Course Sequence**

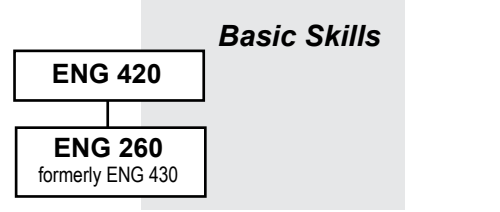

Multiple measures will be considered to determine your final course. Consult with a counselor to select the appropriate course.

**ENGL 5A**  
**Survey of American Literature**

Section 4322  
with Robert James

Now being offered online!

**UPGRADE YOUR COMPUTER SKILLS!**

TAKE CLASSES IN

- Digital Media
- Programming
- MS Office
- WebPage Design
- QuickBooks



Sect.	Type	Room	Instructor	Hrs.	Units	Days	Begin-End	Footnotes
-------	------	------	------------	------	-------	------	-----------	-----------

**ENGLISH - continued****ENGL 438 Basic Literacy****Advisory:** Assessment recommendation.**Transferable:** No

This is an individualized remediation course designed for students with low-level literacy skills. Emphasis will be in the areas of spelling, grammar, and punctuation skill, and sentence and paragraph construction. The course will also help students build vocabulary, develop reading strategies for better comprehension, and improve study skills. This course may be repeated three times for credit. This is a credit/no credit course. Units earned in this course do not count toward the associate degree and/or certain certificate requirements.

4372	LAB	HU102 LI120	TRACEY I TRACEY I	6.00	2.0	MW&2 F	0810A-0925A 0810A-0900A	
------	-----	----------------	----------------------	------	-----	-----------	----------------------------	--

**ENGL 440 Basic Writing****Prerequisite:** English 438 or English 439 with a grade of 'C' or better, or satisfactory score on the English placement examination.**Corequisite:** Concurrent enrollment in English 440L.**Transferable:** No

This is an intensive study and application of basic grammar, sentence, and essay writing skills within the context of composing short essays. Units earned in this course do not count toward the associate degree and/or certain certificate requirements.

4373	L/L	SS111 LI120	HESSE D HESSE D	4.00	3.0	TuTh Tu	0810A-0925A 1110A-1200P	118
4374	L/L	SS111 LI120	HESSE D HESSE D	4.00	3.0	TuTh Tu	0810A-0925A 1235P-0125P	118
4379	L/L	SS111 LI120	HESSE D HESSE D	4.00	3.0	TuTh Th	0945A-1100A 1110A-1200P	118
4380	L/L	SS111 LI120	HESSE D HESSE D	4.00	3.0	TuTh Th	0945A-1100A 1235P-0125P	118
4381	L/L	SS203 LI120	CROOK E CROOK E	4.00	3.0	MW M	1110A-1225P 1010A-1100A	118
4382	L/L	SS203 LI120	CROOK E CROOK E	4.00	3.0	MW W	1110A-1225P 1010A-1100A	118
6093	L/L	SS111	GARDNER L	4.00	3.0	TuTh	0700P-0850P	148

Students enrolling in section 6090 are encouraged to also enroll in ENGL 420, section 6092.

**For additional ENGL 440 options see below.**

**ENGLISH - LEARNING COMMUNITIES**

**The following classes are part of a learning community. You must enroll in both courses.**

**ENGL 420 Reading Improvement**

This class is about Speaking up, Speaking Out!: Voices at Home, at School, and Beyond.

4360	L/L	CJ500 LI120	SMITH K SMITH K	4.00	3.0	MW Tu	1030A-1145A 0810A-0900A	136
------	-----	----------------	--------------------	------	-----	----------	----------------------------	-----

**ENGL 440 Basic Writing**

This class is about Speaking up, Speaking Out!: Voices at Home, at School, and Beyond.

4375	L/L	CJ500 LI120	SMITH K SMITH K	4.00	3.0	MW Tu	0900A-1015A 0910A-1000A	118 36
------	-----	----------------	--------------------	------	-----	----------	----------------------------	--------

**The following classes are part of a learning community. You must enroll in both courses.**

**ENGL 420 Reading Improvement**

This class is about Speaking up, Speaking Out!: Voices at Home, at School, and Beyond.

4361	L/L	CJ500 LI120	SMITH K SMITH K	4.00	3.0	MW Th	1030A-1145A 0810A-0900A	136
------	-----	----------------	--------------------	------	-----	----------	----------------------------	-----

**ENGL 440 Basic Writing**

This class is about Speaking up, Speaking Out!: Voices at Home, at School, and Beyond.

4376	L/L	CJ500 LI120	SMITH K SMITH K	4.00	3.0	MW Th	0900A-1015A 0910A-1000A	118 36
------	-----	----------------	--------------------	------	-----	----------	----------------------------	--------

Sect.	Type	Room	Instructor	Hrs.	Units	Days	Begin-End	Footnotes
-------	------	------	------------	------	-------	------	-----------	-----------

**The following classes are part of a learning community. You must enroll in both courses.**

**ENGL 420 Reading Improvement**

This class is about Speaking up, Speaking Out!: Voices at Home, at School, and Beyond.

4362	L/L	CJ500 LI120	WARREN K WARREN K	4.00	3.0	MW F	1030A-1145A 0910A-1000A	136
------	-----	----------------	----------------------	------	-----	---------	----------------------------	-----

**ENGL 440 Basic Writing**

This class is about Speaking up, Speaking Out!: Voices at Home, at School, and Beyond.

4377	L/L	CJ500 LI120	WARREN K WARREN K	4.00	3.0	MW F	0900A-1015A 1010A-1100A	118 36
------	-----	----------------	----------------------	------	-----	---------	----------------------------	--------

**The following classes are part of a learning community. You must enroll in both courses.**

**ENGL 420 Reading Improvement**

This class is about Speaking up, Speaking Out!: Voices at Home, at School, and Beyond.

4363	L/L	CJ500 LI120	WARREN K WARREN K	4.00	3.0	MW F	1030A-1145A 1110A-1200P	136
------	-----	----------------	----------------------	------	-----	---------	----------------------------	-----

**ENGL 440 Basic Writing**

This class is about Speaking up, Speaking Out!: Voices at Home, at School, and Beyond.

4378	L/L	CJ500 LI120	WARREN K WARREN K	4.00	3.0	MW F	0900A-1015A 1210P-0100P	118 36
------	-----	----------------	----------------------	------	-----	---------	----------------------------	--------

**ENGLISH - HIGH STEP****ENGL 1A Composition****Prerequisite:** English 250 and English 260 with a grade of 'C' or better or satisfactory score on the English placement examination.**Transferable:** CSU; UC; CSU-GE: A2; IGETC: 1A; GAV-GE: A2; CAN: ENGL 2, ENGL SEQ. A

4751	LEC	GHSB-7	LUOMAD	3.00	3.0	M	0310P-0600P	1
------	-----	--------	--------	------	-----	---	-------------	---

Above class meets at Gilroy High School, rm. B-7

**ENGLISH AS A SECOND LANGUAGE**

Gavilan College ofrece cursos de Inglés como segundo idioma a todos los niveles, desde principiante hasta avanzado. Antes de inscribirse, los estudiantes deben hacer una cita para el examen de nivelación en la Oficina de Admisiones.

**ESL 501A Survival ESL I First Half****Advisory:** ESL assessment recommendation**Transferable:** No

This is the first half of a course in survival English for students with little or no oral or written English competency. It will give students basic vocabulary and familiarity in life skill areas such as the family, food, health, and occupations. The course integrates listening, speaking, reading, and writing. (ESL 501, 502, and 503 are sequential courses that may be taken in full form or in halves, preferably A before B.) This is a credit/no credit course.

6094	L/L	HOL5	CISNEROS N	5.00	3.0	M WF	0615P-0745P
------	-----	------	------------	------	-----	------	-------------

Above class meets at the Hollister Briggs site

6095	L/L	HU101	CARRILLO L	5.00	3.0	M W	0615P-0830P
------	-----	-------	------------	------	-----	-----	-------------

**ESL 502A Survival ESL II First Half****Advisory:** ESL 501 or ESL 501A and 501B or ESL assessment recommendation**Transferable:** No

This is the first half of a second course in survival English for students with little oral or written English competency. It will give students expanded basic vocabulary and familiarity in life skill areas such as the weather, transportation, employment, and American holidays and customs. The course integrates listening, speaking, reading, and writing. (ESL 501, 502, and 503 are sequential courses that may be taken in full form or in halves, preferably A before B.) This is a credit/no credit course.

6096	L/L	HU101	ZUNIGA J	5.00	3.0	TuTh	0615P-0830P
------	-----	-------	----------	------	-----	------	-------------

6097	L/L	HOL5	CISNEROS N	5.00	3.0	M WF	0800P-0925P
------	-----	------	------------	------	-----	------	-------------

Above class meets at the Hollister Briggs site

Sect. Type Room Instructor Hrs. Units Days Begin-End Footnotes

**ESL 503A Survival ESL III First Half**

**Advisory:** ESL 502 or ESL 502A and 502B or ESL assessment recommendation  
**Transferable:** No

This is the first half of a third course in survival English for students with beginning oral or written English competency. It will reinforce basic skills learned and continue to develop vocabulary and ease of communication in life skill areas such as the family, the larger community, health, employment, and leisure activities. The course integrates listening, speaking, reading, and writing. (ESL 501, 502, and 503 are sequential courses that may be taken in full form or in halves, preferably A before B.) This is a credit/no credit course.

6098	L/L	HOL4	DIEHL K	5.00	3.0	M W F	0615P-0745P
<b>Above class meets at the Hollister Briggs site</b>							
6099	L/L	HU104	SHELLEY A	5.00	3.0	M W	0615P-0830P

**ESL 503B Survival ESL III Second Half**

**Advisory:** ESL 502 or ESL 502A and 502B or ESL assessment recommendation  
**Transferable:** No

This is the second half of a third course in survival English for students with beginning oral or written English competency. It will reinforce basic skills learned and continue to develop vocabulary and ease of communication in life skill areas such as the family, the larger community, health, employment, and leisure activities. The course integrates listening, speaking, reading, and writing. (ESL 501, 502, and 503 are sequential courses that may be taken in full form or in halves, preferably A before B.) This is a credit/no credit course.

6100	L/L	HOL4	DIEHL K	5.00	3.0	M W F	0800P-0925P
<b>Above class meets at the Hollister Briggs site</b>							

**ESL 510A Basic ESL I**

**Advisory:** Assessment Recommendation.  
**Transferable:** No

This is an intensive, integrated-skill course for students with little English. Through listening, speaking, reading and writing activities, students learn to use the structures of English with increasing accuracy, while gaining basic life skills. This is a credit/no credit course.

4386	L/L	OE002	MORA J	12.00	8.0	DAILY	0810A-1000A
4387	L/L	OE001	CAMPBELL K	12.00	8.0	DAILY	0910A-1100A

**ESL 510B Basic ESL II**

**Advisory:** ESL 510A or ESL assessment recommendation.  
**Transferable:** No

This course is a continuation of ESL 510A. This is an intensive, integrated-skill program for students who function in a limited way in English. Through listening, speaking, reading and writing activities, students continue learning to use the structures of English with increasing accuracy, while gaining further basic life skills. This is a credit/no credit course.

4388	L/L	OE002	PORCELLA A	12.00	8.0	DAILY	1010A-1200P
------	-----	-------	------------	-------	-----	-------	-------------

**ESL 521 Beginning ESL Listening/Speaking**

**Advisory:** ESL 510B or ESL Assessment Test Recommendation. Recommended concurrent enrollment in ESL 522 and 523.  
**Transferable:** No

This course develops basic listening and speaking skills, moving from a functional survival context to academic readiness. Activities are directed at providing practice through listening exercises, role-play, pair work, small and large group discussion, interviews, and oral presentations.

4389	L/L	HU101	SANIDAD M	6.00	4.0	DAILY	0910A-1000A
------	-----	-------	-----------	------	-----	-------	-------------

**ESL 522 Beginning ESL Reading/Vocabulary**

**Advisory:** ESL 510B or 510C or Assessment recommendation. Recommended concurrent enrollment in ESL 521 and 523.  
**Transferable:** No

This course begins the development of reading skills and vocabulary through the application of different reading strategies to a variety of selections on topics of interest to academically-bound students.

4390	L/L	HU101	PORCELLA A	6.00	4.0	MWF&3	1210P-0100P
------	-----	-------	------------	------	-----	-------	-------------

**ESL 523 Beginning ESL Grammar/Writing**

**Advisory:** ESL 510B or ESL Assessment Test recommendation. Recommended concurrent enrollment in ESL 521 and ESL 522.  
**Transferable:** No

This is a beginning grammar/writing course for students with very basic grammar. The focus is on basic grammatical structures, punctuation and sentence skills.

4391	L/L	OE001	CAMPBELL K	6.00	4.0	DAILY	1110A-1200P
------	-----	-------	------------	------	-----	-------	-------------

Sect. Type Room Instructor Hrs. Units Days Begin-End Footnotes

**OVERVIEW OF ESL COURSES**

L/S = Listening/Speaking  
 R = Reading  
 GW = Grammar/Writing

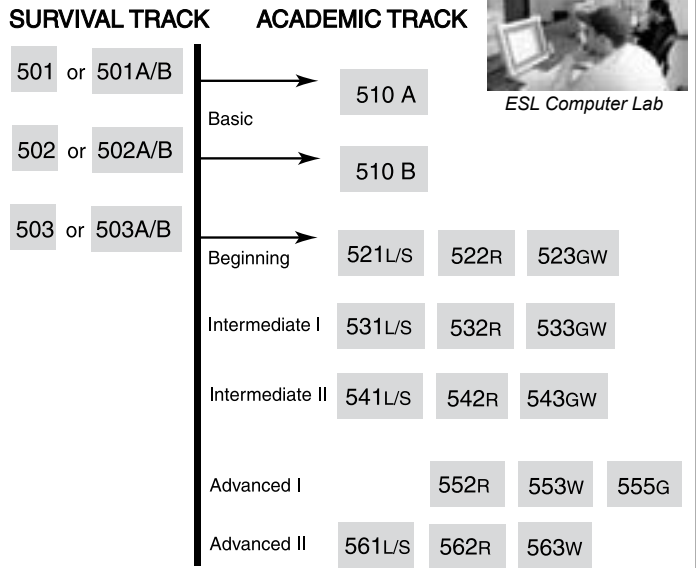

ESL Computer Lab

All new ESL students must go through the ESL Assessment Process. See page 10 for ESL testing and placement information

Sect.	Type	Room	Instructor	Hrs.	Units	Days	Begin-End	Footnotes
-------	------	------	------------	------	-------	------	-----------	-----------

**ESL 531 Intermediate ESL Listening/Speaking I**

**Advisory:** ESL 521 or ESL Assessment Test Recommendation. Recommended concurrent enrollment in ESL 532 and 533.

**Transferable:** No

In this course, listening and speaking skills are developed through extended listening exercises, open-ended dialogues, pair and group discussions, oral interviews, and oral reports. Units earned in this course do not count toward the associate degree and/or certain certificate requirements.

4392	L/L	HU101	PORCELLA A	6.00	4.0	DAILY	0810A-0900A	
------	-----	-------	------------	------	-----	-------	-------------	--

**ESL 532 Intermediate ESL Reading/Vocabulary I**

**Advisory:** ESL 522 or ESL Assessment Recommendation. Recommended concurrent enrollment in ESL 531 and 533.

**Transferable:** No

This course continues the development of reading skills and vocabulary through the application of different reading strategies to a variety of selections on topics of interest to academically-bound students.

4393	L/L	LI100	LAWN B	6.00	4.0	TuTh	1110A-1225P	
------	-----	-------	--------	------	-----	------	-------------	--

**ESL 533 Intermediate ESL Grammar/Writing I**

**Prerequisite:** ESL 523 with a grade of C or better or ESL Assessment Test recommendation.

**Corequisite:** Recommended concurrent enrollment in ESL 531 and ESL 532.

**Transferable:** No

This course involves the practice and refinement of sentence and paragraph skills, structure and punctuation. Students will learn basic use of the computer as a writing tool. Units earned in this course do not count toward the associate degree and/or certain certificate requirements.

4394	L/L	LI100	LAWN B	6.00	4.0	DAILY	1010A-1100A	
------	-----	-------	--------	------	-----	-------	-------------	--

**ESL 541 Intermediate ESL Listening/Speaking II**

**Advisory:** ESL 531 or ESL Assessment Recommendation. Recommended concurrent enrollment in ESL 542 and 543.

**Transferable:** No

This course expands listening and speaking skills through extended listening exercises, open-ended dialogues, pair and group discussions, oral interviews, and oral reports. Students broaden vocabulary while listening to and speaking in both formal and informal, conversational and academic situations.

4395	L/L	HU104	SANIDAD M	6.00	4.0	DAILY	0810A-0900A	
------	-----	-------	-----------	------	-----	-------	-------------	--

**ESL 542 Intermediate ESL Reading/Vocabulary II**

**Advisory:** ESL 532 or ESL Assessment Recommendation. Recommended concurrent enrollment in ESL 541 and 543.

**Transferable:** No

This course begins the expansion of reading skills and vocabulary development through the application of different reading strategies to a variety of selections on topics of interest to academically-bound students including selections from literature.

4396	L/L	LI100	LAWN B	6.00	4.0	MWF	1110A-1200P	
------	-----	-------	--------	------	-----	-----	-------------	--

**ESL 543 Intermediate ESL Grammar/Writing II**

**Prerequisite:** ESL 533 with a grade of C or better or ESL assessment recommendation.

**Corequisite:** Recommended concurrent enrollment in ESL 541 and ESL 542.

**Transferable:** No

This course is a continuation of ESL 533. Units earned in this course do not count toward the associate degree and/or certain certificate requirements.

4397	L/L	LI100	LAWN B	6.00	4.0	DAILY	0910A-1000A	
------	-----	-------	--------	------	-----	-------	-------------	--

**ESL 546 Introduction to Computers for ESL Students**

**Advisory:** CSIS 122. Eligible for Gavilan College ESL Program Intermediate.

**Transferable:** No

Introduction to basic computer hardware functions and terminology; overview of Windows operating environment and word processing for ESL students.

4398	L/L	BU119	SANIDAD M	2.00	1.0	MW	1210P-0100P	02/13/06 - 04/12/06
------	-----	-------	-----------	------	-----	----	-------------	---------------------

Sect.	Type	Room	Instructor	Hrs.	Units	Days	Begin-End	Footnotes
-------	------	------	------------	------	-------	------	-----------	-----------

**ESL 552 Advanced ESL Reading/Vocabulary I**

**Advisory:** ESL 542 or ESL Assessment Recommendation. Recommended concurrent enrollment in ESL 553 and/or ESL 555.

**Transferable:** No

This course focuses on academic and critical thinking skills needed to increase reading comprehension and efficiency. Emphasis is on analyzing, making inferences, taking notes, supporting opinions, summarizing and expanding vocabulary. Readings are from academic texts and literature.

4399	LEC	HU101	WEXLER L	4.00	4.0	MTuWTh	1110A-1200P	
------	-----	-------	----------	------	-----	--------	-------------	--

**ESL 553 Advanced ESL Composition I**

**Prerequisite:** ESL 543 with a grade of C or better or ESL Assessment Test recommendation.

**Corequisite:** Recommended concurrent enrollment in ESL 552 and ESL 555.

**Transferable:** No

This course is a composition course for ESL students that develops college composition skills through a review of the parts and elements of the English paragraph and an introduction to the essay form. The course focuses on the development of a paragraph and expands to the writing of multiple paragraphs in an essay. Basic rhetorical patterns and methods of organization are covered using the multiple-draft approach to writing.

4400	L/L	HU104	SANIDAD M	6.00	4.0	DAILY	1010A-1100A	
------	-----	-------	-----------	------	-----	-------	-------------	--

**ESL 555 Advanced ESL Grammar**

**Prerequisite:** ESL 543 with a grade of C or better or ESL Assessment Test Recommendation.

**Advisory:** Recommended concurrent enrollment in ESL 553 and ESL 552.

**Transferable:** No

This course is designed to help students improve their grammar usage so that they will be able to succeed in English composition courses. Students will enhance their writing skills by practicing with previously encountered basic structures as well as newly acquired more sophisticated ones.

4401	L/L	LI100	BAAMEURK	6.00	4.0	DAILY	0810A-0900A	
------	-----	-------	----------	------	-----	-------	-------------	--

**ESL 556 Information Competency for ESL Students**

**Advisory:** ESL 546

**Transferable:** No

This class will provide an introduction to basic information competency skills designed especially for the ESL student. Students will get an overview of basic terminology, various formats of information, how information is stored and organized, plus hands-on experience with online catalogs and databases. They will also learn and practice basic search strategies and evaluation skills. This is a credit/no credit course. This course is also listed as LIB 556.

4763	LEC	BU119	MCMAMARA R	1.00	1.0	F	0910A-1005A	11 01/27/06 - 05/19/06
------	-----	-------	------------	------	-----	---	-------------	---------------------------

**ESL 561 Advanced ESL Communication Skills**

**Advisory:** ESL 552 and ESL 553 or ESL Assessment Test recommendation. Recommended concurrent enrollment in ESL 562 and 563.

**Transferable:** No

This course is designed to help non-native students mainstream into regular college courses. Its purpose is to prepare for full class participation with emphasis on exposure to and awareness of a variety of instructional formats, note-taking techniques, discussions, and oral presentations.

4402	LEC	HU104	WEXLER L	3.00	3.0	MWTh	0910A-1000A	
------	-----	-------	----------	------	-----	------	-------------	--

**ESL 562 Advanced ESL Reading/Vocabulary II**

**Advisory:** ESL 552 or ESL Assessment recommendation. Recommended concurrent enrollment in ESL 563.

**Transferable:** No

This course prepares ESL students for mainstream college classes by reviewing a variety of reading skills, strategies, and topics from different academic disciplines. Students expand their academic vocabulary and read short stories or a novel for literary appreciation.

4403	LEC	OE001	CAMPBELL K	4.00	4.0	MTuThF	0810A-0900A	
------	-----	-------	------------	------	-----	--------	-------------	--

**ESL 563 Advanced ESL Composition II**

**Prerequisite:** ESL 553 with a grade of "C" or better or ESL Assessment Test recommendation.

**Advisory:** Recommended concurrent enrollment in ESL 561.

**Transferable:** No

This course which is designed for ESL students, refines and further expands college composition skills through the writing of essays using the multiple-draft approach to writing. The course focuses on the structuring and development of an essay with the use of personal examples and/or outside sources. Students write in response to a variety of prompts and viewpoints on issues using different rhetorical patterns, and they are introduced to writing tasks used in academic disciplines other than English.

4404	L/L	HU104	BAAMEURK	6.00	4.0	DAILY	1110A-1200P	
------	-----	-------	----------	------	-----	-------	-------------	--

## The Final Word!

Look for the Final Exams schedule on page 110 of this schedule.

Sect. Type Room Instructor Hrs. Units Days Begin-End Footnotes

**Film: See HUM 3, 4, 10****Foreign Language: See Spanish (SPAN) & Japanese (JPN)****Geography: See also CSIS 61 - Geographic Information Systems****GEOGRAPHY****GEOG 1 Physical Geography****Advisory:** Eligible for English 250 and English 260.**Transferable:** CSU; UC; CSU-GE: B1, B3; IGETC: 5A; GAV-GE: B1, B3; CAN: GEOG 2

An introductory study of the basic physical elements of geography including climate, land forms, soils, water, and natural vegetation. The laboratory will include the tools and methods of geographers.

4407 L/L HOL4 WILLAHAND 5.00 3.0 MW 0900A-1125A

**Above class meets at the Hollister Briggs site****GEOG 2 Cultural Geography****Advisory:** Skills commensurate with successful completion of English 250 and English 260 or equivalent.**Transferable:** CSU; UC; CSU-GE: D5; IGETC: 4E; GAV-GE: D2, F; CAN: GEOG 4

A survey of human geography including historical geography; geographical techniques and methodology; social, economic and political geography; demographic studies; distribution of language and religions; folk vs. popular culture; agriculture, industry, and globalism. This course has the option of a letter grade or credit/no credit.

4409 LEC MHG4 BUMGARNER M 3.00 3.0 MW 0900A-1015A

**Above class meets at the Morgan Hill Community Center site****GEOLOGY****GEOL 1 Introduction to Geology****Advisory:** Eligible for English 250 and English 260.**Transferable:** CSU; UC; CSU-GE: B1, B3; IGETC: 5A; GAV-GE: B1, B3; CAN: GEOL 2

A study of the earth and the physical properties which modify the earth; minerals, rocks, geologic structures and processes.

4410 L/L CH102 WILLAHAND 6.00 4.0 MW 1245P-0335P 1

**Government: See Political Science****Graphic Arts: See Art, CSIS****GUIDANCE****GUID 1 Self-Assessment and Career Development****Advisory:** Eligible for English 250 and English 260.**Transferable:** CSU; CSU-GE: E2; GAV-GE: E2

This course is designed to assist the student in learning more about personal values, personality, interests, exploration of career choice, and occupational opportunities through the use of various personal assessment instruments. The delivery options for this course also include online and self-paced formats. This course is also listed as PSYC 5.

4416 ONLINE STAFF 4.00 2.0 DHR 0000-0000 25 38 89

03/6/06 - 05/5/06

**This online class will be delivered entirely over the internet. After enrolling, start the class by going to <http://www.gavilan.edu/disted/>, click on your class link, and email the instructor at [jostewart@gavilan.edu](mailto:jostewart@gavilan.edu). Students who have not begun the class or contacted the instructor by 5 pm on March 11 will be dropped from the class.****For additional GUID 1 options see the Learning Community section - page 74.**

Sect. Type Room Instructor Hrs. Units Days Begin-End Footnotes

**GIS****Geographic Information Systems****CSIS 61**

Section 6060

What do Administration of Justice, Biology, Business, Ecology, Economics, Geography, Geology, History, Landscaping, Public Health, Urban Planning, and Zoology have in common?

**They all use GIS!**

Take this class on Wednesday evenings in Morgan Hill.

**Faculty! Staff! Students!  
Working Parents! Community!****Do you need child care while you are  
teaching, learning or working?****FEE-BASED  
SERVICE!**

Ages: 6 weeks - 5 years

Gavilan's Child Development Center will accept payment from other subsidized programs (i.e., 4C's, Choices for Children)

Personal payment also accepted.  
NAEYC accredited.**6:30 a.m. - 6:00 p.m.**

Call the Child Development Center at 408-848-4815 for more information.

**Gavilan College's own  
educational TV station****Gav TV Channel****18**



Sect.	Type	Room	Instructor	Hrs.	Units	Days	Begin-End	Footnotes
-------	------	------	------------	------	-------	------	-----------	-----------

### GUIDANCE - PUENTE

The Puente Project is a two-semester program that combines three components: writing, counseling and mentoring to support students to transfer to four-year universities and colleges. The Guidance 1 course focuses on self-assessment and career development. The English 1A course focuses on Mexican-American Latino literature. The program is open to all eligible students. For more information, call Celia Marquez, Puente Co-Coordinator at 408-848-4807.

#### **GUID 1 Self-Assessment and Career Development**

4413	LEC	CH102	MARQUEZ C	2.00	2.0	MW	1110A-1200P	50 82 89
------	-----	-------	-----------	------	-----	----	-------------	----------

#### **ENGL 1A Composition**

**Prerequisite:** English 250 and English 260 with a grade of 'C' or better or satisfactory score on the English placement examination.

4296	LEC	HU103	CANDELARIA X	3.00	3.0	TuTh	1110A-1225P	1 82
------	-----	-------	--------------	------	-----	------	-------------	------

### GUIDANCE - FIRST YEAR EXPERIENCE

#### **Starting your first semester at Gavilan?**

Then this learning community program is specially designed for you.

The first year of college can be challenging for many students. By studying and working together with your classmates and instructors, in this program you'll develop a strong network of support to help you succeed. You'll improve your reading and writing skills and also explore options for majors, transferring, and careers. Building a strong foundation in your first year will put you on the road to success throughout your college experience.

#### **The Program:**

Students will take reading, writing and guidance together because these skills are needed to succeed in college classes.

**The following classes are part of a First Year Experience-learning community. You must enroll in all three courses.**

#### **GUID 1 Self-Assessment and Career Development**

4411	LEC	HU104	GODLEY J	2.00	2.0	F	0910A-1100A	85 89
------	-----	-------	----------	------	-----	---	-------------	-------

#### **ENGL 250 Practical Writing**

**Prerequisite:** English 440 or ESL 563 with a grade of 'C' or better or satisfactory score on the English placement examination.

4345	L/L	CH102	HULL K	4.00	3.0	TuTh	1110A-1225P	118 85
		SS203	HULL K			Tu	0835A-0925A	

#### **ENGL 260 Preparation for College Reading**

**Prerequisite:** Completion of English 420 or Assessment recommendation.

4354	LEC	CH102	HOOPER J	3.00	3.0	TuTh	0945A-1100A	1 85
------	-----	-------	----------	------	-----	------	-------------	------

**The following classes are part of a First Year Experience-learning community. You must enroll in all three courses.**

#### **GUID 1 Self-Assessment and Career Development**

4412	LEC	HU104	GODLEY J	2.00	2.0	F	0910A-1100A	85 89
------	-----	-------	----------	------	-----	---	-------------	-------

#### **ENGL 250 Practical Writing**

**Prerequisite:** English 440 or ESL 563 with a grade of 'C' or better or satisfactory score on the English placement examination.

4346	L/L	CH102	HULL K	4.00	3.0	TuTh	1110A-1225P	118 85
		SS203	HULL K			Th	0835A-0925A	

#### **ENGL 260 Preparation for College Reading**

**Prerequisite:** Completion of English 420 or Assessment recommendation.

4355	LEC	CH102	HOOPER J	3.00	3.0	TuTh	0945A-1100A	1 85
------	-----	-------	----------	------	-----	------	-------------	------

Sect.	Type	Room	Instructor	Hrs.	Units	Days	Begin-End	Footnotes
-------	------	------	------------	------	-------	------	-----------	-----------

**The following classes are part of a First Year Experience-learning community. You must enroll in all three courses.**

#### **GUID 1 Self-Assessment and Career Development**

4414	LEC	SS206	WHITNEY C	2.00	2.0	F	1110A-0100P	85 89
------	-----	-------	-----------	------	-----	---	-------------	-------

#### **ENGL 250 Practical Writing**

**Prerequisite:** English 440 or ESL 563 with a grade of 'C' or better or satisfactory score on the English placement examination.

4347	L/L	SS203	HULL K	4.00	3.0	TuTh	1245P-0200P	118 85
		LI171	HULL K			Tu	0210P-0300P	

#### **ENGL 260 Preparation for College Reading**

**Prerequisite:** Completion of English 420 or Assessment recommendation.

4356	LEC	SS203	HOOPER J	3.00	3.0	TuTh	1110A-1225P	1 85
------	-----	-------	----------	------	-----	------	-------------	------

**The following classes are part of a First Year Experience-learning community. You must enroll in all three courses.**

#### **GUID 1 Self-Assessment and Career Development**

4415	LEC	SS206	WHITNEY C	2.00	2.0	F	1110A-0100P	85 89
------	-----	-------	-----------	------	-----	---	-------------	-------

#### **ENGL 250 Practical Writing**

**Prerequisite:** English 440 or ESL 563 with a grade of 'C' or better or satisfactory score on the English placement examination.

4348	L/L	SS203	HULL K	4.00	3.0	TuTh	1245P-0200P	118 85
		LI171	HULL K			Th	0210P-0300P	

#### **ENGL 260 Preparation for College Reading**

**Prerequisite:** Completion of English 420 or Assessment recommendation.

4357	LEC	SS203	HOOPER J	3.00	3.0	TuTh	1110A-1225P	1 85
------	-----	-------	----------	------	-----	------	-------------	------

### GUIDANCE - continued

#### **GUID 22 Field Work and Service**

**Required:** Learning contracts must be filled out and signed by the student and the supervising instructor.  
**Transferable:** CSU

Supervised field work within the college and with local agencies. Students serve in useful group activities in leadership roles prescribed for them by faculty or community agencies. A maximum of six units may be completed. This is a credit/no credit course.

4417	FEX	LI117	EASTMAN B	3.00	1.0	DHR	0000-0000	22 73
------	-----	-------	-----------	------	-----	-----	-----------	-------

#### **GUID 28 Tutoring Techniques**

**Advisory:** English 250.

**Transferable:** CSU

This course is designed to train students in effective tutoring skills, introduction to how people learn, teaching to modalities, and techniques of working with student anxiety. This course has the option of a letter grade or credit/no credit.

4418	LEC	SS111	RODERICK D	3.00	1.0	F	0110P-0245P	11 19 37
		LI116	RODERICK D			S	0930A-0125P	

**02/24/06 - 04/07/06** This class meets Fridays, February 24 – April 7, 2006. There is only ONE Saturday meeting (March 11, 2006) that will meet in LI 116.

#### **GUID 29 Tutoring Lab**

**Advisory:** Completion of, or concurrent enrollment in Guidance 28.

**Transferable:** CSU

This course will allow students to gain valuable experience in the field of teaching. Students will practice the skills they have learned in Guidance 28. Guidance 29 may be repeated for a maximum of 2.0 units per semester and a maximum course total of 8.0 units. This is a credit/no credit course.

4419	LAB	LI116	RODERICK D	3.00	1.0	DHR	0000-0000	73
4420	LAB	LI116	RODERICK D	6.00	2.0	DHR	0000-0000	73

#### **GUID 250 Supervised Tutoring**

Laboratory class emphasizing college learning skills, appropriate study techniques, and learning assistance utilizing one-on-one or small group tutorial.

Students accessing services in a learning support lab will be automatically enrolled in the appropriate noncredit Guidance 250 section. GUID 250 is a noncredit class and will not appear on a student's transcript.

Sect.	Type	Room	Instructor	Hrs.	Units	Days	Begin-End	Footnotes
-------	------	------	------------	------	-------	------	-----------	-----------

**GUID 530 Job Readiness****Transferable:** No

This course is designed to provide a comprehensive, well-organized approach to assist individuals with the identification of occupational choices and the development of job readiness skills necessary to obtain and maintain employment in a competitive or supported work setting. May be repeated twice for credit. This course has the option of a letter grade or credit/no credit.

4432	LAB	BU117	FRANKLINL	3.00	3.0	TuTh	0810A-0925P	75
------	-----	-------	-----------	------	-----	------	-------------	----

**GUID 557 Learning Skills Assessment****Transferable:** No

This course provides an assessment of the students' cognitive/perceptual abilities and basic skills academic achievement. The assessment results are used to determine the students' eligibility for Learning Disabilities Services, to develop individual educational plans, and/or to improve the students' understanding of their own learning strengths and weaknesses. The assessment is conducted on a one-to-one basis by appointment. Units earned in this course do not count toward the associate degree and/or certificate requirements. This is a credit/no credit course.

4433	LAB	L117	FRIEDMAN M ALSTER E	1.00	.5	Day/Time -	see instructor	231
------	-----	------	------------------------	------	----	------------	----------------	-----

**GUID 558 Learning Skills Laboratory****Advisory:** Completion of Guidance 557 or demonstrated academic deficit.**Transferable:** No

The Learning Skills Laboratory is designed to assist students who are eligible to receive Learning Disabilities Services and/or have demonstrated academic deficits. The course content is individualized and based on Individual Educational Plans and Educational Contracts which are developed for each student. Students receive supplemental instruction, academic support, and learning strategy suggestions appropriate for their individual cognitive, perceptual, and academic strengths and weaknesses. Units earned do not count towards the associated degree and/or certificate requirements. This is a credit/no credit course.

4434	LAB	L116	FRIEDMAN M ALSTER E	3.00	1.0	Day/Time -	see instructor	1231
------	-----	------	------------------------	------	-----	------------	----------------	------

4435	LAB	L116	FRIEDMAN M ALSTER E	6.00	2.0	Day/Time -	see instructor	1231
------	-----	------	------------------------	------	-----	------------	----------------	------

4436	LAB	L116	FRIEDMAN M ALSTER E	1.50	.5	Day/Time -	see instructor	1231
------	-----	------	------------------------	------	----	------------	----------------	------

**GUID 561 Writing Skills****Advisory:** Completion of Guidance 557 or demonstrated deficit in written language achievement.**Transferable:** No

This course is designed to teach basic writing skills to students who have demonstrated difficulty mastering written language and who are eligible to receive Learning Disability Services. Material is presented in a concrete, multi-sensory manner, and the class includes opportunity for immediate practice, repetition, and review. The course content includes grammar, sentence structure, and punctuation. Units earned do not count toward the associate degree and/or certificate requirements.

4437	L/L	BU117	MARINGER J	2.00	1.0	TuTh	1010A-1100A	12
------	-----	-------	------------	------	-----	------	-------------	----

**GUID 562 Directed Study Lab in Arithmetic****Corequisite:** Concurrent enrollment in MATH 400.**Advisory:** Completion of GUID 557 and/or a demonstrated deficit in arithmetic.**Transferable:** No

This course is designed for students who have demonstrated difficulty in mastering arithmetic and who are eligible to receive Learning Disability Services. Course content parallels Mathematics 400. Material is presented in a concrete, multi-sensory manner, and the lab allows opportunity for immediate practice, questions, repetition, and review. Units earned do not count toward the associate degree and/or certificate requirements. This is a credit/no credit course.

4438	LAB	BU117	BURGMANL	3.00	1.0	MW	0945A-1100A	12
------	-----	-------	----------	------	-----	----	-------------	----

**GUID 563B Directed Study Lab in Algebra****Corequisite:** Concurrent enrollment in MATH 205B is required.**Advisory:** Completion of GUID 557 or demonstrated deficit in mathematics.**Transferable:** No

This course is designed for students who have demonstrated difficulty mastering elementary algebra and who are eligible to receive Learning Disability Services. Course content parallels Mathematics 205B. Material is presented in a concrete, multi-sensory manner, and the lab allows opportunity for immediate practice, questions, repetition, and review. This is a credit/no credit course.

4439	LAB	SS216	FRIEDMAN M	4.00	1.0	MW	1110A-1225P	12
------	-----	-------	------------	------	-----	----	-------------	----

Sect.	Type	Room	Instructor	Hrs.	Units	Days	Begin-End	Footnotes
-------	------	------	------------	------	-------	------	-----------	-----------

**FACULTY Profile****LEAH HALPER:**

I earned my B.A. in History and English at Stanford University, and then an M.A. in Journalism at New York University, with graduate coursework in Education at University of the Pacific. Before joining the faculty at Gavilan College, I was a newspaper journalist. I have been teaching for sixteen years, and have had a number of other experiences as well: former grievance officer for the National Writers' Union, former Gilroy Library Commissioner, peace activist, environmental educator, and mediator with the Santa Clara County Office of Human Relations. This year I am serving as the secretary of the Gavilan College Faculty Association. In my spare time I am playwright and essayist!

I hope that students in my classes will get enough of a context so they understand how quickly fascism and chaos can occur, how patiently social change must be built, and how important they are to the future of the planet.

Sect.	Type	Room	Instructor	Hrs.	Units	Days	Begin-End	Footnotes
<b>GUID 564</b>	<b>Directed Study Lab in Pre-Algebra</b>							
<b>Corequisite:</b> Concurrent enrollment in MATH 402.								
<b>Advisory:</b> Completion of Guidance 557 and/or a demonstrated deficit in Mathematics.								
<b>Transferable:</b> No								
This course is designed for students who are eligible to receive Learning Disability Services and/or who have demonstrated difficulty in mastering pre-algebra. The course content parallels Mathematics 402. The material is presented in a concrete, multi-sensory manner, and the lab environment allows opportunity for immediate practice questions, repetition and review. Units earned do not count towards the associate degree and/or certificate requirements. This is a credit/no credit course.								
4440	L/L	BU117	BURGMAN,L	3.00	1.0	MW	1245P-0200P	12

## HEALTH EDUCATION

### HE 1 Health Education

**Advisory:** Eligible for English 250 and English 260.

**Transferable:** CSU; UC; CSU-GE: E2; GAV-GE: E2

This course focuses on attaining individual awareness, critical-thinking skills and self-responsibility relating to personal health. The interaction of individual physical, psychological, social, emotional, spiritual and environmental factors in determining health status is developed through integration of major concepts. This course has the option of a letter grade or credit/no credit.

4441	LEC	LS104	DODD S	3.00	3.0	TuTh	0945A-1100A
------	-----	-------	--------	------	-----	------	-------------

## HISTORY

### HIST 1 United States History through Reconstruction

**Advisory:** Eligible for English 250 and English 260.

**Transferable:** CSU; UC; CSU-GE: C2, D6; IGETC: 3B, 4F, 7B; GAV-GE: C2, D2; CAN: HIST 8, HIST SEQ. B

History of the United States from the time before European contact with the Americas through Reconstruction. Emphasis will be placed on distinctive patterns of political, economic, social, intellectual, and geographic developments within their global context. At the conclusion of the course, the student should understand major themes in the history of the United States, and be able to explain various ways in which ideas about federal vs. state power, ethnicity, class, and gender divisions have influenced the nation's development. This course has the option of a letter grade or credit/no credit.

4442	LEC	SS205	WOOD D	3.00	3.0	TuTh	0810A-0925A
4443	LEC	SS214	HALPER L	3.00	3.0	MW	0945A-1100A
4444	LEC	SS210	LUNA E	3.00	3.0	TuTh	0945A-1100A
4445	LEC	SS210	HALPER L	3.00	3.0	MW	1245P-0200P
4446	LEC	SS210	LUNA E	3.00	3.0	TuTh	0215P-0330P
4752	LEC	LOHS	STAFF	3.00	3.0	M	0315P-0605P

**Above class meets at Live Oak High School, rm. 903**

6104	LEC	SS205	HALPER L	3.00	3.0	Tu	0630P-0920P
------	-----	-------	----------	------	-----	----	-------------

### HIST 2 United States History Reconstruction to the Present

**Advisory:** Eligible for English 250 and English 260.

**Transferable:** CSU; UC; CSU-GE: C2, D6; IGETC: 3B, 4F, 7B; GAV-GE: C2, D2; CAN: HIST 10, HIST SEQ. B

History of the United States from Reconstruction to the present. Emphasis will be placed on distinctive patterns of political, economic, social, intellectual, and geographic developments within their global context. At the conclusion of the course, the student should understand major themes in the history of the United States, and be able to explain various ways in which ideas about federal vs. state power, ethnicity, class, and gender divisions have influenced the nation's development. This course has the option of a letter grade or credit/no credit.

4447	LEC	MHG10	KIER D	3.00	3.0	MW	0900A-1015A
------	-----	-------	--------	------	-----	----	-------------

**Above class meets at Morgan Hill Community site**

4448	LEC	SS210	WOOD D	3.00	3.0	TuTh	1110A-1225P
------	-----	-------	--------	------	-----	------	-------------

4449	LEC	SS210	HALPER L	3.00	3.0	TuTh	1245P-0200P
------	-----	-------	----------	------	-----	------	-------------

6105	LEC	HOL2	LUNA E	3.00	3.0	W	0630P-0920P
------	-----	------	--------	------	-----	---	-------------

**Above class meets at the Hollister Briggs site**

## For on-campus child care

contact the Child Development Center at (408) 848-4815

Sect.	Type	Room	Instructor	Hrs.	Units	Days	Begin-End	Footnotes
<b>HIST 6</b>	<b>Women's Lives in Recent United States History</b>							
<b>Advisory:</b> English 250								
<b>Transferable:</b> CSU; UC; CSU-GE: C2, D4; IGETC: 3B, 4F; GAV-GE: C2, D2								
A Survey of United States Women's history from 1900 to the present with emphasis on the contributions of individual women and groups of women. Social, political, economic and cultural forces affecting women's public and private roles will be examined. This course has the option of a letter grade or credit/no credit.								
4450	LEC	SS110	WOOD D	3.00	3.0	TuTh	0945A-1100A	

### HIST 7B History of Western Civilization

**Advisory:** Eligible for English 250 and English 260.

**Transferable:** CSU; UC; CSU-GE: C2; IGETC: 3B; GAV-GE: C2; CAN: HIST 4, HIST SEQ. A

A study of major elements in western heritage from Renaissance Europe to the present. Emphasis is on ideas, attitudes and institutions basic to western civilization of enduring interest.

4451	LEC	MHG10	KIER D	3.00	3.0	MW	1030A-1145A
------	-----	-------	--------	------	-----	----	-------------

**Above class meets at Morgan Hill Community site**

### HIST 12 Cultural History of the Mexican American

**Advisory:** Eligible for English 250 and English 260.

**Transferable:** CSU; UC; CSU-GE: D6, D3, C2; IGETC: 4F, 3B; GAV-GE: D2,

The Mexican American experience as influenced by society in the United States. Emphasis will be on the historical and contemporary contributions made by the Indian, Spanish, Mexican, and Mexican American. Emphasis will also be on the social, economic, and political milieu of the Mexican American within the context of the American society. This course has the option of a letter grade or credit/no credit.

4452	LEC	SS210	LUNA E	3.00	3.0	MW	1110A-1225P
------	-----	-------	--------	------	-----	----	-------------

### HIST 21 Ancient Americas: A History through Art

**Advisory:** Eligible for English 250.

**Transferable:** CSU; UC; CSU-GE: C2; IGETC: 3A; GAV-GE: C2, F

A critical survey of history through the arts of pre-Columbian natives of North, Central and South America. The course will cover major societies and events from the appearance of major civilizations through the initial colonization efforts of European nations. Due to the distinct history of the Americas, this course uses the arts - architecture, sculpture, ceramics and painting, among others - of ancient societies as a primary source material. This course has the option of a letter grade or credit/no credit. This course is also listed as ART 21.

4453	LEC	SS111	LUNA E	3.00	3.0	MW	1245P-0200P
------	-----	-------	--------	------	-----	----	-------------

## HUMANITIES



### HUM 4 Introduction to American Cinema

**Advisory:** English 440

**Transferable:** CSU; UC; CSU-GE: C2; IGETC: 3B; GAV-GE: C2

This introductory course in film studies is a survey of the American film industry as an art form, as an industry, and as a system of representation and communication. The course explores how Hollywood films work technically, aesthetically, and culturally to reinforce and challenge America's national self-image.

6106	TV	SS214	RICHARDS G	3.00	3.0	W	0700P-0950P	60
------	----	-------	------------	------	-----	---	-------------	----

**Course delivery is through Gavilan Channel 18, Morgan Hill MCHAT Channel 18 or video tape (\$25 refundable security deposit required.) This telecourse will have three required on-campus meetings, Wednesdays, January 25, March 22 and May 24, 2006. Orientation for the course will be provided at the first class meeting.**

### HUM 10 Approaches to Contemporary Film

**Advisory:** Eligibility for English 250 and 260.

**Transferable:** CSU; UC; CSU-GE: C1, C2; IGETC: 3B; GAV-GE: C1, C2

Approaches to Contemporary Film examines theories of film criticism as they apply to films from 1960 to the present. Students learn technical, visual, classical, historical, cultural, ideological, and aesthetic approaches to film and sample from a representative list of foreign and domestic movies. Special emphasis is given to new voices from non-American sources and to emerging voices in American cinema.

4454	LEC	SS214	RICHARDS G	3.00	3.0	TuTh	1110A-1225P
------	-----	-------	------------	------	-----	------	-------------

4455	LEC	SS214	RICHARDS G	3.00	3.0	MW	1245P-0200P
------	-----	-------	------------	------	-----	----	-------------

Sect.	Type	Room	Instructor	Hrs.	Units	Days	Begin-End	Footnotes
-------	------	------	------------	------	-------	------	-----------	-----------

**HUM 23 Independent Study**

**Required:** The study outline prepared by the student and the instructor must be filed with the department and the dean.

**Transferable:** CSU

Designed to afford selected students specialized opportunities for exploring areas at the independent study level. The courses may involve extensive library work, research in the community, or special projects. May be repeated until six units of credit are accrued. This course has the option of a letter grade or credit/no credit.

4456	IND	HU111	RICHARDS G	3.00	1.0	DHR	0000-0000	22
------	-----	-------	------------	------	-----	-----	-----------	----

**Information Science: See CSIS**

**JAPANESE****JPN 1A Elementary Japanese**

**Transferable:** CSU; UC; GAV-GE: C2

Beginning course with emphasis on understanding and speaking Japanese; introduction to reading and writing Japanese. This course will also introduce students to Japanese culture and institutions. This course has the option of a letter grade or credit/no credit.

4527	L/L	SS205	SAKAIT	7.50	5.0	MW&2.5	0210P-0420P	20
------	-----	-------	--------	------	-----	--------	-------------	----

**JPN 1B Elementary Japanese**

**Prerequisite:** Japanese 1A or equivalent.

**Transferable:** CSU; GAV-GE: C2

Continue Japanese 1A with an emphasis on understanding, speaking, reading, and writing Japanese. This course will continue to introduce students to Japanese culture and institutions. This course has the option of a letter grade or credit/no credit.

4528	L/L	SS214	SAKAIT	7.50	5.0	MW&2.5	1110A-0120P	20
------	-----	-------	--------	------	-----	--------	-------------	----

**JOURNALISM****JOUR 10 Mass Media and Society**

**Advisory:** English 250, English 260.

**Transferable:** CSU; UC; CSU-GE: C2, D0; IGETC: 4J; GAV-GE: C2, D2; CAN: JOUR 4

This course helps students understand the 20th century revolution in mass media by focusing on the history, economics and social impact of the newspaper, book publishing, magazine, film, television, public relations, advertising and music industries. Students will study audience, propaganda and mass communication theory; and discuss new technology, ethnic media in the United States, ethical issues and attempts to regulate or control the media. Honors students will complete more in-depth analysis of media issues and will finish a media-related research project. This course is also listed as SOC 10. This course has the option of a letter grade or credit/no credit.

4503	LEC	SS205	STAFF	3.00	3.0	TuTh	0215P-0330P	
------	-----	-------	-------	------	-----	------	-------------	--

**JOUR 16A Writing for Media**

**Advisory:** Typing skill; English 1A eligibility.

**Transferable:** CSU; GAV-GE: C1; CAN: JOUR 2

Fundamentals of journalistic writing and analysis of news values and news writing. Stresses organization and structure of news stories; the language and style of news writing; the basic lead and story types for print and broadcast media.

4504	L/L	HU106	GUERRAZZI D	4.00	3.0	MW&1	0945A-1100A	
------	-----	-------	-------------	------	-----	------	-------------	--

**JOUR 18A Working on the Newspaper**

**Advisory:** Eligible for English 1A. Typing ability.

**Transferable:** CSU; GAV-GE: C1

Students interview, write, photograph and do computer assisted design and graphics for the college newspaper, the Rambler. In doing this, they provide the community with an important first amendment forum, learn and educate about the first amendment rights and responsibilities, and acquire journalistic skills, ethics, and habits.

4505	L/L	HU106	GUERRAZZI D	2.00	2.0	MW	1110A-1225P	1
4506	L/L	HU106	GUERRAZZI D	5.00	3.0	MW&2	1110A-1225P	1
4507	L/L	HU106	GUERRAZZI D	8.00	4.0	MW&5	1110A-1225P	1
4508	L/L	HU106	GUERRAZZI D	11.00	5.0	MW&8	1110A-1225P	1

Sect.	Type	Room	Instructor	Hrs.	Units	Days	Begin-End	Footnotes
-------	------	------	------------	------	-------	------	-----------	-----------

**FACULTY Profile****TOSHIO SAKAI:**

I received my undergraduate degree at a university in Tokyo, Japan, then did graduate and post-graduate studies in religion and theology in the U.S. I spent many years as a pastor at Japanese-American churches prior to becoming a teacher of the Japanese language. I have been teaching for fifteen years and have taught in High Schools, at the Defense Language Institute, DeAnza College, UCSC Extension, and Hartnell College. I have published many articles in Japanese journals and newspapers on the topics of American religion, politics and culture. I would like to see students gain knowledge and understanding of the Japanese language and culture so that their view of life and experience as a whole will be enriched.

**Take the Telecourse**

Course delivery is through Gavilan Channel 18 or video tape.

**Introduction to American Cinema HUM 4**

Choose films from categories such as:

- Musical
- War
- Film Noir
- Western
- Comedy
- Adventure
- Fantasy/Horror
- Silent
- Suspense & Intrigue

sect. 6106  
Wed 7-9:50pm  
SS214

This class fulfills your CSU & IGETC transfer requirements.

This telecourse will have three required on-campus meetings, Wednesdays, January 25, March 22 and May 24, 2006. Orientation for the course will be provided at the first class meeting.



Sect.	Type	Room	Instructor	Hrs.	Units	Days	Begin-End	Footnotes
-------	------	------	------------	------	-------	------	-----------	-----------

**JOUR 18B Working on the Newspaper****Advisory:** Journalism 18A.**Transferable:** CSU; GAV-GE: C1

Students interview, write, photograph and do computer assisted design and graphics for the college newspaper, the Rambler. In doing this, they provide the community with an important first amendment forum, learn and educate about the first amendment rights and responsibilities and acquire journalistic skills, ethics and habits.

4509	L/L	HU106	GUERRAZZI D	2.00	2.0	MW	1110A-1225P	1
4510	L/L	HU106	GUERRAZZI D	5.00	3.0	MW&2	1110A-1225P	1
4511	L/L	HU106	GUERRAZZI D	8.00	4.0	MW&5	1110A-1225P	1
4512	L/L	HU106	GUERRAZZI D	11.00	5.0	MW&8	1110A-1225P	1

**JOUR 18C Working on the Newspaper****Advisory:** Journalism 18B.**Transferable:** CSU; GAV-GE: C1

Students interview, write, photograph and do computer assisted design and graphics for the college newspaper, the Rambler. In doing this, they provide the community with an important first amendment forum, learn and educate about the first amendment rights and responsibilities and acquire journalistic skills, ethics and habits.

4513	L/L	HU106	GUERRAZZI D	2.00	2.0	MW	1110A-1225P	1
4514	L/L	HU106	GUERRAZZI D	5.00	3.0	MW&2	1110A-1225P	1
4515	L/L	HU106	GUERRAZZI D	8.00	4.0	MW&5	1110A-1225P	1
4516	L/L	HU106	GUERRAZZI D	11.00	5.0	MW&8	1110A-1225P	1

**JOUR 18D Working on the Newspaper****Advisory:** Journalism 18C.**Transferable:** CSU; GAV-GE: C1

Students interview, write, photograph and do computer assisted design and graphics for the college newspaper, the Rambler. In doing this, they provide the community with an important first amendment forum, learn and educate about the first amendment rights and responsibilities and acquire journalistic skills, ethics and habits.

4517	L/L	HU106	GUERRAZZI D	2.00	2.0	MW	1110A-1225P	1
4518	L/L	HU106	GUERRAZZI D	5.00	3.0	MW&2	1110A-1225P	1
4519	L/L	HU106	GUERRAZZI D	8.00	4.0	MW&5	1110A-1225P	1
4520	L/L	HU106	GUERRAZZI D	11.00	5.0	MW&8	1110A-1225P	1

**JOUR 22 Field Work and Service****Required:** Learning contracts must be filled out and signed by the student and the supervising instructor.**Transferable:** CSU; GAV-GE: C1

Supervised field work within the college and with local agencies. Students serve in useful group activities in leadership roles prescribed for them by faculty or community agencies. A maximum of six units may be completed. This is a credit/no credit course.

4521	FEX	HU107	GUERRAZZI D	3.00	1.0	TBA	0000-0000	21
------	-----	-------	-------------	------	-----	-----	-----------	----

**JOUR 23 Independent Study****Required:** The study outline prepared by the student and the instructor must be filed with the department and the dean.**Transferable:** CSU; GAV-GE: C1

Designed to afford selected students specialized opportunities for exploring areas at the independent study level. The courses may involve extensive library work, research in the community, or special projects. May be repeated until six units of credit are accrued. This course has the option of a letter grade or credit/no credit.

4522	IND	HU106	GUERRAZZI D	6.00	2.0	DHR	0000-0000	22
------	-----	-------	-------------	------	-----	-----	-----------	----

**JOUR 190 Occupational Work Experience/ Journalism****Required:** Enrollment in a minimum of seven (7) units, including Cooperative Work Experience, during regular semesters; enrollment in at least one other class in summer session.**Transferable:** CSU

The application of learned theory, knowledge, and skills to a practical job setting related to the student's educational/occupational goal. Employment must be directly related to the student's college educational/occupational goal. Periodic interviews of the students and employers or their representatives will be required. Each student shall be assisted in the development of individualized performance objectives, toward which the learning experience shall be directed.

4523	WEX	SC154S	KERRL	5.00	1.0	DHR	0000-0000	
4524	WEX	SC154S	KERRL	10.00	2.0	DHR	0000-0000	
4525	WEX	SC154S	KERRL	15.00	3.0	DHR	0000-0000	
4526	WEX	SC154S	KERRL	20.00	4.0	DHR	0000-0000	

Refer to "How to Use This Schedule" on page 36 for classroom locations.

Sect.	Type	Room	Instructor	Hrs.	Units	Days	Begin-End	Footnotes
-------	------	------	------------	------	-------	------	-----------	-----------

**JPA Fire Technology**  
and  
**JPA Law Enforcement**  
see ad below:



**Careers in**

- Law Enforcement • Fire Technology
- Probation Officer • Dispatcher
- Corrections Officer • Juvenile Hall Counselor

Gavilan College is a member of the South Bay Regional Public Safety Training consortium. This consortium is funded by all colleges regionally to provide vocational specific training which may require special facilities, special training conditions or is presented outside of the schedules of regular college classes. For more information call 408-270-6458.

**Law Enforcement: See also - Administration of Justice****LIBRARY****LIB 3 Internet and Information Competency****Advisory:** Eligible for English 250 and 260.**Transferable:** CSU

Research and evaluation skills using the Internet and other electronic resources, as well as traditional printed materials. This six-week course is also listed as CSIS 3. This course has the option of a letter grade or credit/no credit. May be repeated once for credit.

4529	ONLINE	MEADER S	3.00	1.0	TBA	0000-0000	11 25 38
------	--------	----------	------	-----	-----	-----------	----------



**01/03/06 - 02/13/06** This early-start online class will be delivered entirely over the internet. After enrolling, start the class by going to <http://www.gavilan.edu/disted/>, click on your class link, and email the instructor at [smearer@gavilan.edu](mailto:smearer@gavilan.edu). Students who have not begun the class or contacted the instructor by 5 pm on January 12 will be dropped from the class.

**LIB 6 Web Page Authoring I****Advisory:** CSIS 1 or CSIS 2 or CSIS/LIB 3 advised.**Transferable:** CSU; GAV-GE: E2

An introduction to using Hypertext Mark-Up Language (HTML) and Extensible HTML (XHTML) to create web pages which can be unloaded and displayed on the World Wide Web. Students will use HTML/XHTML to create web pages with text in various sizes and colors, links to other sites, background color or patterns, graphics, tables, and mailto links. Principles of design and color as they apply to screen presentations will be included. This course has the option of a letter grade or credit/no credit. May be repeated three times for credit. Also listed as CSIS 6 and DM 6.

4530	ONLINE	HOWELL J	4.00	2.0	DHR	0000-0000	11 25 38
------	--------	----------	------	-----	-----	-----------	----------



**01/03/06 - 03/07/06** This early-start online class will be delivered entirely over the internet. After enrolling, start the class by going to <http://www.gavilan.edu/disted/>, click on your class link, and email the instructor at [jhowell@gavilan.edu](mailto:jhowell@gavilan.edu). Students who have not begun the class or contacted the instructor by 5 pm on January 12 will be dropped from the class.

4531	ONLINE	HOWELL J	4.00	2.0	DHR	0000-0000	11 25 38
------	--------	----------	------	-----	-----	-----------	----------



**03/06/06 - 05/08/06** This online class will be delivered entirely over the internet. After enrolling, start the class by going to <http://www.gavilan.edu/disted/>, click on your class link, and email the instructor at [jhowell@gavilan.edu](mailto:jhowell@gavilan.edu). Students who have not begun the class or contacted the instructor by 5 pm on March 11 will be dropped from the class.

Sect.	Type	Room	Instructor	Hrs.	Units	Days	Begin-End	Footnotes
-------	------	------	------------	------	-------	------	-----------	-----------

### LIB 140 Information Competency for Health Professionals

Transferable: CSU

A beginning course on how to find reliable and current health-related information, using the internet and other electronic resources. Approved for 18 hours of continuing education credit (BRN Provider #00892.) This course is also listed as AH 140.

4532	ONLINE	MEADER S		6.00	1.0	DHR	0000-0000	11 25 38
------	--------	----------	--	------	-----	-----	-----------	----------

**03/06/06 - 04/13/06** This online class will be delivered entirely over the internet. After enrolling, start the class by going to <http://www.gavilan.edu/disted/>, click on your class link, and email the instructor at [smeader@gavilan.edu](mailto:smeader@gavilan.edu). Students who have not begun the class or contacted the instructor by 5 pm on March 11 will be dropped from the class.



### LIB 556 Information Competency for ESL Students

Advisory: ESL 546

Transferable: No

This class will provide an introduction to basic information competency skills designed especially for the ESL student. Students will get an overview of basic terminology, various formats of information, how information is stored and organized, plus hands-on experience with online catalogs and databases. They will also learn and practice basic search strategies and evaluation skills. This is a credit/no credit course. This course is also listed as ESL 556.

4533	LEC	BU119	MCNAMARA R		1.00	1.0	F	0900A-1000A	11 25
------	-----	-------	------------	--	------	-----	---	-------------	-------

**Mass Media: See JOUR 10**

## MATHEMATICS

### MATH 1A Single-Variable Calculus and Analytic Geometry

Prerequisite: Mathematics 10 with a grade of 'C' or better.

Transferable: CSU; UC; CSU-GE: B4; IGETC: 2A; GAV-GE: B4; CAN: MATH 18, MATH SEQ. B

Limits and continuity, analyzing the behavior and graphs of functions, derivatives, implicit differentiation, higher order derivatives, related rates and optimization word problems, Newton's Method, Fundamental Theorem of Calculus, and definite and indefinite integrals.

6115	LEC	PH102	LOCKHART L		4.00	4.0	TuTh	0630P-0820P	1
------	-----	-------	------------	--	------	-----	------	-------------	---

### MATH 1B Single-Variable Calculus and Analytic Geometry

Prerequisite: Mathematics 1A with a grade of 'C' or better.

Transferable: CSU; UC; CSU-GE: B4; IGETC: 2A; GAV-GE: B4; CAN: MATH 20, MATH SEQ. B

This course is a standard second semester Calculus course covering methods of integration, applications of the integral, differential equations, parametric and polar equations, and sequences and series.

4541	LEC	PH102	DACHKOVA E		4.00	4.0	F	0110P-0200P	115
			DACHKOVA E				MW	1245P-0200P	

### MATH 1C Multivariable Calculus

Prerequisite: Mathematics 1B with a grade of 'C' or better.

Transferable: CSU; UC; CSU-GE: B4; IGETC: 2A; GAV-GE: B4; CAN: MATH 22, MATH SEQ. C

A standard third semester Calculus course covering functions of several variables, vectors, surfaces, vector-valued functions, partial derivatives, multiple and line integrals, Green's Theorem, Stokes' Theorem, and the Divergence Theorem.

6116	LEC	PH102	STAFF		4.00	4.0	MW	0630P-0820P	15
------	-----	-------	-------	--	------	-----	----	-------------	----

**Have you met the prerequisite?  
It's required!**

Sect.	Type	Room	Instructor	Hrs.	Units	Days	Begin-End	Footnotes
-------	------	------	------------	------	-------	------	-----------	-----------

## THE WRITING CENTER

CLARITY • CREATIVITY • COMMUNITY

Writing for class?

Writing for fun?

Our trained staff  
can help!



Learn to write more  
powerfully, be creative,  
enjoy writing and practice  
using correct grammar,  
spelling and punctuation.

Meet other poets, fiction writers, journalists and activists.

**Just walk into Library 120**



Monday - Thursday, 8 am - 6 pm, Friday, 8 am - 12:30 pm

Special evening hours - Tuesday - 6-7:30 pm

By appointment only - Thursday - 2-4 pm

**MAKE SOMETHING HAPPEN!  
LEARN SOMETHING NEW!**



### JOUR 16A Writing for Media

*Learn skills that lead to success in other classes*

### JOUR 18A-D Working on the Newspaper

*Become a staff member of the Rambler, Gavilan's independent student newspaper*

Earn units toward a Media Arts Degree • Learn new writing, research and design skills • Get published and build a portfolio of your work • Gain work experience that will help you land a good job

- Become part of a team
- Support free speech at Gavilan College!

**JOUR 16A**  
section 4504 3 units

**JOUR 18A-D**  
sections listed in left column  
2-5 units

Sect.	Type	Room	Instructor	Hrs.	Units	Days	Begin-End	Footnotes
-------	------	------	------------	------	-------	------	-----------	-----------

### MATH 5 Introduction to Statistics

**Prerequisite:** Mathematics 233 with a grade of 'C' or better.

**Transferable:** CSU; UC; CSU-GE: B4; IGETC: 2A; GAV-GE: B4; CAN: STAT 2

Descriptive analysis and presentation of either single-variable data or bivariate data, probability, probability distributions, normal probability distributions, sample variability, statistical inferences involving one and two populations, analysis of variance, linear correlation and regression analysis. Statistical computer software will be extensively integrated as a tool in the description and analysis of data.

4542	LEC	SS206 PH101	DWYER M DWYER M	4.00	3.0	MW F	0945A-1100A 1010A-1100A	1
4543	LEC	PH101 SS206	JUKL H JUKL H	4.00	3.0	TuTh F	1110A-1225P 1110A-1200P	1
4544		ONLINE	HUBBARD M	4.00	3.0	DHR	0000-0000	38

 **This online class will be delivered entirely over the internet. After enrolling, start the class by going to <http://www.gavilan.edu/disted/>, click on your class link, and email the instructor at [mhubbard@gavilan.edu](mailto:mhubbard@gavilan.edu). Students who have not begun the class or contacted the instructor by 5 pm on January 26 will be dropped from the class.**

6117	LEC	HOL2	BATES R	4.00	3.0	Th	0530P-0920P	1
<b>Above class meets at the Hollister Briggs site</b>								
6118	LEC	MHG5 MHG4	VIARENGO A VIARENGO A	4.00	3.0	Tu	0530P-0630P 0630P-0920P	1
<b>Above class meets at Morgan Hill Community site</b>								

### MATH 6 Calculus for Business/Social Science

**Prerequisite:** Mathematics 233 with a grade of 'C' or better.

**Transferable:** CSU; UC; CSU-GE: B4; IGETC: 2A; GAV-GE: B4; CAN: MATH 34

This course applies the fundamental principles and techniques of calculus to problems in business, economics, the life sciences and the social sciences. Topics will include limits, and differentiation and integration of linear, quadratic, polynomial, exponential and logarithmic functions. This course is not intended for students majoring in engineering, the physical sciences or math. Using a calculator is required. Graphing calculator is recommended.

4545	LEC	PH102	LOCKHART L	3.00	3.0	TuTh	0810A-0925A	
------	-----	-------	------------	------	-----	------	-------------	--

**This class The instructor will be using and supporting a TI-83 Plus graphing calculator in all classroom demonstrations.**

### MATH 7 Finite Mathematics

**Prerequisite:** Mathematics 233 with a grade of 'C' or better.

**Transferable:** CSU; UC; CSU-GE: B4; IGETC: 2A; GAV-GE: B4; CAN: MATH 12

Systems of linear equations and matrices, introduction to linear programming, finance, counting techniques and probability, properties of probability and applications of probability.

4546	LEC	PH102	LOCKHART L	3.00	3.0	TuTh	1245P-0200P	115
------	-----	-------	------------	------	-----	------	-------------	-----

### MATH 8A First Half of Precalculus

**Prerequisite:** Mathematics 233 with a grade of 'C' or better.

**Transferable:** CSU; UC; CSU-GE: B4; IGETC: 2A; GAV-GE: B4

Math 8A prepares the student for the study of calculus by providing important skills in algebraic manipulation, interpretation, and problem solving at the college level. Topics will include basic algebraic concepts, complex numbers, equations and inequalities of the first and second degree, functions, and graphs, linear and quadratic equations, polynomial functions, exponential and logarithmic functions, systems of equations, matrices and determinants, right triangle trigonometry, and the Law of Sines and Cosines.

4547	LEC	SS206	WAGMAN K WAGMAN K	4.00	4.0	TuTh F	0945A-1100A 1010A-1100A	115
6119	LEC	PH103	STAFF	4.00	4.0	TuTh	0630P-0820P	115

### MATH 8B Second Half of Precalculus

**Prerequisite:** Mathematics 8A with a grade of 'C' or better.

**Advisory:** Math 208 Survey of Practical Geometry.

**Transferable:** CSU; UC; CSU-GE: B4; IGETC: 2A; GAV-GE: B4

Math 8B prepares students for the study of calculus by providing important skills in algebraic manipulation, interpretation, and problem solving at the college level. Topics will include trigonometric functions, identities, inverse trigonometric functions, and equations; applications of trigonometry, vectors, complex numbers, polar and parametric equations; conic sections; sequences, series, counting principles, permutations, mathematical induction; analytic geometry, and an introduction to limits.

4548	LEC	SS206	JUKL H JUKL H	4.00	4.0	MW F	1245P-0200P 0110P-0200P	15
------	-----	-------	------------------	------	-----	---------	----------------------------	----

Sect.	Type	Room	Instructor	Hrs.	Units	Days	Begin-End	Footnotes
-------	------	------	------------	------	-------	------	-----------	-----------

### MATH 14 Math for the Liberal Arts

**Prerequisite:** Math 233 with a grade of 'C' or better.

**Transferable:** CSU; UC; CSU-GE: B4; IGETC: 2A; GAV-GE: B4

Survey of selected topics from contemporary mathematics to introduce the student to mathematical thinking for the non-specialist. Topics include systems of numeration, algebraic modeling, linear programming, trigonometry, math of finance, probability and statistics, and an introduction to calculus.

6120	LEC	LS102	KERCHEVAL S	3.00	3.0	M	0600P-0850P	1
------	-----	-------	-------------	------	-----	---	-------------	---

### MATH 205 Elementary Algebra

**Prerequisite:** MATH 402 with a grade of 'C' or better or assessment test recommendation.

**Transferable:** No; GAV-GE: B4

This course is a standard beginning algebra course, including algebraic expressions, linear equations and inequalities in one variable, graphing, equations and inequalities in two variables, integer exponents, polynomials, rational expressions and equations, radicals and rational exponents, and quadratic equations. Mathematics 205, 205A and 205B, and 206 have similar course content. This course may not be taken by students who have completed Mathematics 205B or 206 with a grade of "C" or better. This course may be taken for Mathematics 205B credit (2.5 units) by those students who have successfully completed Mathematics 205A with a grade of "C" or better.

4549	LEC	CH109	DWYER M	5.00	5.0	DAILY	0835A-0925A	1
4550	LEC	HOL5	STAFF	5.00	5.0	MTuWTh	1030A-1145A	1

**Above class meets at the Hollister Briggs site**

4551	LEC	MHG13	BUTTERWORTH	5.00	5.0	MTuWTh	0900A-1005A	
<b>Above class meets at Morgan Hill Community site</b>								

4552	LEC	PH103	DACHKOVA E	5.00	5.0	MTuWTh	0945A-1050A	1
4553	LEC	PH103	WAGMAN K	5.00	5.0	MTuWTh	1110A-1215P	1
4554	LEC	CH109	WAGMAN K	5.00	5.0	MTuWTh	1245P-0150P	
6121	LEC	PH103	VIARENGO A	5.00	5.0	M W	0630P-0850P	1
6122	LEC	MHG13	KING K	5.00	5.0	TuTh	0645P-0910P	1
<b>Above class meets at Morgan Hill Community site</b>								

### MATH 205A First Half of Elementary Algebra

**Prerequisite:** Effective Fall 2005: MATH 402 with a grade of 'C' or better or assessment test recommendation.

**Advisory:** Concurrent enrollment in Guidance 563A is advised.

**Transferable:** No; GAV-GE: B4

This course is the first half of the Elementary Algebra course. It will cover signed numbers, evaluation of expressions, ratios and proportions, solving linear equations, and applications. Graphing of lines, the slope of a line, graphing linear equations, solving systems of equations, basic rules of exponents, and operations on polynomials will be covered.

4555	LEC	SS206	BUTTERWORTH BUTTERWORTH	4.00	2.5	TuTh F	1245P-0200P 1210P-0100P	
4759	LEC	SS206	DACHKOVA E DACHKOVA E	4.00	2.5	MW F	1110A-1225P 1110A-1200P	

### MATH 205B Second Half of Elementary Algebra

**Prerequisite:** Math 205A with a grade of 'C' or better.

**Advisory:** Concurrent enrollment in Guidance 563B is advised.

**Transferable:** No; GAV-GE: B4

This course contains the material covered in the second half of the Elementary Algebra Course. It will cover factoring, polynomials, solving quadratic equations by factoring, rational expressions and equations, complex fractions, radicals and radical equations, solving quadratic equations by completing the square and the quadratic formula. Application problems are integrated throughout the topics.

4556	LEC	SS206	LOCKHART L LOCKHART L	4.00	2.5	MW F	0810A-0925A 0810A-0900A	
4557	LEC	LS101 PH103	LOCKHART L LOCKHART L	4.00	2.5	TuTh F	1110A-1225P 1110A-1200P	
6124	LEC	SS206	EHLERS G	4.00	2.5	TuTh	0630P-0820P	

## Be Aware

If your goal is a MULTIPLE SUBJECT CREDENTIAL,  
you may need MATH 12, Math for Elementary Teachers.

Sect. Type Room Instructor Hrs. Units Days Begin-End Footnotes

Sect. Type Room Instructor Hrs. Units Days Begin-End Footnotes

**MATH 233 Intermediate Algebra**

**Prerequisite:** Mathematics 205 or Mathematics 205A and 205B or Mathematics 206 with a grade of 'C' or better.

**Transferable:** No; GAV-GE: B4

Review of basic concepts, linear equations and inequalities, graphs and functions, systems of linear equations, polynomials and polynomial functions, factoring, rational expressions and equations, roots, radicals, and complex numbers, solving quadratic equations, exponential and logarithmic functions, and problem solving strategies.

4558	LEC	PH103	ARID A DRESCH M	5.00	5.0	DAILY	0835A-0925A	1
4559	LEC	MHG11	KERCHEVAL S	5.00	5.0	MTuWTh	0900A-1005A	1
<b>Above class meets at Morgan Hill Community site</b>								
4560	LEC	CH109	JUKL H	5.00	5.0	MTuWTh	0945A-1050A	1
4561	LEC	HOL2	FULLER G	5.00	5.0	MTuWTh	1030A-1135A	1
<b>Above class meets at the Hollister Briggs site</b>								
4562	LEC	CH109	DWYER M	5.00	5.0	MTuThF	1110A-1225P	1 36
<b>Section 4562 (above) is part of a learning community. Students must also sign up for MATH 299C, sect. 4564. See below.</b>								
4563	LEC	PH103	LEER	5.00	5.0	MTuWTh	1245P-0150P	
6125	LEC	HOL4	RAND K	5.00	5.0	TuTh	0600P-0835P	1
<b>Above class meets at the Hollister Briggs site</b>								
6126	LEC	CH109	STAFF	5.00	5.0	MW	0630P-0855P	1

**MATHEMATICS - Learning Community**

**Close Encounters with Math and Science**

- Have you ever thought about a career in science, engineering, or math, but doubted your ability to get through the math classes required?
- Are you looking for a supportive environment to help you with your math?
- Have you ever wondered how math applies to real world problems?
- Would you like to gain some hands-on experience with tools and techniques of science?

**Then this Learning Community is for you!**

In these linked classes you'll have opportunities to:

- improve math-specific study skills and get help from in-class tutors
- get information about the career paths in science
- find out more about the MESA program and other extracurricular activities that will ultimately help you transfer to a four-year institution
- use basic scientific equipment (such as the microscope) and learn scientific methodology
- participate in service learning activities, such as Science Alive
- hear guest speakers from various science/math careers
- go on a field trip to a research institution such as MBARI (Monterey Bay Aquarium Research Institute) or a four-year university.

To get more information about this exciting new program, contact math instructor Marlene Dwyer in Ph110, call (408) 848-4897, or email mdwyer@gavilan.edu

**Sign up for:**

**MATH 233 Intermediate Algebra**

**Corequisite:** Enrollment in appropriate section of MATH 299C which is part of a learning community.

**Prerequisite:** Mathematics 205 or Mathematics 205A and 205B or Mathematics 206 with a grade of 'C' or better.

**Transferable:** No; GAV-GE: B4

Review of basic concepts, linear equations and inequalities, graphs and functions, systems of linear equations, polynomials and polynomial functions, factoring, rational expressions and equations, roots, radicals, and complex numbers, solving quadratic equations, exponential and logarithmic functions, and problem solving strategies.

4562	LEC	CH109	DWYER M	5.00	5.0	MTuThF	1110A-1225P	1 36
------	-----	-------	---------	------	-----	--------	-------------	------



**MATH 299C Math for Science**

**Corequisite:** Enrollment in appropriate section of MATH 233 which is part of a learning community.

**Transferable:** No

This course will provide a combination of math study skills, introduction to scientific equipment and technology for mathematics, collection and analysis of data from various branches of science, one or more field trips, investigation of science careers and program choices at the transfer level.

4564	LEC	CH109	DWYER M	1.00	1.0	W	1110A-1200P	36
------	-----	-------	---------	------	-----	---	-------------	----

**Gavilan College Overview of Math Courses**

Grade of "C" or better required in order to progress to the next course

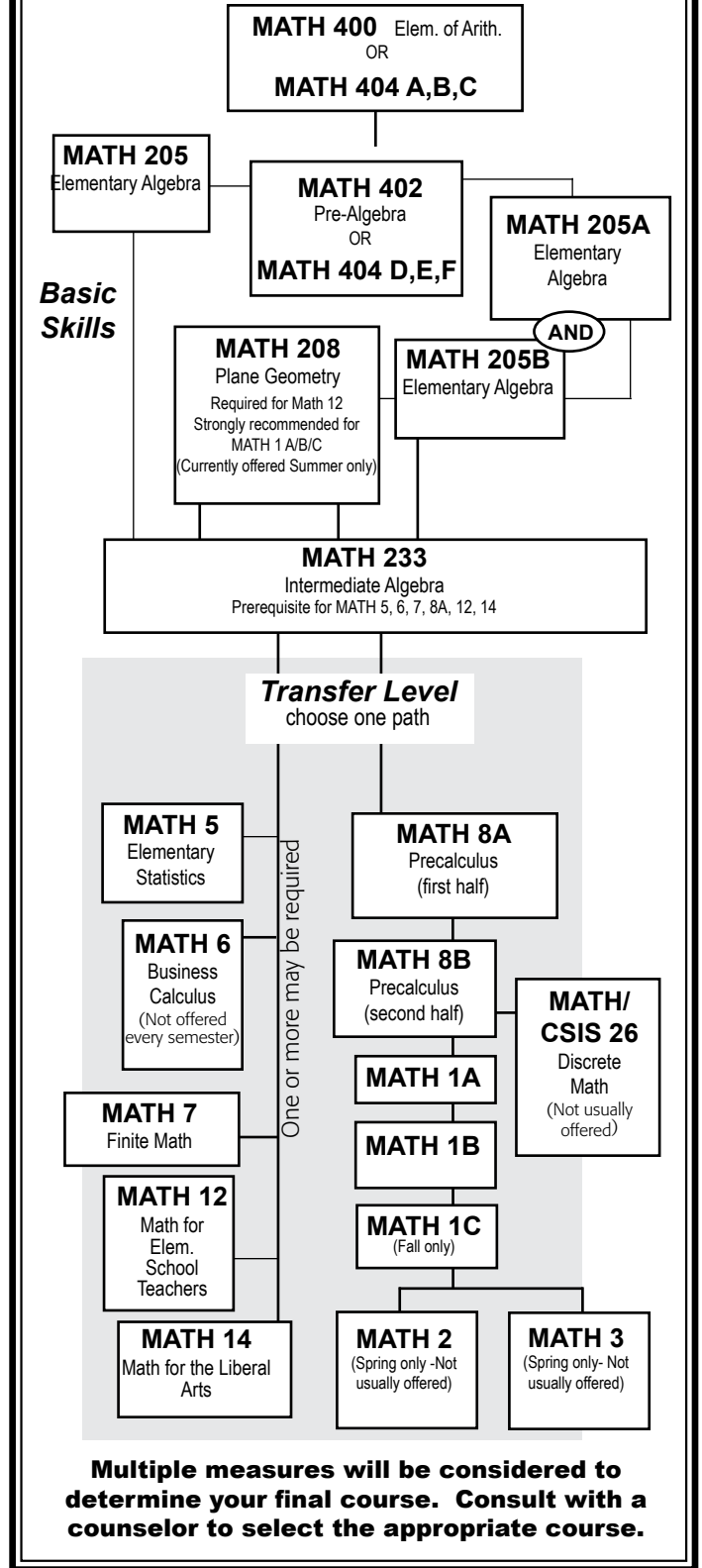



Sect.	Type	Room	Instructor	Hrs.	Units	Days	Begin-End	Footnotes
-------	------	------	------------	------	-------	------	-----------	-----------

**MATH 400 Elements of Arithmetic**

Transferable: No

Essential arithmetic operations, whole numbers, integers, fractions, decimals, ratio, proportion, percent, applications of arithmetic, and critical thinking, as well as math-specific study skills. Units earned in this course do not count toward the associate degree and/or other certain certificate requirements.

4565	L/L	PH102	DACHKOVA E DACHKOVA E	4.00	3.0	MW F	0810A-0925A 0835A-0925A	1
4566	L/L	LS102	EHLERS G EHLERS G	4.00	3.0	TuTh F	0945A-1100A 1010A-1100A	1
6127	L/L	SS206	FULLER G	4.00	3.0	MW	0600P-0750P	1

**MATH 402 Pre-Algebra**

Prerequisite: Completion of Math 400 with a 'C' or better, or assessment test recommendation.

Transferable: No

This course covers operations with integers, fractions and decimals and associated applications, percentages, ratio, and geometry and measurement, critical thinking and applications. Elementary algebra topics such as variables, expressions, and solving equations are introduced.

4567	L/L	LS102	JUKL H JUKL H	4.00	3.0	TuTh F	0810A-0925A 0835A-0925A	1
4568	L/L	PH102	LEE R LEE R	4.00	3.0	MW F	0945A-1100A 1010A-1100A	1
4569	L/L	CH102	DWYER M DWYER M	4.00	3.0	TuTh F	1245P-0200P 0110P-0200P	1
6128	L/L	LS101	STAFF	4.00	3.0	TuTh	0600P-0750P	1

**MATH 404A-G Self-Paced Basic Math**

These classes involve both lecture and hands-on computer components. All sections are open for late registration.

Transferable: No

This course is a remedial, modular, self-paced course. Application and critical thinking skills are developed in each module. Module A covers operations with whole numbers, equivalent fractions, multiplying and dividing fractions. Module B covers adding and subtracting fractions, and operations with decimals. Module C covers ratio and proportion, percent, and units of measurement. Module D reviews fractions, decimals, percentages, and covers operations with integers, and working with variables. Module E covers real numbers, fractions, exponents, scientific notation, and order of operations. Module F covers expressions, polynomials, and equations. Module G covers geometric figures, perimeter and area, surface area and volume, triangles and parallelograms, and similar figures. This course has the option of a letter grade or credit/no credit.

**MATH 404A Self-Paced Basic Math**

4570	L/L	PH101	DACHKOVA E DACHKOVA E	1.30	1.0	TuTh F	1245P-0230P 1210P-0100P	179
------	-----	-------	--------------------------	------	-----	-----------	----------------------------	-----

**MATH 404B Self-Paced Basic Math**

L/L	PH101	DACHKOVA E DACHKOVA E	1.30	1.0	TuTh F	1245P-0230P 1210A-1000A	179
-----	-------	--------------------------	------	-----	-----------	----------------------------	-----

**MATH 404C Self-Paced Basic Math**

4572	L/L	PH101	DACHKOVA E DACHKOVA E	1.30	1.0	TuTh F	1245P-0230P 1210P-0100P	179
------	-----	-------	--------------------------	------	-----	-----------	----------------------------	-----

**MATH 404D Self-Paced Basic Math**

4573	L/L	PH101	DACHKOVA E DACHKOVA E	1.30	1.0	TuTh F	1245P-0230P 1210P-0100P	179
------	-----	-------	--------------------------	------	-----	-----------	----------------------------	-----

**MATH 404E Self-Paced Basic Math**

4574	L/L	PH101	DACHKOVA E DACHKOVA E	1.30	1.0	TuTh F	1245P-0230P 1210A-1000A	179
------	-----	-------	--------------------------	------	-----	-----------	----------------------------	-----

**MATH 404F Self-Paced Basic Math**

4575	L/L	PH101	DACHKOVA E DACHKOVA E	1.30	1.0	TuTh F	1245P-0230P 1210P-0100P	179
------	-----	-------	--------------------------	------	-----	-----------	----------------------------	-----

**MATH 404G Self-Paced Basic Math**

4576	L/L	PH101	DACHKOVA E DACHKOVA E	1.30	1.0	TuTh F	1245P-0230P 1210P-0100P	179
------	-----	-------	--------------------------	------	-----	-----------	----------------------------	-----

Sect.	Type	Room	Instructor	Hrs.	Units	Days	Begin-End	Footnotes
-------	------	------	------------	------	-------	------	-----------	-----------

**Medical Terminology: See Business****MUSIC****MUS 1A Music History and Literature**

Advisory: Eligible for English 250 and English 260.

Transferable: CSU; UC; CSU-GE: C2; IGETC: 3A; GAV-GE: C2; CAN: MUS 8

A survey of the development of music in western civilization including representative composers from the Medieval to the present. Music 1A will study the music and styles from the Medieval to the Romantic period.

4577	ONLINE	BENKMAN N		3.00	3.0	DHR	0000-0000	38
------	--------	-----------	--	------	-----	-----	-----------	----



This online class will be delivered entirely over the internet. After enrolling, start the class by going to <http://www.gavilan.edu/disted/>, click on your class link, and email the instructor at [nbenkman@gavilan.edu](mailto:nbenkman@gavilan.edu). Students who have not begun the class or contacted the instructor by 5 pm on January 26 will be dropped from the class.

**MUS 1B Music History and Literature**

Advisory: Eligible for English 250 and English 260.

Transferable: CSU; UC; CSU-GE: C2; IGETC: C2; GAV-GE: C2

A survey of the development of music in western civilization including representative composers from the Medieval period to the present. Music 1B will study the music and styles from late Romanticism to the present.

4578	LEC	AL101	JUNCKER A	3.00	3.0	TuTh	0945A-1100A	
------	-----	-------	-----------	------	-----	------	-------------	--

**MUS 3A Harmony - Theory - Musicianship**

Advisory: Must be taken in sequence.

Transferable: CSU; UC; CSU-GE: C1; GAV-GE: C1

Fundamentals of music, beginning harmony.

4579	L/L	AL101	JUNCKER A	6.00	4.0	MW&2	0910A-1100A	
------	-----	-------	-----------	------	-----	------	-------------	--

**MUS 3B Harmony - Theory - Musicianship**

Advisory: Must be taken in sequence.

Transferable: CSU; UC; GAV-GE: C1

Fundamentals of music, beginning harmony.

4580	L/L	TH130	JUNCKER A	6.00	4.0	TuTh&2	1110A-0100P	
------	-----	-------	-----------	------	-----	--------	-------------	--

**MUS 3C Intermediate Harmony - Theory**

Advisory: Music 3B

Transferable: CSU; UC; GAV-GE: C1

Continuation of Music 3AB. Chromatic harmony, analysis and composition.

4581	L/L	TH130	JUNCKER A	6.00	4.0	TuTh&2	1110A-0100P	
------	-----	-------	-----------	------	-----	--------	-------------	--

**MUS 3D Intermediate Harmony - Theory**

Advisory: Music 3C

Transferable: CSU; UC; GAV-GE: C1

Continuation of Music 3C. Analysis and composition.

4582	L/L	TH130	JUNCKER A	6.00	4.0	TuTh&2	1110A-0100P	
------	-----	-------	-----------	------	-----	--------	-------------	--

**MUS 4A Beginning Piano**

Advisory: Must be taken in sequence.

Transferable: CSU; UC; CSU-GE: C1; GAV-GE: C1

Introduction to music fundamentals and keyboard technique. Development of beginning keyboard skills including note reading in bass and treble clef, fingering, rhythm, key signatures, primary chords and inversions.

4583	L/L	TH130	HICKS G	4.00	3.0	MW&1	0810A-0925A	
4584	L/L	TH130	LIN C	4.00	3.0	TuTh&1	0945A-1100A	
6129	L/L	TH130	MELLO S	4.00	3.0	M	0600P-0950P	

**MUS 4B Beginning Piano**

Advisory: Music 4A

Transferable: CSU; UC; GAV-GE: C1

Continuation of Music 4A.

4585	L/L	TH130	HICKS G	3.00	2.0	MW	0945A-1100A	
6130	L/L	TH130	MELLO S	3.00	2.0	M	0630P-0920P	

Sect. Type Room Instructor Hrs. Units Days Begin-End Footnotes

**MUS 5A Intermediate Piano****Advisory:** Music 4B**Transferable:** CSU; UC; GAV-GE: C1

Development of intermediate keyboard skills through means of scales, chords, and technical studies. Continuation of music fundamentals and beginning keyboard harmony; introduction of easier classical and standard piano literature.

4586	L/L	TH130	HICKS G	3.00	2.0	MW	0945A-1100A
6131	L/L	TH130	MELLO S	3.00	2.0	M	0645P-0935P

**MUS 5B Intermediate Piano****Advisory:** Music 5A**Transferable:** CSU; UC; GAV-GE: C1

Development of intermediate keyboard skills through means of scales, chords and technical studies. Continuation of music fundamentals and beginning keyboard harmony; introduction of easier classical and standard piano literature.

4587	L/L	TH130	HICKS G	3.00	2.0	MW	0945A-1100A
6132	L/L	TH130	MELLO S	3.00	2.0	M	0645P-0935P

**MUS 5C Advanced Piano****Advisory:** Music 5B**Transferable:** CSU; UC; GAV-GE: C1

Development of advanced keyboard skills through means of scales, chords and technical studies. Continuation of music fundamentals and keyboard harmony; introduction of moderately difficult classical and standard piano literature.

4588	L/L	TH130	HICKS G	3.00	2.0	MW	0945A-1100A
6133	L/L	TH130	MELLO S	3.00	2.0	M	0645P-0935P

**MUS 5D Advanced Piano****Advisory:** Music 5C**Transferable:** CSU; UC; GAV-GE: C1

Development of advanced keyboard skills through means of scales, chords and technical studies. Continuation of music fundamentals and keyboard harmony; introduction of moderately difficult classical and standard piano literature.

4589	L/L	TH130	HICKS G	3.00	2.0	MW	0945A-1100A
6134	L/L	TH130	MELLO S	3.00	2.0	M	0645P-0935P

**MUS 8A Beginning Voice****Advisory:** Continues in sequence or by demonstrated proficiency.**Transferable:** CSU; UC; GAV-GE: C1

Development of techniques in the art of singing and interpreting serious music in various styles. Study of the basic techniques of tone production, breathing and related skills. Basic repertoire development.

4590	L/L	AL101	PRUITT N	3.00	2.0	TuTh&1	1110A-1200P
------	-----	-------	----------	------	-----	--------	-------------

**MUS 8B Beginning Voice****Advisory:** Music 8A or demonstrated proficiency.**Transferable:** CSU; UC; GAV-GE: C1

Development of techniques in the art of singing and interpreting serious music in various styles. Study of the basic techniques of tone production, breathing and related skills. Basic repertoire development.

4591	L/L	AL101	PRUITT N	3.00	2.0	TuTh&1	1210P-0100P
------	-----	-------	----------	------	-----	--------	-------------

**MUS 8C Intermediate Voice****Advisory:** Music 8B or demonstrated proficiency.**Transferable:** CSU; UC; GAV-GE: C1

Development of techniques in the art of singing and interpreting serious music in various styles. Study of the basic techniques of tone production, breathing and related skills. Basic repertoire development.

4592	L/L	AL101	PRUITT N	3.00	2.0	TuTh&1	1210P-0100P
------	-----	-------	----------	------	-----	--------	-------------

**MUS 8D Intermediate Voice****Advisory:** Music 8C or demonstrated proficiency.**Transferable:** CSU; UC; GAV-GE: C1

Development of techniques in the art of singing and interpreting serious music in various styles. Study of the basic techniques of tone production, breathing and related skills. Basic repertoire development.

4593	L/L	AL101	PRUITT N	3.00	2.0	TuTh&1	1210P-0100P
------	-----	-------	----------	------	-----	--------	-------------

Sect. Type Room Instructor Hrs. Units Days Begin-End Footnotes

Winner of the Presidential Award for Excellence in Math and Science and the Innovations in American Government Award, a project of the Kennedy School of Government at Harvard University and the Ford Foundation

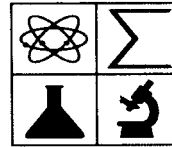

# MESA

MATHEMATICS • ENGINEERING • SCIENCE ACHIEVEMENT

- ◆ Are you a math based major? (BIO, CSIS, Architecture, etc.)
- ◆ Do you want to transfer to a 4-year university?
- ◆ Do you have financial need?
- ◆ Are you a first generation college student?

**You may be eligible!**

Gavilan's College's MESA Program is now accepting applications. MESA students are entitled to workshops, academic advising, university visits, tutoring and more!

For more information call 408-848-4887  
or visit the MESA Study Center in PH 105.

◆ www.gavilan.edu/mesa ◆

**FREE TUTORING**

*Gavilan College*

# Math Lab

**Services for Gavilan Students:**

- ◆ **Free Tutoring for MATH**
- ◆ **Free Computer Assistance**

Staffed by the Math Department

For daily schedule, or for free math downloads,  
check our web site - <http://gavilan.edu/mathlab/>

**PH 101**

**Close Encounters with Math and Science**

- Have you ever thought about a career in science, engineering, or math, but doubted your ability to get through the math classes required?
- Are you looking for a supportive environment to help you with your math?
- Have you ever wondered how math applies to real world problems?
- Would you like to gain some hands-on experience with tools and techniques of science?

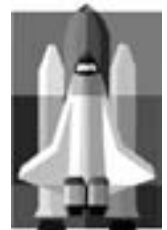

Then this Learning Community is for you! **Sign up for:**

**MATH 233 Intermediate Algebra** sect. 4562 MTuThF 1110A-1225P  
**MATH 299C Math for Science** sect. 4564 W 1110A-1200P

**See page 81 for class listings.**

For more information about this exciting new program contact math instructor Marlene Dwyer in Ph110, call (408) 848-4897, or email [mdwyer@gavilan.edu](mailto:mdwyer@gavilan.edu)

Sect.	Type	Room	Instructor	Hrs.	Units	Days	Begin-End	Footnotes
-------	------	------	------------	------	-------	------	-----------	-----------

**MUS 9A Guitar****Advisory:** Students must provide their own guitars.**Transferable:** CSU; UC; GAV-GE: C1

An introduction to playing the guitar. Basic staff notation, correct fingering and chord arpeggios are covered. Emphasis is also placed on developing musical listening skills. Students must provide their own guitars. May be repeated once for credit.

4756	LAB	HOL2	MONTOYA T	3.00	1.0	M	0100P-0350P	
------	-----	------	-----------	------	-----	---	-------------	--

**Above class meets at the Hollister Briggs site**

6135	LAB	TH127	MONTOYA T	3.00	1.0	M	0600P-0850P	
------	-----	-------	-----------	------	-----	---	-------------	--

**MUS 9B Guitar****Advisory:** Music 9A; students must provide their own guitars.**Transferable:** CSU; UC; GAV-GE: C1

An introduction to playing the guitar. Basic staff notation, correct fingering and chord arpeggios are covered. Emphasis is also placed on developing musical listening skills. Students must provide their own guitars. May be repeated once for credit.

6136	LAB	TH127	MONTOYA T	3.00	1.0	M	0700P-0950P	
------	-----	-------	-----------	------	-----	---	-------------	--

**MUS 12 Vocal Ensemble****Transferable:** CSU; UC; GAV-GE: C1

The day Vocal Ensemble will focus on individual and group performance of popular and alternative commercial music, and will rehearse and perform with a backup band. The evening Vocal Ensemble will study, rehearse and perform choral music in a broad spectrum of musical genre and styles. Included will be the study of vocal and rehearsal techniques as they relate to ensemble performance. Course may be repeated three times for credit.

4594	LAB	AL101	JUNCKER A	4.00	2.0	MW	1245P-0235P	
------	-----	-------	-----------	------	-----	----	-------------	--

6137	LAB	GHS	ROBB P	4.00	2.0	Tu&1	0730P-0945P	67
------	-----	-----	--------	------	-----	------	-------------	----

**See Footnote: Above class meets Off Campus****MUS 13 Concert Choir****Advisory:** Previous choral experience is preferred but not required. The student should have the ability to match a given pitch.**Transferable:** CSU; UC; GAV-GE: C1

The Concert Choir will study, rehearse and perform choral music from the 15th century to the present in a variety of musical styles with emphasis on the larger choral works and their preparation for public concert. Course may be repeated three times for credit.

6138	L/L	GHS	ROBB P	4.00	2.0	Tu&1	0730P-0945P	67
------	-----	-----	--------	------	-----	------	-------------	----

**See Footnote: Above class meets Off Campus****MUS 14A Instrumental Ensemble****Transferable:** CSU; GAV-GE: C1

Instruction for the experienced musician with emphasis on the study and performance of a wide variety of musical styles from Renaissance to 20th century music for traditional ensembles, and extensive consideration of contemporary commercial and alternative repertoire, and performance techniques for popular ensembles.

4595	LAB	AL101	MARQUESA	4.00	2.0	MW	1245P-0235P	
------	-----	-------	----------	------	-----	----	-------------	--

6139	LAB	AL101	MOLLICONE H	4.00	2.0	W&1	0700P-0950P	
------	-----	-------	-------------	------	-----	-----	-------------	--

**MUS 14B Instrumental Ensemble****Transferable:** CSU; GAV-GE: C1

Instruction for the experienced musician with emphasis on the study and performance of a wide variety of musical styles from Renaissance to 20th century music for traditional ensembles, and extensive consideration of contemporary commercial and alternative repertoire, and performance techniques for popular ensembles.

6140	LAB	AL101	MOLLICONE H	4.00	2.0	W&1	0700P-0950P	
------	-----	-------	-------------	------	-----	-----	-------------	--

Sect.	Type	Room	Instructor	Hrs.	Units	Days	Begin-End	Footnotes
-------	------	------	------------	------	-------	------	-----------	-----------

**MUS 14C Instrumental Ensemble****Transferable:** CSU; GAV-GE: C1

Instruction for the experienced musician with emphasis on the study and performance of a wide variety of musical styles from Renaissance to 20th century music for traditional ensembles, and extensive consideration of contemporary commercial and alternative repertoire, and performance techniques for popular ensembles.

6141	LAB	AL101	MOLLICONE H	4.00	2.0	W&1	0700P-0950P	
------	-----	-------	-------------	------	-----	-----	-------------	--

**MUS 14D Instrumental Ensemble****Transferable:** CSU; GAV-GE: C1

Instruction for the experienced musician with emphasis on the study and performance of a wide variety of musical styles from Renaissance to 20th century music for traditional ensembles, and extensive consideration of contemporary commercial and alternative repertoire, and performance techniques for popular ensembles.

6142	LAB	AL101	MOLLICONE H	4.00	2.0	W&1	0700P-0950P	
------	-----	-------	-------------	------	-----	-----	-------------	--

**MUS 21 Electronic Music/Sound Design****Advisory:** Eligible for English 250, 260 and Mathematics 205.**Transferable:** CSU; GAV-GE: C1

Fundamentals of electronic music synthesis using computers. Midi sequencing, digital sound processing, sampling, digital multi-track recording utilizing the college's state of the art midi studio. May be repeated three times for credit.

4596	L/L	LI128	STAFF	5.00	3.0	TuTh&2	1110A-1225P	
------	-----	-------	-------	------	-----	--------	-------------	--

**MUS 22 Field Work and Service****Required:** Learning contracts must be filled out and signed by the student and the supervising instructor.**Transferable:** CSU

Supervised field work within the college and with local agencies. Students serve in useful group activities in leadership roles prescribed for them by faculty or community agencies. A maximum of six units may be completed. This is a credit/no credit course.

4597	FEX	GHS	ROBB P	3.00	1.0	DHR	0000-0000	21 67
------	-----	-----	--------	------	-----	-----	-----------	-------

**See Footnote: Above class meets Off Campus**

4598	FEX	AL101	MOLLICONE H	3.00	1.0	DHR	0000-0000	21
------	-----	-------	-------------	------	-----	-----	-----------	----

**MUS 23 Independent Study****Required:** The study outline prepared by the student and the instructor must be filed with the department and the dean.**Transferable:** CSU

Designed to afford selected students specialized opportunities for exploring areas at the independent study level. The courses may involve extensive library work, research in the community, or special projects. May be repeated until six units of credit are accrued. This course has the option of a letter grade or credit/no credit.

4599	IND	GHS	ROBB P	3.00	1.0	DHR	0000-0000	22 67
------	-----	-----	--------	------	-----	-----	-----------	-------

**See Footnote: Above class meets Off Campus**

4600	IND	AL101	MOLLICONE H	3.00	1.0	DHR	0000-0000	22
------	-----	-------	-------------	------	-----	-----	-----------	----

4601	IND	TH130	JUNCKER A	3.00	1.0	DHR	0000-0000	22
------	-----	-------	-----------	------	-----	-----	-----------	----

4602	IND	AL102	JUNCKER A	6.00	2.0	DHR	0000-0000	22
------	-----	-------	-----------	------	-----	-----	-----------	----

4603	IND	AL101	PRUITT N	3.00	1.0	DHR	0000-0000	22
------	-----	-------	----------	------	-----	-----	-----------	----

4604	IND	AL101	PRUITT N	6.00	2.0	DHR	0000-0000	22
------	-----	-------	----------	------	-----	-----	-----------	----

4605	IND	TH130	HICKS G	3.00	1.0	DHR	0000-0000	22
------	-----	-------	---------	------	-----	-----	-----------	----

6143	IND	TH130	MELLO S	3.00	1.0	DHR	0000-0000	22
------	-----	-------	---------	------	-----	-----	-----------	----

6144	IND	TH127	MONTOYA T	3.00	1.0	M	0600P-0850P	22
------	-----	-------	-----------	------	-----	---	-------------	----

**MUS 26 Symphony****Advisory:** Demonstrated proficiency on individual's instrument and ability to read music.**Transferable:** CSU; UC; GAV-GE: C1

Study and performance of orchestral literature. Individual and sectional skills development. Perform in public concerts each semester. May be repeated until a maximum of 8 units are accrued.

6145	L/L	GY999	MOLLICONE H	4.00	2.0	W&1	0700P-0950P	
------	-----	-------	-------------	------	-----	-----	-------------	--

**MUS 28 Jazz/Pop Piano****Advisory:** Music 4A or the equivalent.**Transferable:** CSU; UC; GAV-GE: C1

Introduction to jazz and popular piano: Chord symbols, chord voicings, improvisation, arrangements in blues, jazz, and other popular music styles. May be repeated three times for credit.

6502	L/L	TH130	HICKS G	4.00	2.0	W&1	0600P-0850P	
------	-----	-------	---------	------	-----	-----	-------------	--

**Don't forget**

A counselor's signature is required if you take 17 or more units (spring or fall) or 5 or more units (summer). You do not need a counselor's signature to register for a class with a prerequisite that was successfully completed at Gavilan.

Sect. Type Room Instructor Hrs. Units Days Begin-End Footnotes

**MUS 98 Special Topics**

**Transferable:** CSU; GAV-GE: C1

Special topics courses examine current problems or issues of interest to students within a specific discipline area. For topical content information, consult with appropriate department chairperson. For transfer status, check with a counselor. This course may have the option of a letter grade or credit/no credit.

6146	LEC	GHS	ROBB P	3.00	1.0	Tu	0730P-0945P	67
<b>See Footnote: Above class meets Off Campus</b>								
6147	LEC	AL101	MOLLICONE H	3.00	1.0	W	0700P-0950P	

**Nursing: See Allied Health**

**Nutrition: See Biological Sciences**

**Performing Arts: See Theatre Arts (THEA)**

**PHILOSOPHY**

**PHIL 1 Introduction to Philosophy**

**Advisory:** Eligible for English 1A.

**Transferable:** CSU; UC; CSU-GE: C2; IGETC: 3B; GAV-GE: C2; CAN: PHIL 2

Philosophy 1 is intended as a survey of the major areas and traditions of philosophy. The course examines central and significant questions about the meaning of life, who determines what is morally right or wrong, the ideal society, the various notions social justice, what is reality, and many other ideas. In pursuing these questions, students will be asked to read texts from writers around the world, both contemporary and ancient, discuss current events, and apply 'theory' to movies such as "The Matrix" trilogy, novels, and any other relevant application of the student's own choice.

4672	LEC	SS206	HODGEE	3.00	3.0	TuTh	0810A-0925A	
------	-----	-------	--------	------	-----	------	-------------	--

**PHIL 2 Logic**

**Advisory:** Eligible for English 1A.

**Transferable:** CSU; UC; CSU-GE: A3; GAV-GE: C2; CAN: PHIL 6

Philosophy 2 is intended as a survey of the primary approaches to argumentation and what has been traditionally called 'correct' reasoning. Students will learn techniques of both deductive and inductive argumentation, basic symbolic logic, how to spot a fallacy, as well as how to apply these techniques to other aspects of their lives outside of the classroom. While logic is often quite formal, the goal is to see the practical application of this discipline. Students will become acquainted with the cultural variations to reasoning in addition to the standard Western focal approach.

4673	LEC	SS110	HODGEE	3.00	3.0	MW	0945A-1100A	
6154	LEC	HU102	JOHNSTON M	3.00	3.0	Tu	0630P-0920P	

**PHIL 3B Contemporary Moral Issues**

**Advisory:** Eligible for English 1A.

**Transferable:** CSU; UC; CSU-GE: C2; IGETC: 3B; GAV-GE: C2, E2

Contemporary Moral Issues in an applied ethics class that covers major ethical theories and contemporary moral issues in a pluralistic manner. This course will cover such issues as abortion and euthanasia, cloning, experimentation on human subjects, capital punishment, race/ethnicity, sexual orientation and sexual morality, world hunger and poverty, colonialism and post-colonialism, and so forth.

4674	LEC	HU105	HODGEE	3.00	3.0	TuTh	0945A-1100A	11
------	-----	-------	--------	------	-----	------	-------------	----

**PHIL 4 Critical Thinking and Writing**

**Prerequisite:** English 1A

**Transferable:** CSU; UC; CSU-GE: A3; IGETC: 1B; GAV-GE: C2

This course is designed to introduce the relationship between critical thinking and critical writing in a way that will be both enjoyable to the student and helpful in other aspects of life. The student will learn techniques of critical thinking, playing close attention to the current events, movies and popular media, music lyrics, as well as the textbook. Students will learn to identify deductive and inductive arguments and be able to evaluate their strength, create a strong argument of their own on a given topic, as well become experts in the area of critical analysis. The goal is to enable students to become strong, well informed, articulate members of the community as well as individuals with an empowered sense of self as an agent of change.

4675	LEC	SS205	HODGEE	3.00	3.0	MW	0810A-0925A	
4676	LEC	TH127	JOHNSTON M	3.00	3.0	TuTh	0400P-0515P	

Sect. Type Room Instructor Hrs. Units Days Begin-End Footnotes

**MUS 14A INSTRUMENTAL ENSEMBLE**

**MUS 12 VOCAL ENSEMBLE**

Play Rock & Roll  
Jazz  
Blues  
Top Hits  
Classics  
Your original songs!

The most fun you'll ever have in a class!

Sects. 4594/4595 with Art Juncker & Albert Marques MW 12:45 - 2:35 pm

**Campus EVENTS**

Theatre, sports, art, lectures, fiestas and more!

Log on to the Gavilan website: <http://www.gavilan.edu/pio> and click on Calendar of Events for a complete list of upcoming campus events!

**BACH TO BLUES**

**February 24, 2006**

Gavilan College Theater

Performers include:  
John Garcia, South Valley Symphony String Quartet, Maria Amir Khanian, Albert Marques, Art Juncker with the Gavilan College Ensemble, Sandra Marlowe, Nate Pruitt

Theatre Arts Box Office: 408-846-4973

Presented by Gavilan College in association with South Valley Symphony



Sect.	Type	Room	Instructor	Hrs.	Units	Days	Begin-End	Footnotes
<b>PHIL 6</b>	<b>Religions of the World</b>							
<b>Advisory:</b> Eligible for English 1A.								
<b>Transferable:</b> CSU; UC; CSU-GE: C2; IGETC: 3B; GAV-GE: C2, F								
Religion is a topic that ignites controversy -- most societies engage in religious practices, believe strongly in that tradition, and find a sense of identity within it. The controversy arises when differences are misunderstood, misrepresented, or placed in a hierarchy of assumed supremacy of one religion as superior to others. In this class, students explore the underlying commonality of various religious traditions, explore the uniqueness of the religions with which they are unfamiliar, and learn to see that diversity among beliefs doesn't have to create hostility. Students will explore religions from Indigenous Peoples throughout the world, East Asia (e.g. India), China, the Middle East, as well as some more recent trends in religion.								
4677	LEC	SS205	HODGEE	3.00	3.0	MW	1245P-0200P	

### Photography: See Art

## PHYSICAL EDUCATION: ACADEMIC

### PE 5 Individual and Dual Sports

**Advisory:** Eligible for English 250 and English 260.

**Transferable:** CSU, UC; GAV-GE: E1

Designed for those planning to work with children in the field of physical education or recreation. Activities such as badminton, bowling, golf, tennis, and archery may be covered. This course has the option of a letter grade or credit/no credit.

4612	L/L	GY131G	LANGO J	5.00	3.0	TuTh&2	1110A-1225P	
------	-----	--------	---------	------	-----	--------	-------------	--



### PE 13A Fundamentals of Volleyball

**Transferable:** CSU

This course offers basic instruction in the theory, strategies, and techniques of volleyball for the purpose of preparing the student in the fundamental aspects of playing and coaching the game. May be repeated once for credit. This course has the option of a letter grade or credit/no credit.

4615	L/L	GY131G	PASCUCCIS	4.00	2.0	MW	1245P-0230P	
------	-----	--------	-----------	------	-----	----	-------------	--

## PHYSICAL EDUCATION: ACTIVITIES

### PE 16 Swimming

**Transferable:** CSU; UC; CSU-GE: E1; GAV-GE: E1

Coeducational activity designed for all skill levels. The course teaches the techniques of a variety of strokes and includes conditioning activities. Instruction is tailored to meet individual and group needs. May be repeated three times for credit. This course has the option of a letter grade or credit/no credit.

4616	LAB	GY100P	DODD S	3.00	1.0	MW	1230P-0145P	
4617	LAB	GY100P	DODD S	3.00	.5	MW	1230P-0145P	11
03/20/06 - 05/24/06								

### PE 17 Golf

**Transferable:** CSU; UC; CSU-GE: E1; GAV-GE: E1

Coeducational activity designed for all skill levels; fundamentals, techniques, rules and etiquette of golf. May be repeated three times for credit. This course has the option of a letter grade or credit/no credit.

4618	LAB	GY200C	NEMETH S	3.00	1.0	MW	0945A-1100A	49
4619	LAB	GY200C	NEMETH S	3.00	.5	MW	0945A-1100A	11 49
03/20/06 - 05/24/06								
6148	LAB	GY200C	KRAUSE S	3.00	.5	S	0900A-1130A	11 49 55
03/18/06 - 05/20/06								

### PE 20 Bowling

**Transferable:** CSU; UC; CSU-GE: E1; GAV-GE: E1

Coeducational activity designed for beginning and intermediate bowlers; fundamentals and techniques of bowling. Scoring, bowling etiquette, terminology and team bowling are included. May be repeated three times for credit. This course has the option of a letter grade or credit/no credit.

4620	LAB	GIBOWL	LANGO J	3.00	1.0	TuTh	0810A-0925A	62
------	-----	--------	---------	------	-----	------	-------------	----

See Footnote: Above class meets Off Campus

### PE 21 Volleyball

**Transferable:** CSU; UC; CSU-GE: E1; GAV-GE: E1

Coeducational activity designed for beginning and intermediate volleyball students; rules, strategy and fundamentals of volleyball. May be repeated three times for credit. This course has the option of a letter grade or credit/no credit.

4621	LAB	GY131G	PASCUCCIS	3.00	1.0	MW	1245P-0200P	
------	-----	--------	-----------	------	-----	----	-------------	--

### PE 23 Independent Study

**Required:** The study outline prepared by the student and the instructor must be filed with the department and the dean.

**Transferable:** CSU

Designed to afford selected students specialized opportunities for exploring areas at the independent study level. The courses may involve extensive library work, research in the community, or special projects. May be repeated until six units of credit are accrued. This course has the option of a letter grade or credit/no credit.

4622	IND	GY116	DODD S	6.00	2.0	DHR	0000-0000	22
------	-----	-------	--------	------	-----	-----	-----------	----

### PE 24 Individualized Weight Training

**Transferable:** CSU; UC; CSU-GE: E1; GAV-GE: E1

An open laboratory for those who desire an individualized strength program using exercise machines and free weights. May be repeated three times for credit. This course has the option of a letter grade or credit/no credit.

4623	LAB	GY123	DODD S	3.00	1.0	DHR	0000-0000	87
------	-----	-------	--------	------	-----	-----	-----------	----

For lab hours see ad on page 87.

4624	LAB	GY123	DODD S	1.50	.5	DHR	0000-0000	87
------	-----	-------	--------	------	----	-----	-----------	----

For lab hours see ad on page 87.

### PE 25 Soccer

**Transferable:** CSU; UC; CSU-GE: E1; GAV-GE: E1

Co-educational activity designed for those who desire an individualized strength program using exercise machines and free weights. May be repeated three times for credit. This course has the option of a letter grade or credit/no credit.

4625	LAB	GY131G	BEHLER M	3.00	1.0	MW	0810A-0925A	
------	-----	--------	----------	------	-----	----	-------------	--

### PE 27 Basketball

**Transferable:** CSU; UC; CSU-GE: E1; GAV-GE: E1

Co-educational activity designed for all skill levels. Fundamentals, strategy and rules of the game are included. May be repeated three times for credit. This course has the option of a letter grade or credit/no credit.

4626	LAB	GY131G	SHOEMAKER C	3.00	.5	TuTh	0210P-0400P	11
------	-----	--------	-------------	------	----	------	-------------	----

03/21/06 - 05/25/06

### PE 33 Walk/Run for Fitness

**Transferable:** CSU; UC; CSU-GE: E1; GAV-GE: E1

A program of walking and/or running designed to improve cardiovascular fitness and strengthen the muscles throughout the body. This course has the option of a letter grade or credit/no credit and may be repeated three times for credit.

4627	LAB	GY131G	DODD S	3.00	1.0	MW	0810A-0925A	
------	-----	--------	--------	------	-----	----	-------------	--

### PE 39 Fencing

**Transferable:** CSU; UC; CSU-GE: E1; GAV-GE: E1

This course will explore the offensive and defensive fencing skills with a foil. May be repeated three times for credit. This course has the option of a letter grade or credit/no credit.

6149	LAB	GY131G	DECESARE J	3.00	1.0	M	0630P-0920P	44
------	-----	--------	------------	------	-----	---	-------------	----

### PE 44 Aerobics

**Transferable:** CSU; UC; CSU-GE: E1; GAV-GE: E1

A program of aerobic fitness. Includes various forms of exercise to improve health, heart, and body composition. May be repeated three times for credit. This course has the option of a letter grade or credit/no credit.

4643	LAB	GY131G	BEHLER M	3.00	1.0	MW	1110A-1225P	
------	-----	--------	----------	------	-----	----	-------------	--

## PE Activities

Classes can be taken for letter grade or CR/NC.

Sect. Type Room Instructor Hrs. Units Days Begin-End Footnotes

**PE 46 Agility and Motor Development**

**Transferable:** CSU; UC; CSU-GE: E1; GAV-GE: E1

An activity class designed to improve and increase agility and motor development through various exercise and exercise programs. May be repeated three times for credit. This course has the option of a letter grade or credit/no credit.

4644	LAB	GY131G	LANGO J	3.00	1.0	MTuWTh	0310P-0350P	
4645	LAB	GY131G	LANGO J	3.00	.5	MTuWTh	0310P-0350P	11

03/27/06 - 05/25/06

**PE 61 Swim for Fitness**

**Transferable:** CSU; UC; CSU-GE: E1; GAV-GE: E1

Designed to develop endurance and swimming skills in order to maintain good cardiovascular/physical fitness. Intermediate swimming ability recommended. May be repeated three times for credit. This course has the option of a letter grade or credit/no credit.

6150	LAB	GY100P	DODD S	3.00	.5	TuTh	0500P-0615P	11
------	-----	--------	--------	------	----	------	-------------	----

03/21/06 - 05/25/06

**PE 62 Yoga**

**Transferable:** CSU; UC; CSU-GE: E1; GAV-GE: E1

Co-educational activity designed for beginning yoga students. A program designed to improve flexibility and reduce stress, by learning a series of postures and focusing on proper breathing techniques. May be repeated three times for credit. This course has the option of a letter grade or credit/no credit.

4646	LAB	APE101	MUSCARI D	3.00	1.0	MW	0110P-0225P	
6151	LAB	MHG10	MUSCARI D	3.00	1.0	MW	0500P-0615P	

**Above class meets at Morgan Hill Community site**

6153	LAB	VET218	MUSCARI D	3.00	1.0	TuTh	0500P-0615P	41
------	-----	--------	-----------	------	-----	------	-------------	----

**See Footnote: Above class meets Off Campus**

**PE 64 Individualized Cardiovascular Fitness**

**Transferable:** CSU; UC; CSU-GE: E1; GAV-GE: E1

A fitness program which develops cardiovascular endurance through an individualized open lab format. May be repeated three times for credit. This course has the option of a letter grade or credit/no credit.

4647	LAB	GY123	DODD S	3.00	1.0	DHR	0000-0000	87
------	-----	-------	--------	------	-----	-----	-----------	----

**For lab hours see ad (right column).**

4648	LAB	GY123	DODD S	1.50	.5	DHR	0000-0000	87
------	-----	-------	--------	------	----	-----	-----------	----

**For lab hours see ad (right column).**

**PE 70 Pilates**

**Transferable:** CSU; UC; CSU-GE: E1; GAV-GE: E1

This class utilizes the Pilates exercise system focused on improving flexibility and strength for the total body through a series of controlled movements. May be repeated three times for credit. This course has the option of a letter grade or credit/no credit.

4650	LAB	APE101	MUSCARI D	3.00	1.0	TuTh	0110P-0225P	
------	-----	--------	-----------	------	-----	------	-------------	--

**PHYSICAL EDUCATION: ADAPTED**

**PE 34 Adapted Aquatic Exercise**

**Transferable:** CSU; UC; CSU-GE: E1; GAV-GE: E1

Designed to help individuals who by the nature of their disability such as wheelchair use, back injury, cardiovascular impairment, multiple sclerosis or other disabling condition require a specific aquatic exercise program that will contribute to their physical well-being. May be repeated as necessary based on measurable progress as documented in the student's educational contract. This course has the option of a letter grade or credit/no credit.

4628	LAB	GY100P	ELLIS D	3.00	1.0	MW	0810A-0925A	9075
4629	LAB	GY100P	ELLIS D	3.00	1.0	MW	1110A-1225P	9075
4630	LAB	GY100P	ELLIS D CRETINA A	3.00	1.0	TuTh	1110A-1225P	9075

Students should be aware that there are inherent risks involved in any physical exercise. Students are strongly advised to consult a physician prior to participating in any physical education activity.

Sect. Type Room Instructor Hrs. Units Days Begin-End Footnotes

What's Her-Story?



What's His-Story?

It's all our story.

Come investigate and help us write the many stories that make our history.

History Department classes - page 76

**PE 24 Individualized Weight Training**

**PE 64 Cardiovascular Fitness**

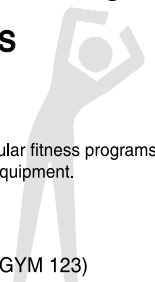

**Open Lab Class Format**

Designed for individualized strength or cardiovascular fitness programs in an open lab setting using a variety of exercise equipment.

**Section hours by arrangement**

1.5 to 3 weekly hours ♦ .5 or 1.0 unit ♦ Fitness Center (GYM 123)

**Students should check in the first week of the semester during lab hours.**

**Spring Semester Fitness Center Lab Hours**

<b>Day</b>	MWF	7:00 am - 2:00 pm
	TTh	9:30 am - 1:30 pm
<b>Eve.</b>	MTWTh	4:30 pm - 6:30 pm



Application online [www.gavilan.edu](http://www.gavilan.edu)

Sect.	Type	Room	Instructor	Hrs.	Units	Days	Begin-End	Footnotes
-------	------	------	------------	------	-------	------	-----------	-----------

### PE 35 Adapted Swimming for Total Fitness

**Transferable:** CSU; UC; CSU-GE: E1; GAV-GE: E1

An individualized program of activities designed for students with physical disabilities to improve flexibility and range-of-motion, increase joint movement, improve circulation, and improve control of body movement through water adjustment and activities. Develops an appreciation of physical activity as a regular planned contribution to one's overall well-being. May be repeated as necessary based on measurable progress as documented in the student's educational contract. This course has the option of a letter grade or credit/no credit.

4631	LAB	GY100P	ELLIS D	3.00	1.0	MW	0810A-0925A	90 75
4632	LAB	GY100P	ELLIS D	3.00	1.0	MW	1110A-1225P	90 75
4633	LAB	GY100P	ELLIS D CRETIN A	3.00	1.0	TuTh	1110A-1225P	90 75

### PE 36 Adapted Physical Education

**Transferable:** CSU; UC; CSU-GE: E1; GAV-GE: E1

An individualized program of adaptive physical education activities designed to meet the needs of students with physical disabilities. Develops an appreciation of physical activity as a regular planned contribution to one's overall well-being. May be repeated as necessary based on measurable progress as documented in the student's educational contract. This course has the option of a letter grade or credit/no credit.

4634	LAB	APE108 APE120 APE121	ELLIS D ELLIS D ELLIS D	3.00	1.0	MW	0945A-1100A	90 75
4635	LAB	APE108 APE120 APE121 APE108	ELLIS D ELLIS D ELLIS D CRETIN A	3.00	1.0	TuTh	0945A-1100A	90 75
4636	LAB	APE108 APE120 APE121 APE108	ELLIS D ELLIS D ELLIS D CRETIN A	3.00	1.0	MW	1245P-0200P	90 75
4637	LAB	APE108 APE120 APE121	ELLIS D ELLIS D ELLIS D	3.00	1.0	TuTh	1245P-0200P	90 75

### PE 38 Adapted Cardiovascular Conditioning & Training

**Transferable:** CSU; UC; CSU-GE: E1; GAV-GE: E1

Prescribed exercises in weight training, stretching and cardiovascular conditioning for those individuals that have been disabled through stroke, cardiovascular accident, arthritis, multiple sclerosis, or other condition. May be repeated as necessary based on measurable progress as documented in the student's educational contract. This course has the option of a letter grade or credit/no credit.

4639	LAB	APE108 APE120 APE121	ELLIS D ELLIS D ELLIS D	3.00	1.0	MW	0945A-1100A	90 75
4640	LAB	APE108 APE120 APE121 APE108	ELLIS D ELLIS D ELLIS D CRETIN A	3.00	1.0	TuTh	0945A-1100A	90 75
4641	LAB	APE108 APE120 APE121 APE108	ELLIS D ELLIS D ELLIS D CRETIN A	3.00	1.0	MW	1245P-0200P	90 75
4642	LAB	APE108 APE120 APE121	ELLIS D ELLIS D ELLIS D	3.00	1.0	TuTh	1245P-0200P	90 75

### PE 534 Adapted Aquatic Exercise

**Transferable:** No

Designed to help individuals who by the nature of their disability such as wheelchair use, back injury, cardiovascular impairment, multiple sclerosis or other disabling condition require a specific aquatic exercise program that will contribute to their physical well being. May be repeated as necessary based on measurable progress as documented in the student's educational contract. This is a credit/no credit course.

4651	LAB	GY100P	ELLIS D	3.00	1.0	MW	0810A-0925A	90 75
4652	LAB	GY100P	ELLIS D	3.00	1.0	MW	1110A-1225P	90 75
4653	LAB	GY100P	ELLIS D CRETIN A	3.00	1.0	TuTh	1110A-1225P	90 75

Sect.	Type	Room	Instructor	Hrs.	Units	Days	Begin-End	Footnotes
-------	------	------	------------	------	-------	------	-----------	-----------

### PE 535 Adapted Swimming for Total Fitness

**Transferable:** No

An individualized program of activities designed for students with physical disabilities to improve flexibility and range-of-motion, increase joint movement, improve circulation, and improve control of body movement through water adjustment and activities. Develops an appreciation of physical activity as a regular planned contribution to one's overall well-being. May be repeated as necessary based on measurable progress as documented in the student's educational contract. This course is credit/no credit.

4654	LAB	GY100P	ELLIS D	3.00	1.0	MW	0810A-0925A	90 75
4655	LAB	GY100P	ELLIS D	3.00	1.0	MW	1110A-1225P	90 75
4656	LAB	GY100P	ELLIS D CRETIN A	3.00	1.0	TuTh	1110A-1225P	90 75

### PE 536 Adapted Physical Education

**Transferable:** No

An individualized program of adaptive physical education activities designed to meet the needs of students with physical disabilities. Develops an appreciation of physical activity as a regular planned contribution to one's overall well-being. May be repeated as necessary based on measurable progress as documented in the student's educational contract. This is a credit/no credit course.

4657	LAB	LOADCS CRETIN A		3.00	1.0	MW	0930A-1045A	70 90 75
<b>See Footnote: Above class meets Off Campus</b>								
4658	LAB	APE108 APE120 APE121	ELLIS D ELLIS D ELLIS D	3.00	1.0	MW	0945A-1100A	90 75
4659	LAB	APE108 APE120 APE121 APE108	ELLIS D ELLIS D ELLIS D CRETIN A	3.00	1.0	TuTh	0945A-1100A	90 75
4660	LAB	HOLLCC CRETIN A		3.00	1.0	MW	1115A-1230P	68 90 75
<b>See Footnote: Above class meets Off Campus</b>								
4661	LAB	APE108 APE120 APE121 APE108	ELLIS D ELLIS D ELLIS D CRETIN A	3.00	1.0	MW	1245P-0200P	90 75
4662	LAB	APE108 APE120 APE121	ELLIS D ELLIS D ELLIS D	3.00	1.0	TuTh	1245P-0200P	90 75

### PE 538 Adapted Cardiovascular Conditioning & Training

**Transferable:** No

Prescribed exercises in weight training, stretching and cardiovascular conditioning for those individuals that have been disabled through stroke, cardiovascular accident, arthritis, multiple sclerosis, or other condition. May be repeated as necessary based on measurable progress as documented in the student's educational contract. This is a credit/no credit course.

4663	LAB	APE108 APE120 APE121	ELLIS D ELLIS D ELLIS D	3.00	1.0	MW	0945A-1100A	90 75
4664	LAB	APE108 APE120 APE121 APE108	ELLIS D ELLIS D ELLIS D CRETIN A	3.00	1.0	TuTh	0945A-1100A	90 75
4665	LAB	APE108 APE120 APE121 APE108	ELLIS D ELLIS D ELLIS D CRETIN A	3.00	1.0	MW	1245P-0200P	90 75
4666	LAB	APE108 APE120 APE121	ELLIS D ELLIS D ELLIS D	3.00	1.0	TuTh	1245P-0200P	90 75
4667	LAB	LOADCS MARINGER J		3.00	1.0	TuTh	0110P-0215P	70 75
<b>See Footnote: Above class meets Off Campus</b>								

## Your educational plan:

You are expected to take the responsibility for scheduling an appointment with a counselor, preferably at least once a semester. The purpose of this appointment is to develop, review and update your educational plan to ensure that you are taking the appropriate courses to meet your educational goal.

Sect. Type Room Instructor Hrs. Units Days Begin-End Footnotes

Sect. Type Room Instructor Hrs. Units Days Begin-End Footnotes

**INTERCOLLEGIATE ATHLETICS****ATH 35 Basketball****Transferable:** CSU; UC; CSU-GE: E1; GAV-GE: E1

This course provides practice and competition in intercollegiate basketball. May be repeated three times for credit. This course has the option of a letter grade or credit/no credit.

4126 LAB GY131G SHOEMAKER C 10.00 1.0 DAILY 0200P-0400P 11  
01/23/06 - 03/03/064127 LAB GY131G NEMETH S 10.00 1.0 DAILY 0400P-0600P 11  
01/23/06 - 03/03/06**ATH 36 Golf****Transferable:** CSU; UC; CSU-GE: E1; GAV-GE: E1

This course provides practice and competition in intercollegiate golf. May be repeated three times for credit. This course has the option of a letter grade or credit/no credit.

4128 LAB GY200C KRAUSE S 10.00 2.0 DAILY 0200P-0400P

**ATH 38 Baseball****Transferable:** CSU; UC; CSU-GE: E1; GAV-GE: E1

This course provides practice and competition in intercollegiate baseball for men. May be repeated three times for credit. This course has the option of a letter grade or credit/no credit.

4129 LAB GY131G ANDRADEN 10.00 2.0 DAILY 0200P-0400P

**ATH 45 Softball****Transferable:** CSU; UC; CSU-GE: E1; GAV-GE: E1

This course provides practice and competition in intercollegiate softball for women. May be repeated three times for credit. This course has the option of a letter grade or credit/no credit.

4130 LAB GY131G DEQUINN 10.00 2.0 DAILY 0300P-0500P

**PHYSICAL SCIENCE****PSCI 1 Principles of Physical Science****Advisory:** Mathematics 205 and eligible for English 250 and 260.**Transferable:** CSU; UC; CSU-GE: B1; IGETC: 5A; GAV-GE: B1

An introduction to the physical sciences for the non-science major. Attention is focused on fundamental laws of nature, their development and relation to the physical world.

4691 LEC LS102 CLARK D 3.00 3.0 MW 1245P-0200P 1

**PSCI 2 Introduction to Meteorology****Advisory:** MATH 205.**Transferable:** CSU; GAV-GE: B1

An introductory course in Meteorology that is both descriptive and analytical on the physical principles affecting the earth's weather. Topics covered include the nature of the atmosphere, solar energy, heat, temperature, pressure, stability, moisture, wind, storms, severe weather and forecasting. The course introduces climatology as a scientific study and will look at the earth's climatic history, current research in climate modeling and the possibility of global climate change.

4754 ONLINE VANTUYL A 3.00 3.0 DHR 0000-0000

02/06/06 - 05/26/06

This online class will be delivered entirely over the internet. After enrolling, start the class by going to <http://www.gavilan.edu/disted/>, click on your class link, and email the instructor at [vantuyla@yahoo.com](mailto:vantuyla@yahoo.com). Students who have not begun the class or contacted the instructor by 5 pm on February 9 will be dropped from the class.

**PHYSICS****PHYS 1 Introduction to Physics****Advisory:** Mathematics 205.**Transferable:** CSU; UC; CSU-GE: B1, B3; IGETC: 5A; GAV-GE: B1, B3

This course is an introduction to the fundamental physical principles that control the world around us. Students will explore the fundamental principles of physics, their historical development, their application to everyday phenomena, and their impact upon political, social, and environmental issues. Laboratory exercises will explore the everyday world.

4678 L/L PH102 LEE R 6.00 4.0 TuTh 0945A-1225P 1

**Online Class****PSCI2 Introduction to Meteorology**

- Study in an area which makes news and impacts everyone every day.
- Capture the essence of the Information Age: developing problem solving skills based on current real-world data.
- Take part in exciting learning experiences without having to leave the comfort and convenience of your own home.
- Satisfy your Gavilan College general education requirement for physical science.

Section 4754

02/06/06 - 05/26/06

Instructor:

Andrew Vantuyl

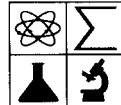
**MESA**

MATHEMATICS • ENGINEERING • SCIENCE ACHIEVEMENT

- ◆ Are you a math based major? (BIO, CSIS, Architecture, etc.)
- ◆ Do you want to transfer to a 4-year university?
- ◆ Do you have financial need? You may be eligible!

Gavilan's MESA Program is now accepting applications. MESA students are entitled to workshops, academic advising, field trips, tutoring and more!

For more information call 408-848-4887 or visit the MESA Study Center in PH 105.

◆ [www.gavilan.edu/MESA](http://www.gavilan.edu/MESA) ◆**assist**

MATH • ENGINEERING • SCIENCE MAJORS

**PLANNING TO TRANSFER?**

Admission for these majors is very competitive

**DID YOU KNOW?**

- ◆ 4-year universities stress preparation for the major over completion of general education
- ◆ High-unit majors do not need to fulfill all general education requirements
- ◆ You do not need to get an AA or AS degree to transfer
- ◆ You should plan your sequential courses early

ASSIST can help you plan your courses to complete major preparation prior to transfer.

Go to **www.assist.org**

AND see a counselor to develop an educational plan.



Sect.	Type	Room	Instructor	Hrs.	Units	Days	Begin-End	Footnotes
<b>PHYS 2B General Physics</b>								
<b>Prerequisite:</b> Physics 2A								
<b>Advisory:</b> Eligible for English 250 and English 260								
<b>Transferable:</b> CSU; UC; CSU-GE: B1, B3; IGETC: 5A; GAV-GE: B1, B3; CAN: PHYS 4, PHYS SEQ. A								
An introduction to the principles of physics using algebra and trigonometry. Topics include electricity and magnetism, light and optics, modern physics, and an introduction to relativity.								
4679	L/L	PH102	LEE R LEE R LEE R	6.00	4.0	MW W F	1110A-1225P 0210P-0400P 1110P-1200P	1

## POLITICAL SCIENCE

### POLS 1 Introduction to American Government

**Advisory:** Eligible for English 250 and English 260.

**Transferable:** CSU; UC; CSU-GE: D8; IGETC: 4H, 7A; GAV-GE: D1, D2; CAN: GOVT 2

Explores the development of American political institutions and their utilization in dealing with issues arising at the international, national and state levels. Emphasis is placed on those problems which have defined our federal system of government. California government and appropriate state institutions will be included as a vital part of our federal system of government.

4680	LEC	SS210	TURETZKY M	3.00	3.0	MW	0810A-0925A	
4681	LEC	SS210	TURETZKY M	3.00	3.0	TuTh	0810A-0925A	
4682	LEC	HOL6	ESCOVER M	3.00	3.0	TuTh	0900A-1015A	

**Above class meets at the Hollister Briggs site**

4753	LEC	S.BRAT	TEWES E	3.00	3.0	M	0330P-0620P	
------	-----	--------	---------	------	-----	---	-------------	--

**Above class meets at Sobrato High School, Bldg. 106**

4683	ONLINE	TURETZKY M		3.00	3.0	DHR	0000-0000	38
------	--------	------------	--	------	-----	-----	-----------	----



**This online class will be delivered entirely over the internet. After enrolling, start the class by going to <http://www.gavilan.edu/disted/>, click on your class link, and email the instructor at [mturetzky@gavilan.edu](mailto:mturetzky@gavilan.edu). Students who have not begun the class or contacted the instructor by 5 pm on January 26 will be dropped from the class.**

4684	ONLINE	TURETZKY M		3.00	3.0	DHR	0000-0000	38
------	--------	------------	--	------	-----	-----	-----------	----



**This online class will be delivered entirely over the internet. After enrolling, start the class by going to <http://www.gavilan.edu/disted/>, click on your class link, and email the instructor at [mturetzky@gavilan.edu](mailto:mturetzky@gavilan.edu). Students who have not begun the class or contacted the instructor by 5 pm on January 26 will be dropped from the class.**

### POLS 3 Introduction to Comparative Politics

**Advisory:** Eligible for English 250 and English 260.

**Transferable:** CSU; UC; CSU-GE: D8; IGETC: 4H; GAV-GE: D2, F

Comparative survey of political institutions and processes around the globe. Selected nations may include, but are not restricted to: the United Kingdom, France, Germany, Japan, Russia, India, Nigeria, and Mexico.

4685	LEC	SS205	TURETZKY M	3.00	3.0	TuTh	0945A-1100A	
------	-----	-------	------------	------	-----	------	-------------	--

### POLS 4 Introduction to International Relations

**Transferable:** CSU; UC; CSU-GE: D8; IGETC: 4H; GAV-GE: D2, F

This course provides an introduction to key contemporary international problems and the means to analyze them. Major parts of the course cover such topics as war and peace, foreign policymaking, the international economy, and future trends in world politics.

4686	LEC/online	SS205	TURETZKY M	3.00	3.0	M	0945A-1100A	13
------	------------	-------	------------	------	-----	---	-------------	----



**This HYBRID lecture/online class will be delivered partially over the internet. Come to the campus for the first day of class.**



### POLS 6 Introduction to Conflict Resolution

**Advisory:** English 250 and English 260.

**Transferable:** CSU; CSU-GE: D7; GAV-GE: D2

Introduction to Conflict Resolution introduces students to conflict resolution and mediation. Integrating theory and practice, students will assess core concepts about the causes and resolution of conflict, and will practice communication skills for conflict resolution. Students will examine how ethnicity, gender, and class affect power in conflict situations. They will be able to formulate appropriate conflict resolution strategies, and will develop and practice various basic co-mediation skills. This course has the option of a letter grade or credit/no credit. This course is also listed as AJ 6 and PSYC 6.

4687	LEC	SS216	HALPERL	3.00	3.0	TuTh	0945A-1100A	
------	-----	-------	---------	------	-----	------	-------------	--

Sect.	Type	Room	Instructor	Hrs.	Units	Days	Begin-End	Footnotes
<b>POLS 22 Field Work and Service</b>								
<b>Required:</b> Learning contracts must be filled out and signed by the student and the supervising instructor.								
<b>Transferable:</b> CSU								
Supervised field work within the college and with local agencies. Students serve in useful group activities in leadership roles prescribed for them by faculty or community agencies. A maximum of six units may be completed. This is a credit/no credit course.								
4688	FEX	SS107	TURETZKY M	3.00	1.0	DHR	0000-0000	21

### POLS 23 Independent Study

**Required:** The study outline prepared by the student and the instructor must be filed with the department and the dean.

**Transferable:** CSU

Designed to afford selected students specialized opportunities for exploring areas at the independent study level. The courses may involve extensive library work, research in the community, or special projects. May be repeated until six units of credit are accrued. This course has the option of a letter grade or credit/no credit.

4689	IND	SS107	TURETZKY M	3.00	1.0	DHR	0000-0000	22
4690	IND	SS107	TURETZKY M	6.00	2.0	DHR	0000-0000	22

## PSYCHOLOGY

### PSYC 1A Introduction to Psychology

**Advisory:** Eligible for English 250 and English 260.

**Transferable:** CSU; UC; CSU-GE: D9; IGETC: 4I; GAV-GE: D2; CAN: PSY 2

The nature, scope, methods, presuppositions, history, and fields of psychology together with the scientific study of factors influencing human behavior, human development, perception, learning, memory, emotion, personality, frustration, and psychotherapy.

4692	LEC	SS214	BOYCE C	3.00	3.0	MW	0810A-0925A	
4693	LEC	SS214	HINN G	3.00	3.0	TuTh	0810A-0925A	
4694	LEC	MHG3	BALES N	3.00	3.0	TuTh	1030A-1145A	

**Above class meets at Morgan Hill Community site**

4695	LEC	SS210	CAMPILLI J	3.00	3.0	MW	0215P-0330P	
6155	LEC	SS214	CAMPILLI J	3.00	3.0	M	0600P-0850P	
6156	LEC	HOL5	BOYCE C	3.00	3.0	Tu	0600P-0850P	

**Above class meets at the Hollister Briggs site**

### PSYC 1B Introduction to Psychology

**Advisory:** Psychology 1A

**Transferable:** CSU; UC; CSU-GE: D9; IGETC: 4I; GAV-GE: D2

Continuation of Psychology 1A. This course stresses the biological basis of behavior including: neuroanatomy, the senses, perception, learning, thinking, and psychological disorders.

4696	L/L	SS110	BALES N	3.00	3.0	MW	0945A-1100A	
------	-----	-------	---------	------	-----	----	-------------	--

### PSYC 2 Early Child Development

**Advisory:** Eligible for English 250 and English 260.

**Transferable:** CSU; UC; CSU-GE: D9, E; IGETC: 4I; GAV-GE: D2

A systematic study of the child from prenatal life through the preschool years. The course integrates the basic concepts of physical, cognitive and psychosocial development at each major stage of life during this period. This course is also listed as CD 2. This course has the option of a letter grade or credit/no credit.

4697	LEC/online	SS210	CLABAUGH D	3.00	3.0	TuTh	1110A-1220P	13 25
------	------------	-------	------------	------	-----	------	-------------	-------



**This HYBRID lecture/online class will be delivered partially over the internet. Come to the campus for the first day of class.**

4698	ONLINE	BUMGARNER M		3.00	3.0	DHR	0000-0000	25 38
------	--------	-------------	--	------	-----	-----	-----------	-------



**This online class will be delivered entirely over the internet. After enrolling, start the class by going to <http://www.gavilan.edu/disted/>, click on your class link, and email the instructor at [mbumgarner@gavilan.edu](mailto:mbumgarner@gavilan.edu). Students who have not begun the class or contacted the instructor by 5 pm on January 26 will be dropped from the class.**

6157	LEC	SS205	SHARPE E	3.00	3.0	Th	0630P-0920P	25 34
------	-----	-------	----------	------	-----	----	-------------	-------

**Esta sección sera enseñada en Español.**

Sect.	Type	Room	Instructor	Hrs.	Units	Days	Begin-End	Footnotes
-------	------	------	------------	------	-------	------	-----------	-----------

### PSYC 3 Child Growth and Development During the School Years

**Advisory:** Eligible for English 250 and English 260; Psychology 2.

**Transferable:** CSU; UC; CSU-GE: D9, E ; IGETC: 4I; GAV-GE: D2

Continuation of the study of child development with emphasis on children from six years of age through adolescence. Includes developmental theories and topics relevant to these ages. This course is also listed as CD 3. This course has the option of a letter grade or credit/no credit.

4699	LEC	MHG4	BUMGARNER M	3.00	3.0	MW	1030A-1145A	25
------	-----	------	-------------	------	-----	----	-------------	----

Above class meets at Morgan Hill Community site

6158	LEC	HOL2	BROWN R	3.00	3.0	M	0600P-0850P	25
------	-----	------	---------	------	-----	---	-------------	----

Above class meets at the Hollister Briggs site

### PSYC 5 Self-Assessment and Career Development

**Advisory:** Eligible for English 250 and English 260.

**Transferable:** CSU; CSU-GE: E2; GAV-GE: E2

A course designed to assist the student in learning more about personal values, personality, interests, exploration of career choice, and occupational opportunities through the use of various personal assessment instruments. The delivery options for this course include online and self-paced formats.

This course is also listed as GUID 1.

4700	ONLINE	STAFF		4.00	2.0	DHR	0000-0000	25 38 89
------	--------	-------	--	------	-----	-----	-----------	----------

**03/6/06 - 05/5/06** This online class will be delivered entirely over the internet. After enrolling, start the class by going to <http://www.gavilan.edu/disted/>, click on your class link, and email the instructor at xxxxxxx@gavilan.edu. Students who have not begun the class or contacted the instructor by 5 pm on March 11 will be dropped from the class.



### PSYC 6 Introduction to Conflict Resolution

**Advisory:** English 250 and English 260.

**Transferable:** CSU; CSU-GE: D7; GAV-GE: D2

Introduction to Conflict Resolution introduces students to conflict resolution and mediation. Integrating theory and practice, students will assess core concepts about the causes and resolution of conflict, and will practice communication skills for conflict resolution. Students will examine how ethnicity, gender, and class affect power in conflict situations. They will be able to formulate appropriate conflict resolution strategies, and will develop and practice various basic co-mediation skills. This course has the option of a letter grade or credit/no credit. This course is also listed as AJ 6 and POLS 6.

4758	LEC	SS216	HALPERL	3.00	3.0	TuTh	0945A-1100A	
------	-----	-------	---------	------	-----	------	-------------	--

### PSYC 22 Field Work and Service

**Required:** Learning contracts must be filled out and signed by the student and the supervising instructor.

**Transferable:** CSU

Supervised field work within the college and with local agencies. Students serve in useful group activities in leadership roles prescribed for them by faculty or community agencies. A maximum of six units may be completed. This is a credit/no credit course.

4701	FEX	SS109	HINNG	3.00	1.0	DHR	0000-0000	21
------	-----	-------	-------	------	-----	-----	-----------	----

### PSYC 23 Independent Study

**Required:** The study outline prepared by the student and the instructor must be filed with the department and the dean.

**Transferable:** CSU

Designed to afford selected students specialized opportunities for exploring areas at the independent study level. The courses may involve extensive library work, research in the community, or special projects. May be repeated until six units of credit are accrued. This course has the option of a letter grade or credit/no credit.

4704	IND	SS109	HINNG	6.00	2.0	DHR	0000-0000	22
------	-----	-------	-------	------	-----	-----	-----------	----

### PSYC 41 Psychology of Adjustment

**Advisory:** Eligible for English 250 and English 260.

**Transferable:** CSU; CSU-GE: E2; GAV-GE: E2

Analysis of personal interactions, process of personal adjustment, frustration and defense mechanisms, assertive behavior, values clarification and the goals of individual behavior.

4707	LEC	SS110	HINNG	2.00	2.0	TuTh	1100A-1200P	
------	-----	-------	-------	------	-----	------	-------------	--

### PSYC 52 Peer Counseling

**Advisory:** Eligible for English 250 and English 260.

**Transferable:** CSU

An overview of the principles, skills, and methods used in peer counseling. Course emphasizes using communication skills, goal setting, intervention techniques and evaluation for peer counselors and others.

4708	LEC	HU101	LISTER T	2.00	2.0	TuTh	0110P-0200P	
------	-----	-------	----------	------	-----	------	-------------	--

Sect.	Type	Room	Instructor	Hrs.	Units	Days	Begin-End	Footnotes
-------	------	------	------------	------	-------	------	-----------	-----------

## 5 great reasons to take Intro to Conflict Resolution!

- 1. It's rewarding.** You help people solve real problems, and their lives improve.
- 2. It's interesting.** Every case is different and challenging.
- 3. It pays off.** In your work, school, and relationships, you can use the skills.
- 4. It's great for your resume,** demonstrating that you work well with others.
- 5. It's changing the world.** Join the growing numbers people working to solve conflict peacefully and cooperatively.



Great reasons. Great skills. Great class.

## Political Science 6

### Introduction to Conflict Resolution

You can also register for AJ 6 and PSYC 6.

(AJ 6 provides elective credit for AJ majors)

Sect. 4687

3 units TuTh 9:45 - 11:00 am Instructor: Leah Halper

This class fulfills Gavilan general education and CSU transfer requirements.

## POLS 4: INTRODUCTION TO INTERNATIONAL RELATIONS



This class is for you if you have ever wondered:

- Why people around the globe are still killing each other?
- Why billions of our global neighbors live in extreme poverty while we live in relative wealth?
- Why global weather patterns seem to be worsening?
- Whether saddam hussein ever really had possession of wmd?
- Whether the world is closer than ever to nuclear armageddon?

*If you are interested in answers to questions like these (and more) then this is the class for you!*

**\*\*It also fulfills graduation and uc and csu transfer requirements!!**

**PROFESSOR:** Dr. Marc Turetzky

**SECTION:** 4686

**DAYS & TIME:** M, 9:45-11

**ROOM:** SS205

*This is a HYBRID course. It meets only one day per week in person, the other day online.*



## Brush Up your Software Skills

Most Computer Applications classes are repeatable.

Sect.	Type	Room	Instructor	Hrs.	Units	Days	Begin-End	Footnotes
-------	------	------	------------	------	-------	------	-----------	-----------

### Physiology: See Biological Sciences

### Public Speaking: See Communications

## REAL ESTATE

### RE 160 Real Estate Principles

**Advisory:** Eligible for English 250, English 260 and Mathematics 205.

**Transferable:** CSU

The fundamental course covering an introduction to the field of real estate. Provides understanding, background and terminology necessary for advanced specialized courses. Will meet requirements for the Real Estate Sales License.

6159	LEC	BU118	FRIMANN G	3.00	3.0	Tu	0630P-0920P
------	-----	-------	-----------	------	-----	----	-------------



### RE 162 Real Estate Practice

**Advisory:** Real Estate 160

**Transferable:** CSU

Introduction to the practice of real estate in California; emphasis on the practical application of listings, selling, advertising, financing, escrow, taxation, and valuation of real estate. This course meets a requirement for the California Broker's License.

6160	LEC	BU120	FRIMANN G	3.00	3.0	Th	0630P-0920P
------	-----	-------	-----------	------	-----	----	-------------

### Skin Care: See COS 220, 221

## SOCIAL SCIENCES, GENERAL



### SSCI 270B Introduction to the Social Sciences

**Advisory:** Eligible for English 250.

**Transferable:** No; GAV-GE: A3

An introduction to key concepts, principles, frameworks and issues in the major social science disciplines of psychology, sociology, and anthropology for students wishing to get a broad overview. Development of techniques and practice in research, reasoning, writing, topical reading, and critical analytical skills germane to the understanding of individuals, groups, and societies will be emphasized so students will build skills to think critically about contemporary policies and practices of groups, societies, and governments. This course has the option of a letter grade or credit/no credit.

4725	LEC	SS205	STAFF	3.00	3.0	MW	1110A-1225P
------	-----	-------	-------	------	-----	----	-------------

## SOCIOLOGY

### SOC 1A Introduction to Sociology

**Advisory:** Eligible for English 250 and English 260.

**Transferable:** CSU; UC; CSU-GE: D0; IGETC: 4J; GAV-GE: D2; CAN: SOC 2

Analysis of the structure and dynamics of human society focusing on the development of culture, the socialization process, group behavior, social inequality, deviance, sexism, racism, and ageism, major social institutions, and human ecology. Emphasizes contemporary American society.

4709	LEC	MHG3	BALES N	3.00	3.0	TuTh	0900A-1015A
------	-----	------	---------	------	-----	------	-------------

**Above class meets at Morgan Hill Community site**

4710	LEC	CJ500	MOORE M	3.00	3.0	TuTh	0945A-1100A
------	-----	-------	---------	------	-----	------	-------------

6161	LEC	HOL1	FAUTT M	3.00	3.0	M	0630P-0920P
------	-----	------	---------	------	-----	---	-------------

**Above class meets at the Hollister Briggs site**

### SOC 1B Introduction to Sociology: Social Problems

**Advisory:** Sociology 1A

**Transferable:** CSU; UC; CSU-GE: D0; IGETC: 4J; GAV-GE: D2; CAN: SOC 4

Sociology 1B is a course centering on the application of sociological concepts to the analysis of human ecology, social movements, social change, deviance and other selected social problems. Emphasis is placed on the study and analysis of problems in contemporary American society.

4711	LEC	CJ500	MOORE M	3.00	3.0	TuTh	1110A-1225P
------	-----	-------	---------	------	-----	------	-------------

Sect.	Type	Room	Instructor	Hrs.	Units	Days	Begin-End	Footnotes
-------	------	------	------------	------	-------	------	-----------	-----------

### SOC 4 Sociology of Women and Men

**Advisory:** Eligible for English 250 and English 260.

**Transferable:** CSU; UC; CSU-GE: D0, D4; IGETC: 4J; GAV-GE: D2

Analysis of the nature of women's and men's traditional and changing roles in society including development of women's and men's potential, relationships in marriage, influence of mass media, employment practices, legal provisions and women's and men's liberation.

6162	LEC	SS210	FAUTT M	3.00	3.0	Th	0630P-0920P
------	-----	-------	---------	------	-----	----	-------------

### SOC 10 Mass Media and Society

**Advisory:** English 250, English 260

**Transferable:** CSU; UC; CSU-GE: C2, D0; IGETC: 4J; GAV-GE: C2, D2

This course helps us understand the 20th century revolution in mass media by focusing on the history, economics and social impact of the newspaper, book publishing, magazine, film, television, public relations, advertising and music industries. We will study audience, propaganda and mass communication theory; we will discuss new technology, ethnic media in the U.S., ethical issues and attempts to regulate or control the media. Honors students will complete more in-depth analysis of media issues, and will finish a media-related research project. This course is also listed as JOUR 10. This course has the option of a letter grade or credit/no credit.

4712	LEC	SS205	STAFF	3.00	3.0	TuTh	0215P-0330P
------	-----	-------	-------	------	-----	------	-------------

### SOC 21 Marriage and the Family

**Advisory:** Eligible for English 250 and English 260.

**Transferable:** CSU; CSU-GE: E2; GAV-GE: E2

Survey of information on preparation for marriage, including dating, courtship, engagement, mate selection, adjustment and parenthood. Time will also be spent on the study of families and how they function.

4713	LEC	HOL2	STAFF	3.00	3.0	TuTh	0900A-1015A
------	-----	------	-------	------	-----	------	-------------

**Above class meets at the Hollister Briggs site**

4714	LEC	SS214	HINN G	3.00	3.0	TuTh	0945A-1100A
------	-----	-------	--------	------	-----	------	-------------

6163	LEC	HOL5	SILVERSTEIN	3.00	3.0	Th	0630P-0920P
------	-----	------	-------------	------	-----	----	-------------

**Above class meets at the Hollister Briggs site**

## SPANISH

### SPAN 1A Elementary Spanish

**Transferable:** CSU; UC; CSU-GE: C2; GAV-GE: C2; CAN: SPAN 2, SPAN SEQ. A

Beginning course with emphasis on understanding and speaking Spanish; introduction to reading and writing Spanish. This course will also introduce students to Hispanic culture and institutions.

4715	L/L	HU105	MARQUES A	7.50	5.0	MTuWTh&2.5	0820A-0925A
------	-----	-------	-----------	------	-----	------------	-------------

4716	L/L	HOL5	PEREZ D	7.50	5.0	MTuWTh&2.5	0900A-1005A
------	-----	------	---------	------	-----	------------	-------------

**Above class meets at the Hollister Briggs site**

4718	L/L	HU105	MARQUES A	7.50	5.0	MTuWTh&2.5	1110A-1215P
------	-----	-------	-----------	------	-----	------------	-------------

6164	L/L	MHG13	LEMOS C	7.50	5.0	M W&2.5	0530P-0920P
------	-----	-------	---------	------	-----	---------	-------------

**Above class meets at Morgan Hill Community site**

### SPAN 1B Elementary Spanish

**Advisory:** Spanish 1A or equivalent.

**Transferable:** CSU; UC; CSU-GE: C2; IGETC: 6A; GAV-GE: C2; CAN: SPAN 4, SPAN SEQ. A

Continuation of Spanish 1A. Further development of the four skills of understanding, speaking, reading and writing Spanish. This course will continue to emphasize the study of Hispanic culture and institutions.

4719	L/L	HOL6	PEREZ D	7.50	5.0	MTuWTh&2.5	1015A-1120A
------	-----	------	---------	------	-----	------------	-------------

**Above class meets at the Hollister Briggs site**

4720	L/L	HU105	PEREZ D	7.50	5.0	MTuWTh&2.5	1245P-0150P
------	-----	-------	---------	------	-----	------------	-------------

### SPAN 2B Intermediate Spanish

**Advisory:** Spanish 2A or equivalent.

**Transferable:** CSU; UC; CSU-GE: C2; IGETC: 3B; GAV-GE: C2; CAN: SPAN 10, SPAN SEQ. B

Review of basic structures and grammar with greater emphasis on vocabulary and idioms. Introduction to literature as it reflects the characteristics of Hispanic societies. Greater emphasis on composition as a medium of expression.

4721	L/L	HU105	MARQUES A	7.50	5.0	MTuWTh&2.5	0945A-1050A
------	-----	-------	-----------	------	-----	------------	-------------

Sect. Type Room Instructor Hrs. Units Days Begin-End Footnotes

**SPAN 8A Conversational Spanish****Transferable:** CSU; GAV-GE: C2

This course is a beginning Spanish course, focusing on the Spanish sound system, basic grammar and vocabulary, and cultural elements. Although emphasis is on listening and speaking, basic reading and writing skills will be developed.

6165	LEC	HOL6	POLO I	3.00	3.0	M	0630P-0920P
<b>Above class meets at the Hollister Briggs site</b>							
6166	LEC	HU103	PEREZ D	3.00	3.0	Th	0630P-0920P

**SPAN 8B Conversational Spanish****Advisory:** Spanish 8A or equivalent.**Transferable:** CSU; GAV-GE: C2

This course requires knowledge of Spanish pronunciation, basic vocabulary, and present tense grammar. More advanced grammar and vocabulary, and cultural elements will be taught in the development of listening, speaking, basic reading and writing skills.

6167	LEC	HU105	SCHMIDT E	3.00	3.0	M	0630P-0920P
------	-----	-------	-----------	------	-----	---	-------------

**SPAN 8C Conversational Spanish****Advisory:** Spanish 8B or equivalent.**Transferable:** CSU; GAV-GE: C2

This course requires considerable knowledge of Spanish pronunciation, vocabulary, grammar and syntax. More advanced grammar and vocabulary will be taught in the development of listening, speaking, reading and writing skills.

6168	LEC	HU103	MAGUNA J	3.00	3.0	Tu	0630P-0920P
------	-----	-------	----------	------	-----	----	-------------

**SPAN 8D Conversational Spanish****Advisory:** Spanish 8C or equivalent.**Transferable:** CSU; GAV-GE: C2

This course requires fluency in spoken and written Spanish. Advanced grammar and vocabulary will be presented while the course concentrates on polishing the student's oral and written skills and develops a sense of style.

6169	LEC	HU103	MAGUNA J	3.00	3.0	Tu	0630P-0920P
------	-----	-------	----------	------	-----	----	-------------

**SPAN 12A Spanish for Spanish Speakers****Advisory:** Basic Spanish reading and writing skills.**Transferable:** CSU; UC; CSU-GE: C2; GAV-GE: C2, F

Through comparative analysis of selected literary works, the course develops an awareness of cultural and literary contributions from Mexico and other Spanish speaking societies. The course is taught in Spanish with emphasis on composition as a medium of expression.

4722	L/L	ONLINE	PEREZ D	7.50	5.0	DHR	0000-0000	38
------	-----	--------	---------	------	-----	-----	-----------	----

**This online class will be delivered entirely over the internet. After enrolling, start the class by going to <http://www.gavilan.edu/disted/>, click on your class link, and email the instructor at [dperez@gavilan.edu](mailto:dperez@gavilan.edu). Students who have not begun the class or contacted the instructor by 5 pm on January 26 will be dropped from the class.**

**SPAN 23 Independent Study****Required:** The study outline prepared by the student and the instructor must be filed with the department and the dean.**Transferable:** CSU

Designed to afford selected students specialized opportunities for exploring areas at the independent study level. The courses may involve extensive library work, research in the community, or special projects. May be repeated until six units of credit are accrued. This course has the option of a letter grade or credit/no credit.

4723	IND	HU108	PEREZ D	6.00	2.0	DHR	0000-0000	21
4724	IND	HU110	MARQUES A	6.00	2.0	DHR	0000-0000	21
6170	IND	HU103	MAGUNA J	6.00	2.0	Tu&6	0630P-0920P	21

**Speech: See Communications****Statistics: See Mathematics**

Sect. Type Room Instructor Hrs. Units Days Begin-End Footnotes

**ASB** Associated Student Body

**Today-Shaping the policies of the college.  
Tomorrow-Shaping the policies of the world.**

**Join Student Government**  
(408) 848-4777

**ojo**  **(look)**

Do you know what *gavilán* means?  
Take **Spanish** at Gavilan and find out.

Gavilan College has one of the most outstanding Spanish programs in California.

Gavilan has state of the art software that is self-paced to enhance and facilitate the learning experience.

Gavilan has a listening lab and offers tutoring.

All levels are offered from beginning to native speaker.

**FACULTY** Profile**GARY FRIMANN:**

Real Estate Broker Gary Frimann started his Real Estate career in 1986 as a loan officer for Security Pacific Bank. Subsequently, he went to work for a mortgage brokerage, and in 2001 started his own residential brokerage company and a mortgage company, recently furthering his pursuits in commercial brokerage.

"So far, I've enjoyed my teaching experience at Gavilan very much," says Frimann. "I teach a subject that generates a tremendous amount of interest." His class is a mixture of all ages and has a large percentage of people returning to take the required college level courses to sit for the State Exam. "I have many students who are looking for a career change. I like to teach not only the 'nuts and bolts' of the subject matter, but delve into the recent past, as the profession and the laws governing it are in a constant state of change."



Sect. Type Room Instructor Hrs. Units Days Begin-End Footnotes

**THEATRE ARTS / DRAMA****THEA 1 Theatre History****Advisory:** Eligible for English 250 and English 260.**Transferable:** CSU; UC; CSU-GE: C2; IGETC: 3A; GAV-GE: C2, F

A survey of the history of theatrical performance, production and dramatic literature, including: early Greek, Roman, Asian, the Renaissance, Italian, English, modern European to contemporary American theatre.

4726 ONLINE THOMPSON R 3.00 3.0 DHR 0000-0000

 **This online class will be delivered entirely over the internet. After enrolling, start the class by going to <http://www.gavilan.edu/disted/>, click on your class link, and email the instructor at [rthompson@gavilan.edu](mailto:rthompson@gavilan.edu). Students who have not begun the class or contacted the instructor by 5 pm on January 26 will be dropped from the class.**

**THEA 3 El Teatro Campesino****Advisory:** Eligible for English 250 and English 260.**Transferable:** CSU; UC; GAV-GE: C1

Reading, viewing and discussing the work of writer/director Luis Valdez and El Teatro Campesino (The Farmworkers Theatre) is the focus of this course. It traces the historical development of the theatrical company from its creation in 1965 to the present. Students will read actos, plays and view theatrical productions performed by El Teatro Campesino. This course has the option of a letter grade or credit/no credit.

4727 ONLINE ABAD M 3.00 3.0 DHR 0000-0000 38

 **03/06/06 - 05/26/06 This online class will be delivered entirely over the internet. After enrolling, start the class by going to <http://www.gavilan.edu/disted/>, click on your class link, and email the instructor at [mabad@gavilan.edu](mailto:mabad@gavilan.edu). Students who have not begun the class or contacted the instructor by 5 pm on March 11 will be dropped from the class.**

**THEA 4 Oral Reading****Advisory:** Eligible for English 250 and English 260.**Transferable:** CSU; UC; CSU-GE: C1; GAV-GE: C1

An introduction to the analysis, preparation and dramatic reading of literature, including classical and contemporary prose, poetry and drama. Students prepare, analyze and orally present and interpret great works of drama and literature for an audience. This course is also listed as CMUN 2.

4728 LEC TH125 THOMPSON R 3.00 3.0 MW 1110A-1225P 25

**THEA 7 Introduction to Theatre****Transferable:** CSU; UC; CSU-GE: C1; IGETC: 3A; GAV-GE: C1

This learning experience examines how theatre productions are staged and created. Elements of theatrical production including: writing, producing, directing, designing, and acting will be explored.

4729 ONLINE PALMA J 3.00 3.0 DHR 0000-0000 38

 **This online class will be delivered entirely over the internet. After enrolling, start the class by going to <http://www.gavilan.edu/disted/>, click on your class link, and email the instructor at [jpalma@gavilan.edu](mailto:jpalma@gavilan.edu). Students who have not begun the class or contacted the instructor by 5 pm on January 26 will be dropped from the class.**

**THEA 12A Acting: History and Practice****Transferable:** CSU; UC; CSU-GE: C1; GAV-GE: C1; CAN: DRAM 8

An introduction to the historical development of acting as a practice of human cultural expression. Students will acquire a vocabulary for theatre performance as an art form and analyze dramatic works in a historical context. Practice of basic acting concepts, character analysis, preparation and performances of monologues and scenes will be required in the course.

4730 L/L TH125 PALMA J 5.00 3.0 TuTh&amp;2 1110A-1225P

**THEA 12B Acting Techniques****Advisory:** Theatre Arts 12A.**Transferable:** CSU; UC; GAV-GE: C1

Techniques for creating characterizations for performance. Various acting approaches will be examined through research, discussion and acting exercises. This course has the option of a letter grade or credit/no credit. May be repeated two times for credit.

4731 L/L TH125 PALMA J 4.00 2.0 TuTh&amp;1 1110A-1225P

**THEA 13A Actor's Workshop****Transferable:** CSU; UC; GAV-GE: C1

Audition, rehearsal and performance of a theatrical production for public performance.

6171 LAB TH125 CARDINALLI J 12.00 3.0 MTuWTh 0630P-0920P 11

01/23/06 - 04/10/06

Sect. Type Room Instructor Hrs. Units Days Begin-End Footnotes

**THEA 13B Actor's Workshop****Transferable:** CSU; UC; GAV-GE: C1

Audition, rehearsal and performance of a theatrical production for public performance.

6172 LAB TH125 CARDINALLI J 12.00 3.0 MTuWTh 0630P-0920P 11

CHAVEZ D

01/23/06 - 04/10/06

**THEA 13C Actor's Workshop****Advisory:** THEA 13B.**Transferable:** CSU; UC; GAV-GE: C1

Audition, rehearsal and performance of a theatrical production for public performance.

6173 LAB TH125 ABAD M 12.00 3.0 MTuWTh 0630P-0920P 11

01/23/06 - 04/10/06

**THEA 13D Actor's Workshop****Advisory:** Theatre Arts 13C**Transferable:** CSU; UC; GAV-GE: C1

Audition, rehearsal and performance of a theatrical production for public performance.

6174 LAB TH125 CARDINALLI J 12.00 3.0 MTuWTh 0630P-0920P 11

01/23/06 - 04/10/06

**THEA 14 Stage Production****Advisory:** Eligible for English 250 and English 260.**Transferable:** CSU; UC; GAV-GE: C1

An individualized course in technical theatre production for the performing arts. Areas of study include: scenery, lighting, props, costumes, sound, make-up, public relations/box office management or stage management. May be repeated until a maximum of 9 units are accrued.

4732 LAB TH125 THOMPSON R 6.00 2.0 MW&amp;2 1245P-0235P

01/23/06 - 05/17/06

**THEA 16 Introduction to Television****Advisory:** Eligible for English 250 and 260.**Transferable:** CSU; GAV-GE: C1

An introductory course on the history of television as a major communications tool. Students will learn skills for effective script writing, production techniques, and post-production procedures.

4733 LEC LI144 FRAZIER J 3.00 3.0 TuTh 0945A-1100A

**THEA 17A Television and Video Workshop****Advisory:** Theatre Arts 16 Intro to TV or consent of instructor.**Transferable:** CSU; GAV-GE: C1

An introduction to television and video technology, including pre-production, production and post-production techniques such as: camera work, studio equipment, lighting, audio plus off-line and on-line editing.

4734 L/L LI144 FRAZIER J 5.00 3.0 TuTh 1245P-0300P

**THEA 17B Television and Video Workshop****Advisory:** Completion of Theatre Arts 17A.**Transferable:** CSU; GAV-GE: C1

Emphasis placed on production and post-production techniques in video production. Student knowledge and skills are increased by participating in live to tape projects. May be repeated twice for credit.

4735 LEC LI144 FRAZIER J 5.00 3.0 TuTh 1245P-0300P

**THEA 19 Television and Film Acting****Transferable:** CSU; UC; GAV-GE: C1

Theory and practice of acting for film and television. Students will learn basic performance techniques for the camera. Learning experiences include projects in broadcasting, reporting, commercials, public service announcements (psa), comedy and drama. This course has the option of a letter grade or credit/no credit. May be repeated three times for credit.

4736 L/L LI144 ABAD M 5.00 3.0 MW&amp;2 0945A-1100A

Sect. Type Room Instructor Hrs. Units Days Begin-End Footnotes

**THEA 20 Introduction to Scriptwriting**

**Advisory:** English 250  
**Transferable:** CSU  
 An introductory course on script development, writing and formatting for broadcast television and film production. This course has the option of a letter grade or credit/no credit.

4737	ONLINE	ABAD M	3.00	3.0	DHR	0000-0000	20 38
------	--------	--------	------	-----	-----	-----------	-------

**This online class will be delivered entirely over the internet. After enrolling, start the class by going to <http://www.gavilan.edu/disted/>, click on your class link, and email the instructor at [mabad@gavilan.edu](mailto:mabad@gavilan.edu) or [grichards@gavilan.edu](mailto:grichards@gavilan.edu). Students who have not begun the class or contacted the instructor by 5 pm on January 26 will be dropped from the class.**

**THEA 22 Field Work and Service**

**Required:** Learning contracts must be filled out and signed by the student and the supervising instructor.  
**Transferable:** CSU  
 Supervised field work within the college and with local agencies. Students serve in useful group activities in leadership roles prescribed for them by faculty or community agencies. A maximum of six units may be completed. This is a credit/no credit course.

4738	FEX	TH125	ABAD M	3.00	1.0	DHR	0000-0000	21
------	-----	-------	--------	------	-----	-----	-----------	----

**THEA 23 Independent Study**

**Required:** The study outline prepared by the student and the instructor must be filed with the department and the dean.  
**Transferable:** CSU  
 Designed to afford selected students specialized opportunities for exploring areas at the independent study level. The courses may involve extensive library work, research in the community, or special projects. May be repeated until six units of credit are accrued. This course has the option of a letter grade or credit/no credit.

4739	IND	TH125	ABAD M	3.00	1.0	DHR	0000-0000	22
4740	IND	TH125	ABAD M	6.00	2.0	DHR	0000-0000	22
4741	IND	LH141	CARDINALLI J	3.00	1.0	DHR	0000-0000	22
4742	IND	LH141	CHAVEZ D	6.00	2.0	DHR	0000-0000	22
4743	IND	TH125	FRAZIER J	3.00	1.0	DHR	0000-0000	22
4744	IND	TH125	FRAZIER J	6.00	2.0	DHR	0000-0000	22
4745	IND	TH125	PALMA J	3.00	1.0	DHR	0000-0000	22
4746	IND	TH125	PALMA J	6.00	2.0	DHR	0000-0000	22

**THEA 98 Special Topics: GavTV 18**

**Transferable:** CSU  
 Special topics courses examine current problems or issues of interest to students within a specific discipline area. For topical content information, consult with the appropriate department chairperson. For transfer status, check with a counselor. This course may have the option of a letter grade or credit/no credit.

4747	LEC	OE003	ABAD M	1.00	1.0	Tu	1110A-1200P
4748	LEC	OE003	ABAD M	2.00	2.0	Tu&1	1110A-1200P

**VOCATIONAL PREPARATION FOR DISABLED**

**AE 600 Vocational Training I**

**Transferable:** No  
 Prevocational skills for adults with impaired cognitive functioning. Entry level work preparation is emphasized. Skills taught include basic work routine orientation, communication skills, job ability assessment, and self-management skills.

4008	LAB	LI204	FRANKLIN L	22.00	.0	DHR	0000-0000	31 75
4009	LAB	HOPE-G	MERRILL	30.00	.0	DHR	0000-0000	31 63 75
<b>See Footnote: Above class meets Off Campus</b>								
4010	LAB	HOPE-H	BROWN C	30.00	.0	DHR	0000-0000	31 51 75
<b>See Footnote: Above class meets Off Campus</b>								
4011	LAB	MHG10	MERRILL	4.00	.0	M	0910A-1000A	31
			MERRILL				1010A-1110A	
			MERRILL				1110A-1210P	
			MERRILL				1210P-0100P	
4012	LAB	LI171	SATO K	2.00	.0	TuTh	0910A-1000A	31 75
4013	LAB	LI117	MERRILL	7.00	.0	W	0910A-0400P	31 75
4014	LAB	APE101	SATO K	2.00	.0	TuTh	1010A-1100A	31 75
4015	LAB	APE120	BROWN C	2.00	.0	TuTh	1110A-1200P	31 75
		APE121	BROWN C					

Sect. Type Room Instructor Hrs. Units Days Begin-End Footnotes



*Enter the world of live entertainment!!!*

*Everyone is invited to participate!*

**THEA 13 A-D Actor's Workshop** Presents  
 an exciting play with music!

**Blood Wedding** by Frederico Garcia Lorca

*Directed by David J. Chavez \* Production Designer: Joe Cardinalli*

Sects. 6171-6174 MTWTh 6:30-9:20 pm TH 125

*For more information call 408-848-4764*



**THEA 3 sect. 4727 El Teatro Campesino**



Learn the history! Study the literature and films of writer/director Luis Valdez.

with **Marilyn Abad-Cardinalli**  
 March 6 - May 26

**GAVTV 18**  
 What is The Gavilan Educational Station

*Be a part of the cameras, lights, action. Enroll in:*

<b>THEA 16</b>	Introduction to Television
<b>THEA 17A/B</b>	Television and Video Workshop
<b>THEA 19</b>	Television and Film Acting
<b>THEA 20</b>	Introduction to Scriptwriting



**Get Involved!**  
 Sign up for

**THEA 98 - GAVTV 18**

- Learn all aspects of TV programming
  - Be a studio production crew member
  - Produce and create your own GAV-TV program
- 2 Sections - see class listing on this page.

For more information call Executive Producer Marilyn Abad-Cardinalli at 408-848-4764 or visit [www.gavilan.edu](http://www.gavilan.edu) click on GavTV 18.

Sect.	Type	Room	Instructor	Hrs.	Units	Days	Begin-End	Footnotes
-------	------	------	------------	------	-------	------	-----------	-----------

**AE 602 Vocational Training III**

Transferable: No

Practical training and on-the-job work experience for students with disabilities. This course also provides preparation for entry level employment utilizing a number of work alternatives and settings.

4016	LAB	HOPE-H	SATOK	30.00	.0	DHR	0000-0000	31 51 75
------	-----	--------	-------	-------	----	-----	-----------	----------

See Footnote: Above class meets Off Campus

4017	LAB	LI204	FRANKLIN L	30.00	.0	DHR	0000-0000	31 75
------	-----	-------	------------	-------	----	-----	-----------	-------

4018	LAB	HOPE-G	MERRILL BROWN C	30.00	.0	DHR	0000-0000	31 63 75
------	-----	--------	--------------------	-------	----	-----	-----------	----------

See Footnote: Above class meets Off Campus

4019	LAB	HOPE-G	LOPEZ F	30.00	.0	DHR	0000-0000	31 63 75
------	-----	--------	---------	-------	----	-----	-----------	----------

01/03/06 - 01/19/06 See Footnote: Above class meets Off Campus

4020	LAB	HOPE-H	LOPEZ F	30.00	.0	DHR	0000-0000	31 51 75
------	-----	--------	---------	-------	----	-----	-----------	----------

01/03/06 - 01/19/06 See Footnote: Above class meets Off Campus

**AE 603 Vocational Training IV**

Transferable: No

AE 603 is a job readiness course which provides opportunities for individuals with disabilities to participate in service-learning activities and job readiness training leading to job development and placement in a community setting.

4021	L/L	SS216 LI117	FRANKLIN L FRANKLIN L	3.00	.0	W	0910A-1000A 1010A-1200P	31 75
------	-----	----------------	--------------------------	------	----	---	----------------------------	-------

**AE 605 Vocational Training VI**

Transferable: No

This course is designed for students with disabilities. The purpose of this course is to improve the student's ability to participate in the community, by increasing independence through acquisition of survival vocabulary, structured practice in functional reading utilizing phonics and content recognition, and increased enjoyment in reading for pleasure. Opportunities will be provided for oral reading of high interest-low reading level life experience stories written or revised specifically for adults with limited reading skills.

4022	L/L	BU117	BROWN C	1.50	.0	Th	1210P-0130P	31 75
------	-----	-------	---------	------	----	----	-------------	-------

**AE 613 Independence Training IV**

Transferable: No

This course is designed for students with disabilities. The purpose of this course is to improve the student's ability to build math competencies related to independence in daily living and the work site. The focus of the class is basic computation, consumer awareness, money management, banking and purchasing.

4023	L/L	BU117	BROWN C	1.50	.0	Tu	1210P-0130P	31 75
------	-----	-------	---------	------	----	----	-------------	-------

**AE 636 Adapted Physical Education**

Advisory: Students must be able to document a physical disability.

Transferable: No

An individualized program of adapted physical education activities designed to meet the needs of students who are physically limited or disabled. The course assists in the development and appreciation of physical activity as a regular planned contribution to one's overall well-being. This course is for the non-matriculating student, is not graded and is without college credit.

4024	LAB	GY999	ELLIS D	3.00	.0	DHR	0000-0000	31 75 90
------	-----	-------	---------	------	----	-----	-----------	----------

4025	LAB	LOADCS	CRETIN A	3.00	.0	MW	0930A-1045A	70 31 75
------	-----	--------	----------	------	----	----	-------------	----------

See Footnote: Above class meets Off Campus

4026	LAB	HOLLCC	CRETIN A	3.00	.0	MW	1115A-1230P	68 31 75
------	-----	--------	----------	------	----	----	-------------	----------

See Footnote: Above class meets Off Campus

4027	LAB	LOADCS	MARINGER J	3.00	.0	TuTh	0110P-0215P	70 31 75
------	-----	--------	------------	------	----	------	-------------	----------

See Footnote: Above class meets Off Campus

**Word Processing: See CSIS****WORK EXPERIENCE****CWE 190 Occupational Work Experience**

**Required:** Declared vocational major. Concurrent enrollment in seven or more units (including CWE units, except for summer school. For summer school, enrollment in one other class is required). Minimum 2.00 G.P.A.

Transferable: CSU

Occupational work experience for students who have a job related to their major. A training plan is developed cooperatively between the employer, college and student. (CR/NC grading) 75 hours per semester paid work = 1 unit. 60 hours non-paid (volunteer) work per semester = 1 unit. May be taken for a maximum total of 16 units.

4262	WEX	SC154S	KERR L	5.00	1.0	TBA	0000-0000	16
------	-----	--------	--------	------	-----	-----	-----------	----

See Footnote: Above class meets Off Campus

4263	WEX	SC154S	KERR L	10.00	2.0	TBA	0000-0000	16
------	-----	--------	--------	-------	-----	-----	-----------	----

See Footnote: Above class meets Off Campus

4264	WEX	SC154S	KERR L	15.00	3.0	TBA	0000-0000	16
------	-----	--------	--------	-------	-----	-----	-----------	----

See Footnote: Above class meets Off Campus

4265	WEX	SC154S	KERR L	20.00	4.0	TBA	0000-0000	16
------	-----	--------	--------	-------	-----	-----	-----------	----

See Footnote: Above class meets Off Campus

**CWE 192 General Work Experience Education**

**Required:** Concurrent enrollment in seven or more units (including CWE units, except for summer school. For summer school, enrollment in one other class is required) Minimum 2.00 G.P.A.

Transferable: CSU

General work experience for students who have a job unrelated to their major. General work experience is supervised employment which is intended to assist students in acquiring desirable work habits, attitudes and career awareness. A training plan is developed cooperatively between the employer, college and student. (CR/NC grading) 75 hours per semester paid work = 1 unit. 60 hours non-paid (volunteer) work per semester = 1 unit. May be taken for a maximum of 16 units.

4266	WEX	SC154S	KERR L	5.00	1.0	TBA	0000-0000	16
------	-----	--------	--------	------	-----	-----	-----------	----

See Footnote: Above class meets Off Campus

4267	WEX	SC154S	KERR L	10.00	2.0	TBA	0000-0000	16
------	-----	--------	--------	-------	-----	-----	-----------	----

See Footnote: Above class meets Off Campus

4268	WEX	SC154S	KERR L	15.00	3.0	TBA	0000-0000	16
------	-----	--------	--------	-------	-----	-----	-----------	----

See Footnote: Above class meets Off Campus

**FOOTNOTES**

- Footnote #1 Tutorial help is offered for this class. See your instructor.
- Footnote #2 Make appointment with DSP&S Office.
- Footnote #3 Locational painting sessions followed by functional critiques.
- Footnote #4 Students should consider concurrent enrollment in CGD 110 lab class for 1 unit requiring 3 hours of additional lab per week.
- Footnote #5 Basic hand tools required. Details at the first class meeting.
- Footnote #6 \*\*\*\*\*
- Footnote #7 Orientation required. Schedule available in BU 110.
- Footnote #8 Morgan Hill Community Center/Computer Lab hours (TBA).
- Footnote #9 Gavilan Business/Computer Lab hours in BU 110 for students are: Mon/Wed/Thu & Fri from 9 a.m. - 2 p.m. & Tues from 9 a.m. - 3 p.m. & Tues evening from 6:00 - 9:25 p.m..
- Footnote #10 Hollister Briggs/Computer Lab hours (TBA).
- Footnote #11 Short-term classes meet on specified dates.
- Footnote #12 Recommended for students with verified learning disability.
- Footnote #13 This hybrid lecture/online class will be delivered partially over the internet. See the online syllabus for details. <http://www.gavilan.edu/disted/>.
- Footnote #14 In order to obtain Field Work Credit for the Occupational Work Experience placement, students must enroll in CD30A or 30B.
- Footnote #15 The instructor will be using and supporting a TI-83 Plus graphing calculator in all classroom demonstrations.
- Footnote #16 Mandatory course orientation will be conducted Wednesday, February 22 or Thursday, February 23, 2006 from 12-1 p.m. in SC 154N. Students need to attend one of the two meetings. Please contact Lynda Kerr, CWE Coordinator at (408) 846-4993 for more information.
- Footnote #17 Meets at Anzar High School, 2000 San Juan Hwy., San Juan Bautista.
- Footnote #18 This class has a department exam on Saturday, May 13, 2006 from 9 - 11 a.m. in SS 210. (ENGL 250)
- Footnote #19 Please contact Debbie Roderick at the Tutoring Center in LI 116 or call (408) 848-4838 upon enrolling in this class.

- Footnote #20 This course is pending approval for general education (CSU-GE and IGETC). Please see a counselor for more information.
- Footnote #21 Field Work and Service: May be repeated three times for credit.
- Footnote #22 Independent Study: The Dean must approve the study outline prepared by the student and instructor. May be repeated three times for credit.
- Footnote #23 Students must purchase a uniform, lab coat, shoes and a skin care kit; (approximately \$500). This does not include books and classroom materials.
- Footnote #24 Students must furnish gloves and safety glasses... approximately \$20.
- Footnote #25 Dually listed course. Refer to Gavilan College Catalog.
- Footnote #26 Students will pay approximately \$20 in ball/equipment rental.
- Footnote #27 Students must purchase a cosmetology kit, manikin and uniform (approximately \$500). This does not include books and classroom materials.
- Footnote #28 Meets at Gavilan College Aviation Department, 490 Skylane Drive, Hollister Airport, Hollister.
- Footnote #29 This course is co-taught by two instructors.
- Footnote #30 Class meets reduced contact hours for reduced units.
- Footnote #31 Open entry-open exit.
- Footnote #32 \$12 course material fee. Additional \$3.00 due upon completion for certification card. (AH)
- Footnote #33 Classes meet 1/2 regular hours, receiving .5 unit value.
- Footnote #34 This class is taught in Spanish. (Esta clase sera enseñada en español.)
- Footnote #35 "&" means additional lab hours are required.
- Footnote #36 This class is part of a learning community. You must enroll in both courses.
- Footnote #37 This class meets Fridays, February 24 – April 7, 2006. There is only ONE Saturday meeting (March 11, 2006) that will meet in LI 116.
- Footnote #38 This online class will be delivered entirely over the Internet. After enrolling, start the class by going to <http://www.gavilan.edu/disted/>, click on your class link and email your instructor.
- Footnote #39 This class will meet at the Child Development Center one Friday, March 10, 2006 from 6:00 - 8:50 p.m. and two Saturdays March 11 and 18 from 9:00 a.m. - 4:00 p.m.
- Footnote #40 This class will be taught in English and Spanish for ESL students. (Esta clase se enseña en inglés y español.)
- Footnote #41 Meets at the Veteran's Memorial Bldg., 649 San Benito St., Hollister, room 218.
- Footnote #42 There will be an in-person orientation the first week of classes. Details will be sent to registrants by email.
- Footnote #43 \*\*\*\*\*
- Footnote #44 Equipment will be provided. A \$1.00 user fee will be charged, payable to the instructor.
- Footnote #45 Meets at Hazel Hawkins Hospital, 911 Sunset Drive, Hollister.
- Footnote #46 This HYBRID lecture/online class will be delivered partially over the internet. This course will meet 60% in the classroom and 40% online. Come to the campus for the first day of class. (CMUN 11)
- Footnote #47 Meets at San Benito High School, 1220 Monterey Street, Hollister.
- Footnote #48 This class is part of a learning community. You are encouraged to enroll in a complimentary course with linked curriculum.
- Footnote #49 A facility use fee will be charged. Details at first meeting.
- Footnote #50 Students taking this class will need to complete 10 hours of mentoring.
- Footnote #51 Meets at HOPE Workshop, 2300 Technology Parkway, Hollister.
- Footnote #52 Class meets at 7:30 a.m. in PH101 for first class session.
- Footnote #53 Required meeting for CSIS 46, Sunday Feb. 5, 2006 from 4:00 – 7:50 pm at the Morgan Hill site in room MHG 8.
- Footnote #54 Required meetings for CSIS 48, Saturday Feb. 4, and Saturday Feb. 25, 2006 from 8:30 am – 12:30 pm at the Morgan Hill site in room MHG 8.
- Footnote #55 Required meeting for CSIS 175B and 175C Monday Jan. 30, 2006 from 6:30 - 9:20 PM at the Gilroy Gavilan site in room BU 118. Some Monday evening arranged lab hours will also be required.
- Footnote #56 Meets at Britton School, 80 W. Central Avenue, Morgan Hill.
- Footnote #57 This CD class meets 7 Saturdays, Jan 28, Feb 4, 11, 25, March 4, 11 and 18, 2006 from 9:00 a.m. - 4:30 p.m. at the Morgan Hill Community Center.
- Footnote #58 This CD class meets 7 Saturdays, March 25, April 1, 8, 22 29, 2006 and May 6 and 13 from 8:30 a.m. - 4:00 PM at the Morgan Hill Community Center.
- Footnote #59 Meets at Employment Training Center, (formerly Weibe Manufacturing Bldg.), 1131 San Felipe Rd., Hollister.
- Footnote #60 Course delivery is through Gavilan Channel 18, Morgan Hill MHAT Channel 18 or video tape (\$25 refundable security deposit required.) This telecourse will have three required on-campus meetings, Wednesdays, January 25, March 22 and May 24, 2006. Orientation for the course will be provided at the first class meeting. (Hum 4)
- Footnote #61 \*\*\*\*\*
- Footnote #62 Meets at Gilroy Bowl, 7554 Monterey Street, Gilroy. A facility use fee of \$1.25 per session required.
- Footnote #63 Meets at HOPE Workshop, 8855 Murray Avenue, Gilroy.
- Footnote #64 Meets at Gilroy High School, 750 West Tenth Street, Gilroy.
- Footnote #65 Class will meet on Monday, April 24, 2006 in LS101 for a lecture and to discuss preparations for the field component of the class. Class will meet Friday, April 28th at Big Basin Redwood State Park and camp Friday and Saturday nights. Sunday the class will take a day trip to nearby Castle Rock State Park.
- Footnote #66 Dates to be announced, see instructor.
- Footnote #67 This class meets in the choir room of Gilroy High School.
- Footnote #68 Meets at Hollister Community Center, 300 West Street, Hollister.
- Footnote #69 \*\*\*\*\*
- Footnote #70 Meets at Live Oak Adult Day Care, 651 West Sixth Street, Gilroy.
- Footnote #71 This section of CD 190 is for students working as tutors in elementary school settings.
- Footnote #72 AJ class not recommended for high school students.
- Footnote #73 This class requires a co-requisite of First Year Experience GUID 1 and English 250.
- Footnote #74 May be repeated based on measurable progress as documented in the Student's IEP Plan. (DSPS)
- Footnote #75 Special registration procedures.
- Footnote #76 Please contact the Allied Health Department at (408) 848-4883 for more information.
- Footnote #77 Course will include the viewing of a cadaver.
- Footnote #78 This class requires a co-requisite of First Year Experience GUID 1 and English 260.
- Footnote #79 This class involves both lecture and hands-on computer assisted software. A lab fee of \$60.00 must be paid to the instructor during the first class meeting. Materials included in the lab fee take the place of a textbook. MATH 404, A-C is the equivalent of MATH 400. MATH 404, D-F is the equivalent of MATH 402.
- Footnote #80 Recommended for students participating in the EOP&S program.
- Footnote #81 Recommended for students participating in TRIO program.
- Footnote #82 This class is part of a Puente learning community. You must enroll in both courses.
- Footnote #83 Recommended for students participating in CalWORKs Program.
- Footnote #84 This online course will have two required Friday meetings on campus: Jan.27 and Apr. 28 in HU 102 from 1:00 to 3:30 pm.
- Footnote #85 This class requires a co-requisite of First Year Experience English 250 and English 260.
- Footnote #86 There will be no Friday class on January 6, 2006.
- Footnote #87 See information regarding open lab in box on page 87 of the Gavilan Class Schedule.
- Footnote #88 This class is designed for students participating in the CalWORKs program.
- Footnote #89 \$12.00 fee will be charged for career assessment materials.
- Footnote #90 Recommended for students with verified physical limitations.
- Footnote #91 \*\*\*\*\*
- Footnote #92 Health and fingerprint clearance required prior to clinical placement. Uniform, shoes, watch, and stethoscope required.
- Footnote #93 \$100.00 course materials fee, payable at registration.
- Footnote #94 Clinical in Morgan Hill or Hollister, as assigned.
- Footnote #95 \$20 materials fee. Payable at registration.
- Footnote #96 ROP class. Either college credit or ROP certificate.
- Footnote #97 Mandatory Puente orientation will be conducted on Wednesday, August 17, 2005, from 9 am - 1 pm in SS 210. (Fall only)
- Footnote #98 \$5 course materials fee. Details at first class meeting.
- Footnote #99 Computer lab work can be done both in lab and off-site
- \*\*\*\*\* indicates this footnote number not being used this term.

## Preparing for

- **an Associate's Degree** (60 units)
- **a Certificate of Completion** (18 units or more)
- **a Certificate of Achievement** (17 units or less)
- **transfer** (learn about transfer patterns and major preparation)
- **the working world**

**Make an appointment with a counselor to**

**develop your Education Plan.**

***Reach your goal as soon as possible!***



## One day Counseling Services

available in Hollister the second  
Thursday of each month  
(excluding summer)

Call (831) 636-3783 to  
schedule an appointment.  
See page 10.

## Hollister Briggs Building

(San Benito County)

Briggs Building  
365 Fourth St.  
Hollister, CA 95023  
(831) 636-3783

Site Office Hours: See page 5

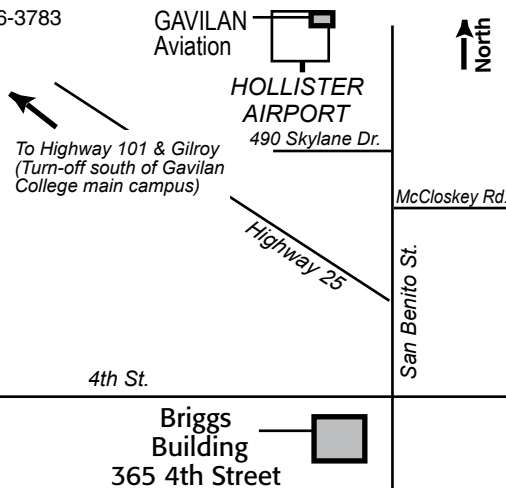

# 4 GE Classes 4 Mornings a Week 4 A Full Load 4 Spring

*Take 12 units  
of transferable  
General Education  
classes at  
Hollister*

**SECT COURSE DESCRIPTION UNITS TIME ROOM**

**Monday/Wednesday**

4316	ENGL 1C	CRITIC REASON/WRITE	3.0	900A-1015A	HOL1
4407	GEOG 1	PHYSICAL GEOG L/L	3.0	900A-1125A	HOL4
4342	ENGL 250	PRACTICAL WRITING Lab:	3.0	1030A-1145A 1200P-1250P	HOL1 HOL1
4341	ENGL 250	PRACTICAL WRITING Lab:	3.0	1030A-1145A 1200P-1250P	HOL1 HOL1

**Tuesday/Thursday**

4682	POLS 1	INTRO AMERICAN GOVERNMENT	3.0	900A-1015A	HOL6
4713	SOC 21	MARRIAGE & FAMILY	3.0	900A-1015A	HOL2
4294	ENGL 1A	COMPOSITION	3.0	1030A-1145A	HOL1

**Mon/Tues/Wed/Thurs**

4716	SPAN 1A	ELEMENTARY SPANISH	5.0	900A-1005A	HOL5
4719	SPAN 1B	ELEMENTARY SPANISH	5.0	1015A-1120A	HOL6
4550	MATH 205	ELEM ALGEBRA	5.0	1030A-1145A	HOL5
4561	MATH 233	INTERMED ALGEBRA	5.0	1030A-1135A	HOL2

We are pleased to provide the following services for your convenience at the Hollister Briggs Building satellite site:

**Admissions** Accept applications for admission  
Sell catalogs and distribute class schedules

**Registration and Records** Class registration  
Add/drops  
Assessment test results  
Unofficial grade print-outs  
Dispense forms: Transcript Requests,  
Repeated Course Requests, Prerequisite  
Challenge Forms, etc.

**Orientations** (online)

**Placement Assessment** on site (check website for times and locations)

**Counseling** Academic and educational planning (One day per month, by appointment) See page 10 for dates/times.

**Financial Aid** Assistance with BOG Fee Waiver forms  
Assistance with financial aid information

**Book and Library Services** Order textbooks on-line at efollet.com  
Purchase scantrons and bluebooks  
Borrow library books online and pick them up at satellite sites www.gavilan.edu/library

**Career/Transfer** College catalog library, EUREKA online

**Computer Access**

Services for veterans and international students available at the main campus. All other services, including EOP&S, DRC, CalWORKs, CARE, MESA, TRIO and the Tutoring Center available at the Gilroy main campus. Call 408-848-4800. Check catalog or website for complete listings - www.gavilan.edu



Gavilan College offers courses that meet in Morgan Hill and Hollister, on the weekend and start late in the semester. See course listings starting on page 40 (spring) and page 104 (summer) and consult a counselor for guidance. Students may register at any of our three sites or by telephone.

SECT	COURSE	DESCRIPTION	UNITS	BEGIN	END	DAY	TIMES	ROOM
6004	ACCT 105	PAYROLL ACCOUNTING	2.0	01/23	05/22	Th	630P-820P	HOL6
4052	AH 740	TAI CHI ARTHRITIS	0.0	01/12	05/11	Th	1100A-1200P	HOLCC
4067	AMT 101	GEN AIRCRAFT TECH	7.5	01/17	05/26	DAILY	800A-1030A	AV102 *
4068	AMT 111	AIRFRAME STRUCTURES	13.5	01/23	05/26	DAILY	1030A-330P	AV102 *
4069	AMT 121	POWERPLT SYS/TECH	14.0	01/17	05/26	TuWThF	830A-300P	AV102 *
6012	ART 1B	ART HISTORY	3.0	01/25	05/24	W	630P-920P	HOL1
6017	ART 25A	ART METHODS	3.0	01/23	05/26	SAT	900A-1250P	HOL1
6018	ART 25B	CONCEPT ART METHODS	3.0	01/23	05/26	SAT	900A-1250P	HOL1
6031	CD 3	CHILD GROWTH/DEV	3.0	01/23	05/22	M	600P-850P	HOL2
6033	CD 8B	TEACH READ/WRIT	3.0	01/24	05/23	Tu	600P-850P	HOL1
6039	CD 25A	ART METHODS	3.0	01/28	05/20	SAT	900A-1250P	HOL1
6040	CD 25B	CONCEPT ART METHODS	3.0	01/28	05/20	SAT	900A-1250P	HOL1
6047	CMUN 10	SMALL GROUP CMUN	3.0	01/23	05/22	W	630P-920P	HOL6
6052	CSIS 1	COMPUTER LITERACY	2.0	01/24	03/21	Tu	600P-950P	HOL3
4213	CSIS 1	COMPUTER LITERACY	2.0	01/30	03/15	M W	930A-1220P	HOL3
6063	CSIS 121	SPREADSHEET-MS EXCL	2.0	01/26	03/23	Th	600P-950P	HOL3
6065	CSIS 122	COMPUTER KEYBOARD	1.0	01/23	05/22	M	600P-850P	HOL3
6066	CSIS 122	COMPUTER KEYBOARD	0.5	01/23	05/22	M	600P-850P	HOL3
4238	CSIS 122	COMPUTER KEYBOARD	0.5	01/23	05/26	M W	1010A-1200P	HOL3
4239	CSIS 122	COMPUTER KEYBOARD	1.0	02/01	05/03	M W	1010A-1200P	HOL3
6069	CSIS 124	WINDOWS FUNDAMENTAL	1.0	02/08	03/08	W	600P-950P	HOL3
4241	CSIS 124	WINDOWS FUNDAMENTAL	1.0	03/20	04/03	M W	910A-100P	HOL3
4246	CSIS 126	WORD PROCESS-MS WRD	2.0	04/05	05/10	M W	910A-100P	HOL3
6070	CSIS 126	WORD PROCESS-MS WRD	2.0	03/15	05/17	W	600P-950P	HOL3
6081	ENGL 1A	COMPOSITION	3.0	01/24	05/23	Tu	630P-920P	HOL2
4294	ENGL 1A	COMPOSITION	3.0	01/24	05/25	Tu Th	1030A-1145A	HOL1
4316	ENGL 1C	CRITIC REASON/WRITE	3.0	01/23	05/24	M W	900A-1015A	HOL1
6089	ENGL 250	PRACTICAL WRITING	3.0	01/26	05/25	Th	530P-920P	HOL1
4342	ENGL 250	PRACTICAL WRITING	3.0	01/23	05/24	M W	1030A-1145A	HOL1
					Lab:	W	1200P-1250P	HOL1
4341	ENGL 250	PRACTICAL WRITING	3.0	01/23	05/24	M W	1030A-1145A	HOL1
					Lab:	M	1200P-1250P	HOL1
4383	ENGL 750	CREATIVE WRITING OA	0.0	01/12	05/11	Th	100P-200P	HOLCC
6094	ESL 501A	SURVIVAL ESL I A	3.0	01/23	05/26	M W F	615P-745P	HOL5
6097	ESL 502A	SURVIVAL ESL II A	3.0	01/23	05/26	M W F	800P-925P	HOL5
6098	ESL 503A	SURVIVAL ESL III A	3.0	01/23	05/26	M W F	615P-745P	HOL4
6100	ESL 503B	SURVIVAL ESL III B	3.0	01/23	05/26	M W F	800P-925P	HOL4
4407	GEOG 1	PHYSICAL GEOG L/L	3.0	01/23	05/26	M W	900A-1125A	HOL4
6105	HIST 2	U.S. HISTORY	3.0	01/23	05/26	W	630P-920P	HOL2
4457	HUM 767	FILM CLASSICS	0.0	01/10	04/11	Tu	100P-400P	HOLCC
4539	LIB 730	INTERNET LITERACY	0.0	03/07	04/13	Tu Th	100P-230P	HOL3
4538	LIB 730	INTERNET LITERACY	0.0	01/09	02/15	M W	100P-230P	HOL3
6117	MATH 5	INTRO STATISTICS	3.0	01/23	05/26	Th	530P-920P	HOL2
4756	MUS 9A	GIUITAR	1.0	01/23	05/22	M	100P-350P	HOL2
4550	MATH 205	ELEM ALGEBRA	5.0	01/23	05/25	MTuWTh	1030A-1145A	HOL5
4561	MATH 233	INTERMED ALGEBRA	5.0	01/23	05/25	MTuWTh	1030A-1135A	HOL2
6125	MATH 233	INTERMED ALGEBRA	5.0	01/24	05/25	Tu Th	600P-835P	HOL4
6153	PE 62	YOGA	1.0	01/24	05/25	Tu Th	500P-615P	VET218 **
4669	PE 716	MUSIC MOVE & HEALTH	0.0	01/10	05/09	Tu	1000A-1200P	HOLCC
4682	POLS 1	INTRO AMERICAN GOVERNMENT	3.0	01/24	05/25	Tu Th	900A-1015A	HOL6
6156	PSYC 1A	INTRO TO PSYCHOLOGY	3.0	01/23	05/26	Tu	600P-850P	HOL5
6158	PSYC 3	CHILD GROWTH/DEV	3.0	01/23	05/22	M	600P-850P	HOL2
6161	SOC 1A	INTRO TO SOCIOLOGY	3.0	01/23	05/22	M	630P-920P	HOL1
6163	SOC 21	MARRIAGE & FAMILY	3.0	01/26	05/25	Th	630P-920P	HOL5
4713	SOC 21	MARRIAGE & FAMILY	3.0	01/24	05/25	Tu Th	900A-1015A	HOL2
4716	SPAN 1A	ELEMENTARY SPANISH	5.0	01/23	05/25	MTuWTh	900A-1005A	HOL5
4719	SPAN 1B	ELEMENTARY SPANISH	5.0	01/23	05/25	MTuWTh	1015A-1120A	HOL6
6165	SPAN 8A	CONVER SPANISH	3.0	01/23	05/22	M	630P-920P	HOL6

\* Meets at Gavilan College Aviation Department, 490 Skylane Drive, Hollister Airport, Hollister. Aviation classes begin January 17, 2006.

\*\* Meets at Veterans' Memorial Bldg., San Benito St., Hollister, room 218.



Gavilan College offers courses that meet in Morgan Hill and Hollister, on the weekend and start late in the semester. See course listings starting on page 104 (summer) and page 42 (spring) and consult a counselor for guidance. Students may register at any of our three sites or by telephone.

<u>SECT</u>	<u>COURSE</u>	<u>DESCRIPTION</u>	<u>UNITS</u>	<u>BEGIN</u>	<u>END</u>	<u>DAY</u>	<u>TIMES</u>	<u>ROOM</u>
6003	ACCT 103	GEN OFFICE ACCT	2.0	01/23	05/22	M	630P-920P	MHG4
6005	ACCT 120	COMPUTERIZED ACCTNG	2.0	01/26	05/25	Th	630P-920P	MHG5
4050	AH 740	TAI CHI/ARTHRIT/REL ILLNESS	0.0	01/12	05/11	TH	0900A-1000A	HVME1 *
6008	AJ 18	CMUN/HUMAN RELATION	3.0	01/23	05/26	M	630P-920P	MHG3
6009	AJ 19	INTRO/INVESTIGATION	3.0	01/25	05/24	W	630P-920P	MHG13
4076	ANTH 3	INTRO CULTURAL ANTH	3.0	01/23	05/24	M W	1200P-115P	MHG13
6011	ART 1A	ART HISTORY	3.0	01/23	05/26	W	630P-920P	MHG11
6019	ART 75	PHOTOSHOP I	3.0	01/24	05/23	Tu	630P-920P	MHG5
6023	ASTR 1	INTRO GEN ASTRONOMY	3.0	01/23	05/26	Tu	645P-935P	MHG3
4149	BOT 180	MEDICAL TERM/OFFICE	3.0	01/24	05/23	Tu	310P-600P	MHG10
6029	CD 1	PRIN/PHIL EC EDUC	3.0	01/28	05/13	SAT	830A-300P	MHG3
4158	CD 3	CHILD GROWTH/DEV	3.0	01/23	05/24	M W	1030A-1145A	MHG4
6034	CD 10	THE EXCEPT CHILD	3.0	01/26	05/25	Th	600P-850P	MHG10
6035	CD 11A	ADMIN/PROGRAM CHILD	3.0	03/25	05/13	SAT	800A-400P	MHG4
6036	CD 12	COMPUTER ED TEACHER	3.0	01/28	03/18	SAT	900A-430P	MHG8
6037	CD 13	INFANT/TODDLER CARE	3.0	01/24	05/23	Tu	600P-850P	MHG11
4162	CD 19	INTRO CAREERS/CHLDN	2.0	01/23	05/24	M W	1200P-1250P	MHG4
6043	CD 30B	TEACH PRAC&TECH. II	3.0	01/25	05/24	W	600P-850P	MHG4
6044	CD 98	SPECIAL TOPICS	1.0	01/03	01/19	Tu Th	630P-920P	MHG4
4188	CMUN 1A	INTRO PUBLIC SPEAK	3.0	01/24	05/25	Tu Th	900A-1015A	MHG12
6048	CMUN 10	SMALL GROUP CMUN	3.0	01/23	05/26	W	630P-920P	MHG12
4196	CMUN 10	SMALL GROUP CMUN	3.0	01/24	05/25	Tu Th	1030A-1145A	MHG11
6050	CMUN 129	PRESENTATN GRAPHICS	1.0	02/04	03/11	SAT	830A-1220P	MHG5
4219	CSIS 8	INTRO TO INTERNET	1.0	05/04	05/18	Tu Th	910A-100P	MHG8
6056	CSIS 9	COMPUTER ED TEACHER	3.0	01/28	03/18	SAT	900A-430P	MHG8
4221	CSIS 23	INDEPENDENT STUDY	1.0	01/23	05/26	F	400P-800P	MHG8
6060	CSIS 61	INTRO TO GIS	4.0	01/23	05/26	W	600P-950P	MHG5
6061	CSIS 75	PHOTOSHOP I	3.0	01/24	05/23	Tu	630P-920P	MHG5
6062	CSIS 120	COMPUTER ACCOUNTING	2.0	01/26	05/25	Th	630P-920P	MHG5
6064	CSIS 121	SPREADSHEET-MS EXCL	2.0	03/18	05/20	SAT	830A-1220P	MHG5
4240	CSIS 122	COMPUTER KEYBOARD	1.0	02/28	05/18	Tu Th	1010A-1200P	MHG8
4237	CSIS 122	COMPUTER KEYBOARD	0.5	02/28	05/18	Tu Th	1010A-1200P	MHG8
4242	CSIS 124	WINDOWS FUNDAMENTAL	1.0	03/09	03/23	Tu Th	910A-100P	MHG8
4244	CSIS 126	WORD PROCESS-MS WRD	2.0	03/28	05/02	Tu Th	910A-100P	MHG8
6071	CSIS 128	DATABASE-MS ACCESS	2.0	02/01	03/29	W	600P-950P	MHG8
6072	CSIS 129	PRESENTATN GRAPHICS	1.0	02/04	03/11	SAT	830A-1220P	MHG5
6077	DM 75	PHOTOSHOP I	3.0	01/24	05/23	Tu	630P-920P	MHG5
4295	ENGL 1A	COMPOSITION	3.0	01/24	05/25	Tu Th	1030A-1145A	MHG4
6082	ENGL 1A	COMPOSITION	3.0	01/26	05/25	Th	630P-920P	MHG3
4307	ENGL 1B	COMPOSITION & LIT	3.0	01/23	05/24	M W	900A-1015A	MHG12
4317	ENGL 1C	CRITIC REASON/WRITE	3.0	01/23	05/24	M W	1030A-1145A	MHG12
6102	GBUS 80	BUSINESS LAW	3.0	01/26	05/25	Th	600P-850P	MHG4
4409	GEOG 2	CULTURAL GEOGRAPHY	3.0	01/23	05/24	M W	900A-1015A	MHG4
4447	HIST 2	U.S. HISTORY	3.0	01/23	05/24	M W	900A-1015A	MHG10
4451	HIST 7B	HIST WESTERN CIVIL	3.0	01/23	05/24	M W	1030A-1145A	MHG10
4537	LIB 730	INTERNET LITERACY	0.0	01/10	02/16	Tu Th	1130A-100P	MHG5
4536	LIB 730	INTERNET LITERACY	0.0	03/06	04/12	M W	1130A-100P	MHG5
4540	LIB 731	FIND BOOK TREAS IN LIT/ OA	0.0	01/11	02/15	W	0100P-0400P	HVME1 *
6118	MATH 5	INTRO STATISTICS	3.0	01/23	05/26	Tu	530P-630P	MHG5
	MATH 5	INTRO STATISTICS	3.0	01/23	05/26	Tu	630P-920P	MHG4
4551	MATH 205	ELEM ALGEBRA	5.0	01/23	05/25	MTuWTh	900A-1005A	MHG13
6122	MATH 205	ELEM ALGEBRA	5.0	01/24	05/25	Tu Th	645P-910P	MHG13
4559	MATH 233	INTERMED ALGEBRA	5.0	01/23	05/25	MTuWTh	900A-1005A	MHG11
4608	MUS 762	JOY LISTEN TO MUSIC	0.0	01/13	04/28	F	100P-300P	MHG11
6151	PE 62	YOGA	1.0	01/23	05/24	M W	500P-615P	MHG10/11
4670	PE 716	MUSIC MOVEMENT & HEALTH	0.0	01/13	05/12	F	1000A-1200P	HVME1 *
4694	PSYC 1A	INTRO TO PSYCHOLOGY	3.0	01/24	05/25	Tu Th	1030A-1145A	MHG3
4699	PSYC 3	CHILD GROWTH/DEV	3.0	01/23	05/24	M W	1030A-1145A	MHG4
4709	SOC 1A	INTRO TO SOCIOLOGY	3.0	01/24	05/25	Tu Th	900A-1015A	MHG3
6164	SPAN 1A	ELEMENTARY SPANISH	5.0	01/23	05/24	M W	530P-920P	MHG13
4750	THEA 764	THEATRE EXPERIENCE	0.0	01/13	03/31	F	100P-400P	MHG10

\* Meets at Hacienda Valley Mobile Estates, 275 Burnett Ave., Morgan Hill

# 4 GE Classes 4 Mornings a Week 4 A Full Load 4 Spring

*Take 12 units  
of transferable  
General Education  
classes at  
Morgan Hill*

<u>SECT</u>	<u>COURSE</u>	<u>DESCRIPTION</u>	<u>UNITS</u>	<u>TIME</u>	<u>ROOM</u>
<b><u>Monday/Wednesday</u></b>					
4307	ENGL 1B	COMPOSITION & LIT	3.0	900A-1015A	MHG12
4409	GEOG 2	CULTURAL GEOGRAPHY	3.0	900A-1015A	MHG4
4447	HIST 2	U.S. HISTORY	3.0	900A-1015A	MHG10
4158	CD 3	CHILD GROWTH/DEV	3.0	1030A-1145A	MHG4
4317	ENGL 1C	CRITIC REASON/WRITE	3.0	1030A-1145A	MHG12
4451	HIST 7B	HIST WESTERN CIVIL	3.0	1030A-1145A	MHG10
4699	PSYC 3	CHILD GROWTH/DEV	3.0	1030A-1145A	MHG4
4162	CD 19	INTRO CAREERS/CHLDN	2.0	1200P-1250P	MHG4
4076	ANTH 3	INTRO CULTURAL ANTH	3.0	1200P-115P	MHG13
<b><u>MTuWTh</u></b>					
4551	MATH 205	ELEM ALGEBRA	5.0	900A-1005A	MHG13
4559	MATH 233	INTERMED ALGEBRA	5.0	900A-1005A	MHG11
<b><u>Tuesday/Thursday</u></b>					
4188	CMUN 1A	INTRO PUBLIC SPEAK	3.0	900A-1015A	MHG12
4709	SOC 1A	INTRO TO SOCIOLOGY	3.0	900A-1015A	MHG3
4196	CMUN 10	SMALL GROUP CMUN	3.0	1030A-1145A	MHG11
4295	ENGL 1A	COMPOSITION	3.0	1030A-1145A	MHG4
4694	PSYC 1A	INTRO TO PSYCHOLOGY	3.0	1030A-1145A	MHG3

## Two day Counseling Services

available in Morgan Hill  
Appointment or drop-in

**Dates: the 1st and 3rd  
Thursdays of each month**  
(excluding summer)

(See page 10 for dates/times)

Call (408) 782-2873 to schedule  
an appointment.

## Morgan Hill Community and Cultural Center

17060 Monterey Rd.  
Morgan Hill, CA 95037  
(408) 782-2873

Site Office Hours - See page 5

Highway 101

North  
←

Church St.

E Dunne Ave.

Monterey Rd.

We are pleased to provide the following services for your convenience at the Morgan Hill Community Center satellite site:

**Admissions** Accept applications for admission  
Sell catalogs and distribute class schedules

**Registration and Records** Class registration  
Add/drops  
Assessment test results  
Unofficial grade print-outs  
Dispense forms: Transcript Requests, Repeated Course Requests, Prerequisite Challenge Forms, etc.

**Orientations** (online)

**Placement Assessment** on site (check website for times and locations)

**Counseling** Academic and educational planning (Two days per month, by appointment or drop-in. See page 10 for dates/times)

**Financial Aid** Assistance with BOG Fee Waiver forms  
Assistance with financial aid information

**Book and Library Services** Order textbooks on-line at efollet.com  
Purchase scantrons and bluebooks  
Borrow library books online and pick them up at satellite sites [www.gavilan.edu/library](http://www.gavilan.edu/library)

**Career/Transfer** College catalog library, EUREKA online

**Computer Access**

Services for veterans and international students available at the main campus. All other services, including EOP&S, DRC, CalWORKS, CARE, MESA, TRIO and the Tutoring Center available at the Gilroy main campus. Call 408-848-4800. Check catalog or website for complete listings - [www.gavilan.edu](http://www.gavilan.edu)



## Weekend Courses

The following courses are offered on weekend days at the Gavilan sites in Morgan Hill, Hollister and on the main campus. Students may register at any site, by telephone or in person. Spring courses are described beginning on page 42.

SECT COURSE	DESCRIPTION	UNITS	BEGIN	DAY	TIMES	ROOM	SECT COURSE	DESCRIPTION	UNITS	BEGIN	DAY	TIMES	ROOM
6006	AH 32 BASIC CARD/LIFE SUP	1.0	2/11-2/12	SUN	800A-500P	HOB114	6039	CD 25A ART METHODS	3.0	1/28-5/20	SAT	900A-1250P	HOL1
6007	AH 32 BASIC CARD/LIFE SUP	1.0	3/05-3/05	SAT	800A-500P	HOB114	6040	CD 25B CONCEPT ART METHODS	3.0	1/28-5/20	SAT	900A-1250P	HOL1
6007	AH 32 BASIC CARD/LIFE SUP	1.0	3/05-3/05	SUN	800A-500P	HOB114	6042	CD 28C ADMIN CHLD CARE HOM	1.0	3/10-3/18	F	600P-850P	CD127
6006	AH 32 BASIC CARD/LIFE SUP	1.0	2/11-2/12	SAT	800A-500P	HOB114	6042	CD 28C ADMIN CHLD CARE HOM	1.0	3/10-3/18	SAT	900A-400P	CD127
6017	ART 25A ART METHODS	3.0	1/23-5/26	SAT	900A-1250P	HOL1	6050	CMUN 129 PRESENTATN GRAPHICS	1.0	2/04-3/11	SAT	830A-1220P	MHG5
6018	ART 25B CONCEPT ART METHODS	3.0	1/23-5/26	SAT	900A-1250P	HOL1	6056	CSIS 9 COMPUTER ED TEACHER	3.0	1/28-3/18	SAT	900A-430P	MHG8
6021	ART 98 SPECIAL TOPICS	1.0	1/03-1/21	F	600P-900P	AR101	4221	CSIS 23 INDEPENDENT STUDY	1.0	1/23-5/26	F	400P-800P	MHG8
				SAT	1000A-100P	AR101	6064	CSIS 121 SPREADSHEET-MS EXCL	2.0	3/18-5/20	SAT	830A-1220P	MHG5
6026	BIO 21 FIELD ECOLOGY	1.0	4/24-4/30	M	500P-600P	LS101	6072	CSIS 129 PRESENTATN GRAPHICS	1.0	2/04-3/11	SAT	830A-1220P	MHG5
				F	500P-800P		6079	ENGL 1A COMPOSITION	3.0	1/28-5/20	SAT	910A-1200P	HU102
				SAT	800A-500P		4418	GUID 28 TUTORING TECHNIQUE	1.0	2/24-4/07	SAT	930A-125P	L116
				SUN	800A-300P		6113	LIB 730 INTERNET LITERACY	0.0	1/14-2/18	SAT	100P-300P	SV002
6029	CD 1 PRIN/PHIL EC EDUC	3.0	1/28-5/13	SAT	830A-300P	MHG3	6114	LIB 730 INTERNET LITERACY	0.0	3/11-4/08	SAT	100P-300P	SV002
6035	CD 11A ADMIN/PROGRAM CHILD	3.0	3/25-5/13	SAT	800A-400P	MHG4	6148	PE 17 GOLF 0.5	3/18-5/20	SAT	900A-1130A	GY200C	
6036	CD 12 COMPUTER ED TEACHER	3.0	1/28-3/18	SAT	900A-430P	MHG8							

## Late Afternoon and Evening Courses

Main Campus, Gilroy							Morgan Hill				Hollister				
SECT COURSE	DAY	TIME	SECT COURSE	DAY	TIME	SECT COURSE	DAY	TIME	SECT COURSE	DAY	TIME	SECT COURSE	DAY	TIME	
6001	ACCT 20	W	600P-950P	6054	CSIS 2L	T	600P-950P	6140	MUS 14B	W	700P-950P	6003	ACCT 103	M	630P-920P
6002	ACCT 21	T	600P-950P	6059	CSIS 45	M	600P-950P	6141	MUS 14C	W	700P-950P	6005	ACCT 120	T	630P-920P
4032	AH 11	T	410P-700P	6055	CSIS 5	M	600P-950P	6142	MUS 14D	W	700P-950P	6008	AJ 18	M	630P-920P
4029	AH 3	T	410P-700P	4281	DM 108	M	330P-520P	6144	MUS 23	M	600P-850P	6009	AJ 19	W	630P-920P
4060	AJ 14	W	300P-550P	6078	ECON 1	W	600P-850P	6145	MUS 26	W	700P-950P	6011	ART 1A	W	630P-920P
6010	AJ 176	T	630P-920P	4301	ENGL 1A	MW	400P-515P	6502	MUS 28	W	600P-850P	6019	ART 75	T	630P-920P
4117	ART 108	M	330P-520P	6080	ENGL 1A	M	630P-920P	6129	MUS 4A	M	600P-950P	6023	ASTR 1	T	645P-935P
6013	ART 10A	TT	630P-855P	4312	ENGL 1B	TT	400P-515P	6130	MUS 4B	M	630P-920P	4149	BOT 180	T	310P-600P
6014	ART 10B	TT	630P-920P	6083	ENGL 1B	W	630P-920P	6131	MUS 5A	M	645P-935P	6034	CD 10	T	600P-850P
6021	ART 98	F	600P-900P	6084	ENGL 1C	T	630P-920P	6132	MUS 5B	M	645P-935P	6037	CD 13	T	600P-850P
6022	ASTR 1	W	630P-920P	4351	ENGL 250	M	300P-350P	6133	MUS 5C	M	645P-935P	6043	CD 30B	W	600P-850P
4127	ATH 35	DAILY	400P-600P	4352	ENGL 250	W	300P-350P	6134	MUS 5D	M	645P-935P	6044	CD 98	TT	630P-920P
4130	ATH 45	DAILY	300P-500P	6090	ENGL 250	MW	700P-850P	6147	MUS 98	W	700P-950P	6048	CMUN 10	W	630P-920P
6024	BIO 10	TT	630P-845P	4351	ENGL 250	MW	400P-515P	6146	MUS 98	T	700P-950P	6062	CSIS 120	T	630P-920P
4137	BIO 10	M	345P-545P	4352	ENGL 250	MW	400P-515P	6135	MUS 9A	M	600P-850P	6071	CSIS 128	W	600P-950P
4139	BIO 10	W	345P-535P	6091	ENGL 260	MW	530P-645P	6136	MUS 9B	M	700P-950P	4221	CSIS 23	F	400P-800P
4141	BIO 11	T	410P-700P	6085	ENGL 2C	T	630P-920P	6149	PE 39	M	630P-920P	6060	CSIS 61	W	600P-950P
6025	BIO 15	MW	600P-930P	6092	ENGL 420	TT	530P-645P	4644	PE 46	MTWT	310P-350P	6061	CSIS 75	T	630P-920P
6026	BIO 21	M-Sun	500P-800P	6093	ENGL 440	TT	700P-850P	4645	PE 46	MTWT	310P-350P	6077	DM 75	T	630P-920P
4134	BIO 9	T	410P-700P	6086	ENGL 9A	W	530P-820P	6150	PE 61	TT	500P-615P	6082	ENGL 1A	T	630P-920P
6027	BOT 181	M	600P-850P	6087	ENGL 9B	W	530P-820P	6153	PE 62	TT	500P-615P	6102	GBUS 80	T	600P-850P
6028	BOT 182	T	600P-850P	6088	ENGL 9C	W	530P-820P	6154	PHIL 2	T	630P-920P	6122	MATH 205	TT	645P-910P
6038	CD 17	TT	600P-850P	6095	ESL 501A	MW	615P-830P	4676	PHIL 4	TT	400P-515P	6118	MATH 5	T	630P-920P
6030	CD 2	T	630P-920P	6096	ESL 502A	TT	615P-830P	6155	PSYC 1A	M	600P-850P	6118	MATH 5	T	530P-630P
6041	CD 28A	M	630P-920P	6099	ESL 503A	MW	615P-830P	6157	PSYC 2	T	630P-920P	6151	PE 62	MW	500P-615P
6042	CD 28C	F	600P-850P	6103	GBUS 80	M	630P-920P	6159	RE 160	T	630P-920P	6164	SPAN 1A	MW	530P-920P
6032	CD 4	M	600P-850P	6104	HIST 1	T	630P-920P	6160	RE 162	T	630P-920P				
6045	CHEM 30A	TT	600P-850P	6106	HUM 4	W	700P-950P	6162	SOC 4	T	630P-920P				
6049	CMUN 11	M	630P-920P	6120	MATH 14	M	600P-850P	6170	SPAN 23	T	630P-920P				
6051	CMUN 129	W	600P-950P	6115	MATH 1A	TT	630P-820P	6166	SPAN 8A	T	630P-920P				
6046	CMUN 1A	T	630P-920P	6116	MATH 1C	MW	630P-820P	6167	SPAN 8B	M	630P-920P				
6053	CSIS 1	W	600P-950P	6121	MATH 205	MW	630P-850P	6168	SPAN 8C	T	630P-920P				
4232	CSIS 108	M	330P-520P	6124	MATH 205B	TT	630P-820P	6169	SPAN 8D	T	630P-920P				
6068	CSIS 122	T	600P-850P	6126	MATH 233	MW	630P-855P	6171	THEA 13A	MTWT	630P-920P				
6067	CSIS 122	T	600P-850P	6127	MATH 400	MW	600P-750P	6171	THEA 13A	MTWT	630P-920P				
6073	CSIS 129	W	600P-950P	6128	MATH 402	TT	600P-750P	6172	THEA 13B	MTWT	630P-920P				
6057	CSIS 18	M	600P-850P	6119	MATH 8A	TT	630P-820P	6172	THEA 13B	MTWT	630P-920P				
6075	CSIS 181	T	600P-950P	6137	MUS 12	T	730P-945P	6173	THEA 13C	MTWT	630P-920P				
6076	CSIS 182	T	600P-950P	6138	MUS 13	T	730P-945P	6174	THEA 13D	MTWT	630P-920P				
6058	CSIS 18L	M	900P-950P	6139	MUS 14A	W	700P-950P								



# Late Start - Short Term Courses

The following courses are offered at Gavilan's sites in Morgan Hill, Hollister and on the main campus in Gilroy. Students may register at any location until the last working day before the course begins.

Spring courses are described beginning on page 42.

Also, check out Gavilan's Winter Intersession classes (page 39-41).

## Online

SECT	COURSE	CLASS	UNITS	DATES
4041	AH 140	INFO COMP/HEALTH	1.0	3/06-4/13
4218	CSIS 6	WEBPAGE AUTHORING I	2.0	3/06-5/08
4228	CSIS 84	JAVASCRIPT PROGRAM	2.0	3/06-5/19
4270	DM 6	WEBPAGE AUTHORING I	2.0	3/06-5/08
4416	GUID 1	SELF ASSESSMENT	2.0	3/06-5/05
4532	LIB 140	INTERNET/HLTH PROF	1.0	3/06-4/13
4531	LIB 6	WEBPAGE AUTHORING I	2.0	3/06-5/08
4754	PSCI 2	INTRO METEOROLOGY	3.0	2/06-5/26
4700	PSYC 5	SELF ASSESSMENT	2.0	3/06-5/05
4727	THEA 3	EL TEATRO CAMPESINO	3.0	3/06-5/26

## Main Campus, Gilroy

SECT	COURSE	CLASS	UNITS	DATES	DAYS	TIMES	ROOM
4249	CSIS 132	INTERMEDIATE WORD	2.0	2/08-4/26	W	1100A-200P	BU111
6006	AH 32	BASIC CARD/LIFE SUP	1.0	2/11-2/12	SAT	800A-500P	HOB114
6006	AH 32	BASIC CARD/LIFE SUP	1.0	2/11-2/12	SUN	800A-500P	HOB114
6041	CD 28A	CHILD DEV AND GUID	1.0	2/13-4/10	M	630P-920P	BU118
4398	ESL 546	INTRO COMPUTERS/ESL	1.0	2/13-4/12	M W	1210P-100P	BU119
6054	CSIS 2L	COMPUTRS/BUSNS LAB	1.0	2/14-5/16	Tu	600P-950P	BU110
4418	GUID 28	TUTORING TECHNIQUE	1.0	2/24-4/07	SAT	930A-125P	LI116
4418	GUID 28	TUTORING TECHNIQUE	1.0	2/24-4/07	F	110P-245P	SS111
6007	AH 32	BASIC CARD/LIFE SUP	1.0	3/05-3/05	SAT	800A-500P	HOB114
6007	AH 32	BASIC CARD/LIFE SUP	1.0	3/05-3/05	SUN	800A-500P	HOB114
4535	LIB 730	INTERNET LITERACY	0.0	3/07-4/13	Tu Th	900A-1030A	SV002
4114	ART 85	WEB DESIGN I: DREAM	2.0	3/10-5/19	F	900A-1250P	BU111
4229	CSIS 85	WEB DESIGN I: DREAM	2.0	3/10-5/19	F	900A-1250P	BU111
4278	DM 85	WEB DESIGN I: DREAM	2.0	3/10-5/19	F	900A-1250P	BU111
6042	CD 28C	ADMIN CHLD CARE HOM	1.0	3/10-3/18	F	600P-850P	CD127
6042	CD 28C	ADMIN CHLD CARE HOM	1.0	3/10-3/18	SAT	900A-400P	CD127
6114	LIB 730	INTERNET LITERACY	0.0	3/11-4/08	SAT	100P-300P	SV002
4245	CSIS 126	WORD PROCESS-MS WRD	2.0	3/13-5/15	M	1010A-200P	BU111
6053	CSIS 1	COMPUTER LITERACY	2.0	3/15-5/17	W	600P-950P	BU110
6148	PE 17	GOLF	0.5	3/18-5/20	SAT	900A-1130A	GY200C
4055	AH 740	TAI CHI ARTHRITIS	0.0	3/20-4/26	M W	200P-300P	GHR1
4617	PE 16	SWIMMING	0.5	3/20-5/24	M W	1230P-145P	GY100P
4619	PE 17	GOLF	0.5	3/20-5/24	M W	945A-1100A	GY200C
4212	CSIS 1	COMPUTER LITERACY	2.0	3/21-5/25	Tu Th	910A-1100A	BU120
6150	PE 61	SWIM FOR FITNESS	0.5	3/21-5/25	Tu Th	500P-615P	GY100P
4626	PE 27	BASKETBALL	0.5	3/21-5/25	Tu Th	210P-400P	GY131G
4645	PE 46	AGILITY/MOTOR DEV	0.5	3/27-5/25	MTuWTh	310P-350P	GY131G
6051	CMUN 129	PRESENTATN GRAPHICS	1.0	4/05-5/10	W	600P-950P	BU111
6073	CSIS 129	PRESENTATN GRAPHICS	1.0	4/05-5/10	W	600P-950P	BU111
6026	BIO 21	FIELD ECOLOGY	1.0	4/24-4/30	M	500P-600P	LS101
					F	500P-800P	
					SAT	800A-500P	
					SUN	800A-300P	
4034	AH 16	IV THERAPY	2.0	6/06-6/15	MTuWTh	900A-330P	HOB114

## Morgan Hill

SECT	COURSE	CLASS	UNITS	DATES
6071	CSIS 128 W	DATABASE-MS ACCESS 600P-950P	2.0 MHG8	2/01-3/29
6050	CMUN 129 SAT	PRESENTATN GRAPHICS 830A-1220P	1.0 MHG5	2/04-3/11
6072	CSIS 129 SAT	PRESENTATN GRAPHICS 830A-1220P	1.0 MHG5	2/04-3/11
4237	CSIS 122 Tu Th	COMPUTER KEYBOARD 1010A-1200P	0.5 MHG8	2/28-5/18
4240	CSIS 122 Tu Th	COMPUTER KEYBOARD 1010A-1200P	1.0 MHG8	2/28-5/18
4536	LIB 730 M W	INTERNET LITERACY 1130A-100P	0.0 MHG5	3/06-4/12
4242	CSIS 124 Tu Th	WINDOWS FUNDAMENTAL 910A-100P	1.0 MHG8	3/09-3/23
6064	CSIS 121 SAT	SPREADSHEET-MS EXCL 830A-1220P	2.0 MHG5	3/18-5/20
6035	CD 11A SAT	ADMIN/PROGRAM CHILD 800A-400P	3.0 MHG4	3/25-5/13
4244	CSIS 126 Tu Th	WORD PROCESS-MS WRD 910A-100P	2.0 MHG8	3/28-5/02
4219	CSIS 8 Tu Th	INTRO TO INTERNET 910A-100P	1.0 MHG8	5/04-5/18

## Hollister

SECT	COURSE	CLASS	UNITS	DATES
4239	CSIS 122 M W	COMPUTER KEYBOARD 1010A-1200P	1.0 HOL3	2/01-5/03
6069	CSIS 124 W	WINDOWS FUNDAMENTAL 600P-950P	1.0 HOL3	2/08-3/08
4539	LIB 730 Tu Th	INTERNET LITERACY 100P-230P	0.0 HOL3	3/07-4/13
6070	CSIS 126 W	WORD PROCESS-MS WRD 600P-950P	2.0 HOL3	3/15-5/17
4241	CSIS 124 M W	WINDOWS FUNDAMENTAL 910A-100P	1.0 HOL3	3/20-4/03
4246	CSIS 126 M W	WORD PROCESS-MS WRD 910A-100P	2.0 HOL3	4/05-5/10

See also: Noncredit classes - pages 108-110.